

CQDD-16M  
CQDD-16N

SURFACE MOUNT  
16 AMP SILICON TRIAC  
600 THRU 800 VOLTS

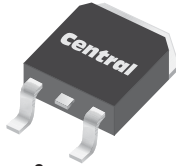

D<sup>2</sup>PAK CASE



www.centrasemi.com

**DESCRIPTION:**

The CENTRAL SEMICONDUCTOR CQDD-16M series type is an Epoxy Molded Silicon Triac designed for full wave AC control applications featuring gate triggering in all four (4) quadrants.

**MARKING: FULL PART NUMBER**

MAXIMUM RATINGS: (T <sub>C</sub> =25°C unless otherwise noted)	SYMBOL	CQDD-16M	CQDD-16N	UNITS
Peak Repetitive Off-State Voltage	V <sub>DRM</sub>	600	800	V
RMS On-State Current (T <sub>C</sub> =90°C)	I <sub>T(RMS)</sub>	16		A
Peak One Cycle Surge, t=8.3ms	I <sub>TSM</sub>	110		A
I <sup>2</sup> t Value for Fusing, t=8.3ms	I <sup>2</sup> t	50		A <sup>2</sup> s
Peak Gate Power, tp=10µs	P <sub>GM</sub>	40		W
Average Gate Power Dissipation	P <sub>G(AV)</sub>	1.0		W
Peak Gate Current, tp=10µs	I <sub>GM</sub>	6.0		A
Peak Gate Voltage, tp=10µs	V <sub>GM</sub>	16		V
Critical Rate of Rise of On-State Current Repetitive, f=60Hz	di/dt	10		A/µs
Operating Junction Temperature	T <sub>J</sub>	-40 to +125		°C
Storage Temperature	T <sub>stg</sub>	-40 to +150		°C
Thermal Resistance	θ <sub>JA</sub>	60		°C/W
Thermal Resistance	θ <sub>JC</sub>	2.3		°C/W

**ELECTRICAL CHARACTERISTICS: (T<sub>C</sub>=25°C unless otherwise noted)**

SYMBOL	TEST CONDITIONS	MIN	TYP	MAX	UNITS
I <sub>DRM</sub>	Rated V <sub>DRM</sub>			10	µA
I <sub>DRM</sub>	Rated V <sub>DRM</sub> , T <sub>C</sub> =125°C			2.0	mA
I <sub>GT</sub>	V <sub>D</sub> =12V, R <sub>L</sub> =10Ω, QUAD I, II, III		10.9	25	mA
I <sub>GT</sub>	V <sub>D</sub> =12V, R <sub>L</sub> =10Ω, QUAD IV		55.2	75	mA
I <sub>H</sub>	I <sub>T</sub> =100mA		9.8	25	mA
V <sub>GT</sub>	V <sub>D</sub> =12V, R <sub>L</sub> =10Ω, QUAD I, II, III		0.97	1.50	V
V <sub>GT</sub>	V <sub>D</sub> =12V, R <sub>L</sub> =10Ω, QUAD IV		1.51	2.50	V
V <sub>TM</sub>	I <sub>TM</sub> =22.5A, tp=380µs		1.35	1.60	V
dv/dt	V <sub>D</sub> =2/3 V <sub>DRM</sub> , R <sub>GK</sub> =∞, T <sub>C</sub> =125°C	10			V/µs

R2 (12-February 2010)

CQDD-16M  
CQDD-16N

SURFACE MOUNT  
16 AMP SILICON TRIAC  
600 THRU 800 VOLTS



D<sup>2</sup>PAK CASE - MECHANICAL OUTLINE

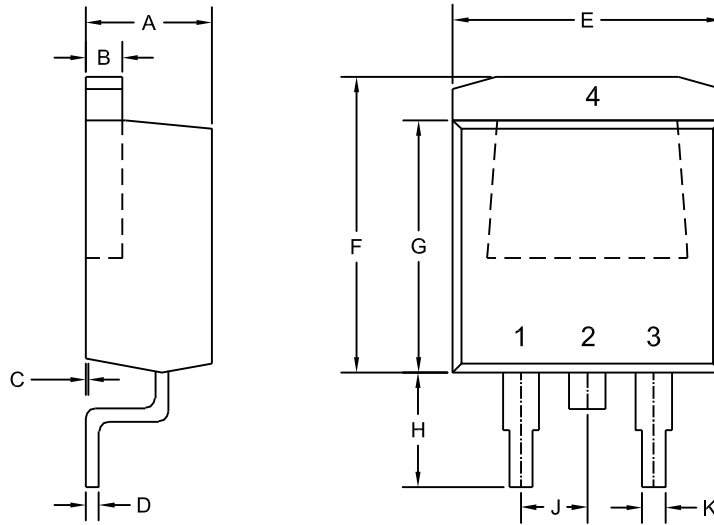

R2

**LEAD CODE:**

- 1) MT1
- 2) MT2
- 3) Gate
- 4) MT2

**MARKING:**

**FULL PART NUMBER**

DIMENSIONS				
SYMBOL	INCHES		MILLIMETERS	
	MIN	MAX	MIN	MAX
A	0.163	0.189	4.14	4.80
B	0.045	0.055	1.14	1.40
C	0.000	0.010	0.00	0.25
D	0.012	0.028	0.30	0.70
E	0.386	0.409	9.80	10.40
F	0.378	0.417	9.60	10.60
G	0.335	0.358	8.50	9.10
H	0.197	0.236	5.00	6.00
J	0.093	0.108	2.35	2.75
K	0.030	0.035	0.75	0.90

D2PAK (REV: R2)

R2 (12-February 2010)