

CMPT3640
SURFACE MOUNT
PNP SILICON TRANSISTOR



www.centrasemi.com

DESCRIPTION:

The CENTRAL SEMICONDUCTOR CMPT3640 type is a PNP silicon transistor manufactured by the epitaxial planar process, epoxy molded in a surface mount package, designed for saturated switching applications.

MARKING CODE: C2J



SOT-23 CASE

MAXIMUM RATINGS: ($T_A=25^\circ\text{C}$)

Collector-Base Voltage
Collector-Emitter Voltage
Emitter-Base Voltage
Continuous Collector Current
Power Dissipation
Operating and Storage Junction Temperature
Thermal Resistance

SYMBOL		UNITS
V_{CB0}	12	V
V_{CEO}	12	V
V_{EBO}	4.0	V
I_C	80	mA
P_D	350	mW
T_J, T_{stg}	-65 to +150	$^\circ\text{C}$
θ_{JA}	357	$^\circ\text{C}/\text{W}$

ELECTRICAL CHARACTERISTICS: ($T_A=25^\circ\text{C}$ unless otherwise noted)

SYMBOL	TEST CONDITIONS	MIN	MAX	UNITS
I_{CES}	$V_{CE}=6.0\text{V}$		10	nA
I_{CES}	$V_{CE}=6.0\text{V}, T_A=65^\circ\text{C}$		10	μA
I_B	$V_{CE}=6.0\text{V}, V_{EB}=0$		10	nA
BV_{CB0}	$I_C=100\mu\text{A}$	12		V
BV_{CEO}	$I_C=10\text{mA}$	12		V
BV_{EBO}	$I_E=100\mu\text{A}$	4.0		V
$V_{CE(SAT)}$	$I_C=10\text{mA}, I_B=1.0\text{mA}$		0.20	V
$V_{CE(SAT)}$	$I_C=50\text{mA}, I_B=5.0\text{mA}$		0.60	V
$V_{CE(SAT)}$	$I_C=10\text{mA}, I_B=1.0\text{mA}, T_A=65^\circ\text{C}$		0.25	V
$V_{BE(SAT)}$	$I_C=10\text{mA}, I_B=0.5\text{mA}$	0.75	0.95	V
$V_{BE(SAT)}$	$I_C=10\text{mA}, I_B=1.0\text{mA}$	0.80	1.00	V
$V_{BE(SAT)}$	$I_C=50\text{mA}, I_B=5.0\text{mA}$		1.50	V
h_{FE}	$V_{CE}=0.3\text{V}, I_C=10\text{mA}$	30	120	
h_{FE}	$V_{CE}=1.0\text{V}, I_C=50\text{mA}$	20		
f_T	$V_{CE}=5.0\text{V}, I_C=10\text{mA}, f=100\text{MHz}$	500		MHz
C_{ob}	$V_{CB}=5.0\text{V}, I_E=0, f=1.0\text{MHz}$		3.5	pF
C_{ib}	$V_{BE}=0.5\text{V}, I_C=0, f=1.0\text{MHz}$		3.5	pF
t_d	$V_{CC}=6.0\text{V}, V_{BE}=1.9, I_C=50\text{mA}, I_{B1}=5.0\text{mA}$		10	ns
t_r	$V_{CC}=6.0\text{V}, V_{BE}=1.9, I_C=50\text{mA}, I_{B1}=5.0\text{mA}$		30	ns

R5 (1-February 2010)

CMPT3640
SURFACE MOUNT
PNP SILICON TRANSISTOR



ELECTRICAL CHARACTERISTICS - Continued: ($T_A=25^{\circ}\text{C}$ unless otherwise noted)

SYMBOL	TEST CONDITIONS	MAX	UNITS
t_s	$V_{CC}=6.0\text{V}$, $I_C=50\text{mA}$, $I_{B1}=I_{B2}=5.0\text{mA}$	20	ns
t_f	$V_{CC}=6.0\text{V}$, $I_C=50\text{mA}$, $I_{B1}=I_{B2}=5.0\text{mA}$	12	ns
t_{on}	$V_{CC}=6.0\text{V}$, $V_{BE}=1.9$, $I_C=50\text{mA}$, $I_{B1}=5.0\text{mA}$	25	ns
t_{on}	$V_{CC}=1.5\text{V}$, $I_C=10\text{mA}$, $I_{B1}=0.5\text{mA}$	60	ns
t_{off}	$V_{CC}=6.0\text{V}$, $V_{BE}=1.9$, $I_C=50\text{mA}$, $I_{B1}=5.0\text{mA}$	35	ns
t_{off}	$V_{CC}=1.5\text{V}$, $I_C=10\text{mA}$, $I_{B1}=I_{B2}=0.5\text{mA}$	75	ns

SOT-23 CASE - MECHANICAL OUTLINE

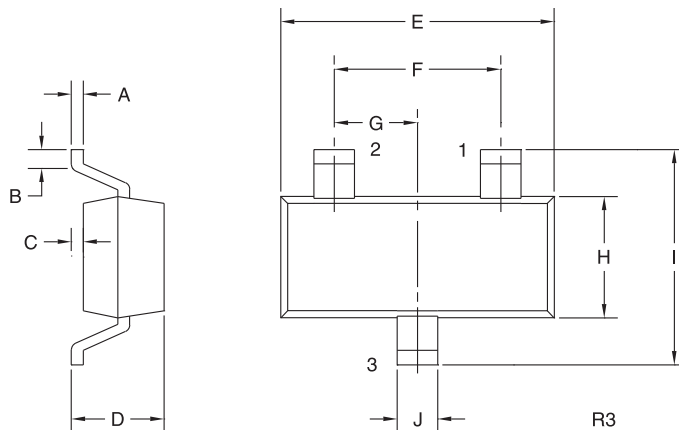

LEAD CODE:

- 1) Base
- 2) Emitter
- 3) Collector

MARKING CODE: C2J

SYMBOL	DIMENSIONS			
	INCHES		MILLIMETERS	
	MIN	MAX	MIN	MAX
A	0.003	0.007	0.08	0.18
B	0.006	-	0.15	-
C	-	0.005	-	0.13
D	0.035	0.043	0.89	1.09
E	0.110	0.120	2.80	3.05
F	0.075		1.90	
G	0.037		0.95	
H	0.047	0.055	1.19	1.40
I	0.083	0.098	2.10	2.49
J	0.014	0.020	0.35	0.50

SOT-23 (REV: R3)

R5 (1-February 2010)