

CMUT3410 NPN
CMUT7410 PNP

**SURFACE MOUNT
COMPLEMENTARY LOW $V_{CE(SAT)}$
SILICON TRANSISTORS**

ULTRAmⁱⁿⁱ

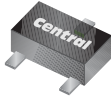

SOT-523 CASE

Central
Semiconductor Corp.

www.centrasemi.com

DESCRIPTION:

The CENTRAL SEMICONDUCTOR CMUT3410, and CMUT7410, are low $V_{CE(SAT)}$ silicon transistors in an ULTRAmⁱⁿⁱ™ surface mount package designed for small signal general purpose amplifier and switching applications, requiring low collector emitter saturation voltage.

**MARKING CODES: CMUT3410: C43
CMUT7410: C47**

MAXIMUM RATINGS: ($T_A=25^\circ\text{C}$)

Collector-Base Voltage
Collector-Emitter Voltage
Emitter-Base Voltage
Continuous Collector Current
Peak Collector Current
Power Dissipation
Operating and Storage Junction Temperature
Thermal Resistance

SYMBOL

V_{CBO} 40
 V_{CEO} 25
 V_{EBO} 6.0
 I_C 1.0
 I_{CM} 1.5
 P_D 250
 T_J, T_{stg} -65 to +150
 θ_{JA} 500

UNITS

V
V
V
A
A
mW
 $^\circ\text{C}$
 $^\circ\text{C/W}$

ELECTRICAL CHARACTERISTICS: ($T_A=25^\circ\text{C}$ unless otherwise noted)

SYMBOL	TEST CONDITIONS	MIN	NPN		MAX	UNITS
			TYP	PNP TYP		
I_{CBO}	$V_{CB}=40\text{V}$				100	nA
I_{EBO}	$V_{EB}=6.0\text{V}$				100	nA
BV_{CBO}	$I_C=100\mu\text{A}$	40				V
BV_{CEO}	$I_C=10\text{mA}$	25				V
BV_{EBO}	$I_E=100\mu\text{A}$	6.0				V
$V_{CE(SAT)}$	$I_C=50\text{mA}, I_B=5.0\text{mA}$		25	30	50	mV
$V_{CE(SAT)}$	$I_C=100\text{mA}, I_B=10\text{mA}$		40	50	75	mV
$V_{CE(SAT)}$	$I_C=200\text{mA}, I_B=20\text{mA}$		80	95	150	mV
$V_{CE(SAT)}$	$I_C=500\text{mA}, I_B=50\text{mA}$		190	205	250	mV
$V_{CE(SAT)}$	$I_C=800\text{mA}, I_B=80\text{mA}$		290	320	400	mV
$V_{CE(SAT)}$	$I_C=1.0\text{A}, I_B=100\text{mA}$		360	400	450	mV
$V_{BE(SAT)}$	$I_C=800\text{mA}, I_B=80\text{mA}$				1.1	V
$V_{BE(ON)}$	$V_{CE}=1.0\text{V}, I_C=10\text{mA}$				0.9	V
h_{FE}	$V_{CE}=1.0\text{V}, I_C=10\text{mA}$	100				
h_{FE}	$V_{CE}=1.0\text{V}, I_C=100\text{mA}$	100			300	
h_{FE}	$V_{CE}=1.0\text{V}, I_C=500\text{mA}$	100				
h_{FE}	$V_{CE}=1.0\text{V}, I_C=1.0\text{A}$	50	125	75		
f_T	$V_{CE}=10\text{V}, I_C=50\text{mA}, f=100\text{MHz}$	100				MHz
C_{ob}	$V_{CB}=10\text{V}, I_E=0, f=1.0\text{MHz}$ (CMUT3410)		6.0		10	pF
C_{ob}	$V_{CB}=10\text{V}, I_E=0, f=1.0\text{MHz}$ (CMUT7410)			10	15	pF

R2 (1-August 2011)

CMUT3410 NPN
 CMUT7410 PNP

SURFACE MOUNT
 COMPLEMENTARY LOW $V_{CE(SAT)}$
 SILICON TRANSISTORS



SOT-523 CASE - MECHANICAL OUTLINE

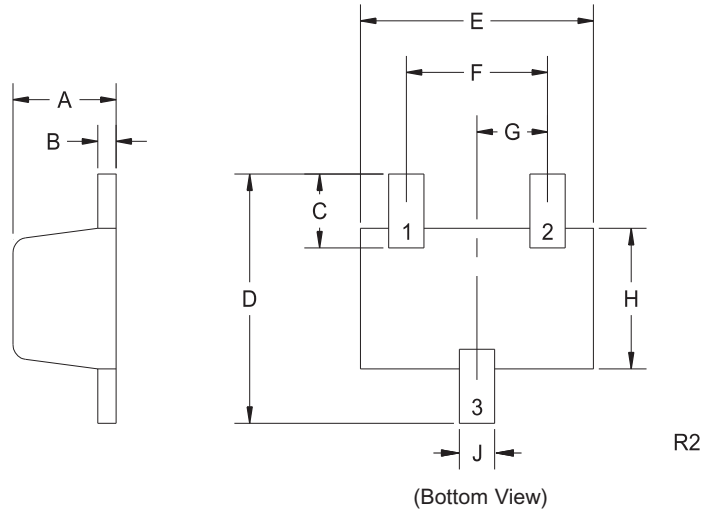

LEAD CODE:

- 1) Base
- 2) Emitter
- 3) Collector

MARKING CODES:

CMUT3410: C43
 CMUT7410: C47

SYMBOL	INCHES		MILLIMETERS	
	MIN	MAX	MIN	MAX
A	0.023	0.031	0.58	0.78
B	0.002	0.008	0.04	0.20
C	0.013	0.021	0.34	0.54
D	0.059	0.067	1.50	1.70
E	0.059	0.067	1.50	1.70
F	0.035	0.043	0.90	1.10
G	0.020		0.50	
H	0.031	0.039	0.78	0.98
J	0.010	0.014	0.25	0.35

SOT-523 (REV: R2)

R2 (1-August 2011)