

CMST5088
CMST5089

SURFACE MOUNT
NPN SILICON TRANSISTOR

SUPERmini™



SOT-323 CASE



www.centrasemi.com

DESCRIPTION:

The CENTRAL SEMICONDUCTOR CMST5088, CMST5089 types are NPN silicon transistors manufactured by the epitaxial planar process, epoxy molded in a SUPERmini™ surface mount package, designed for applications requiring high gain and low noise.

**MARKING CODES: CMST5088: 1QC
CMST5089: 1RC**

MAXIMUM RATINGS: (T_A=25°C)

Collector-Base Voltage
Collector-Emitter Voltage
Emitter-Base Voltage
Continuous Collector Current
Power Dissipation
Operating and Storage Junction Temperature
Thermal Resistance

SYMBOL	CMST5088	CMST5089	UNITS
V _{CBO}	35	30	V
V _{CEO}	30	25	V
V _{EBO}		4.5	V
I _C		50	mA
P _D		275	mW
T _J , T _{stg}		-65 to +150	°C
θ _{JA}		455	°C/W

ELECTRICAL CHARACTERISTICS: (T_A=25°C unless otherwise noted)

SYMBOL	TEST CONDITIONS	CMST5088		CMST5089		UNITS
		MIN	MAX	MIN	MAX	
I _{CBO}	V _{CB} =20V	-	50	-	-	nA
I _{CBO}	V _{CB} =15V	-	-	-	50	nA
I _{EBO}	V _{EB} =3.0V	-	50	-	-	nA
I _{EBO}	V _{EB} =4.5V	-	-	-	100	nA
BV _{CBO}	I _C =100μA	35	-	30	-	V
BV _{CEO}	I _C =1.0mA	30	-	25	-	V
BV _{EBO}	I _E =100μA	4.5	-	4.5	-	V
V _{CE(SAT)}	I _C =10mA, I _B =1.0mA	-	0.5	-	0.5	V
V _{BE(SAT)}	I _C =10mA, I _B =1.0mA	-	0.8	-	0.8	V
h _{FE}	V _{CE} =5.0V, I _C =0.1mA	300	900	400	1200	
h _{FE}	V _{CE} =5.0V, I _C =1.0mA	350	-	450	-	
h _{FE}	V _{CE} =5.0V, I _C =10mA	300	-	400	-	
f _T	V _{CE} =5.0V, I _C =500μA, f=20MHz	50	-	50	-	MHz
C _{ob}	V _{CB} =5.0V, I _E =0, f=1.0MHz	-	4.0	-	4.0	pF
C _{ib}	V _{BE} =0.5V, I _C =0, f=1.0MHz	-	15	-	15	pF
h _{fe}	V _{CE} =5.0V, I _C =1.0mA, f=1.0kHz	350	1400	450	1800	
NF	V _{CE} =5.0V, I _C =100μA, R _S =10kΩ f=10Hz to 15.7kHz	-	3.0	-	2.0	dB

R4 (9-February 2010)

CMST5088
 CMST5089

SURFACE MOUNT
 NPN SILICON TRANSISTOR



SOT-323 CASE - MECHANICAL OUTLINE

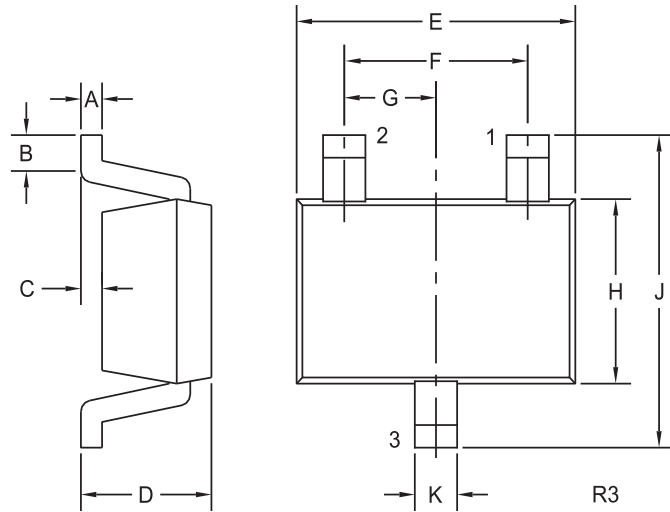

PIN CONFIGURATION

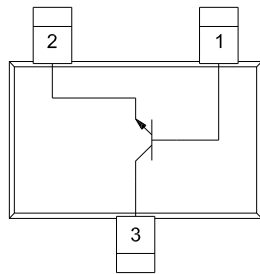

LEAD CODE:

- 1) Base
- 2) Emitter
- 3) Collector

MARKING CODES:

CMST5088: 1QC
 CMST5089: 1RC

SYMBOL	INCHES		MILLIMETERS	
	MIN	MAX	MIN	MAX
A	0.002	0.008	0.05	0.20
B	0.004	-	0.10	-
C	-	0.004	-	0.10
D	0.031	0.043	0.80	1.10
E	0.071	0.087	1.80	2.20
F	0.051		1.30	
G	0.026		0.65	
H	0.045	0.053	1.15	1.35
J	0.079	0.087	2.00	2.20
K	0.008	0.016	0.20	0.40

SOT-323 (REV: R3)

R4 (9-February 2010)