

CMPT6428
CMPT6429

**SURFACE MOUNT
NPN SILICON TRANSISTOR**

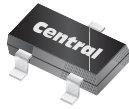

SOT-23 CASE



www.centrasemi.com

DESCRIPTION:

The CENTRAL SEMICONDUCTOR CMPT6428 and CMPT6429 are NPN Silicon Transistors manufactured by the epitaxial planar process, epoxy molded in a surface mount package, designed for high gain amplifier applications.

**MARKING CODES: CMPT6428: C1K
CMPT6429: C1L**

MAXIMUM RATINGS: ($T_A=25^\circ\text{C}$)

Collector-Base Voltage
Collector-Emitter Voltage
Emitter-Base Voltage
Continuous Collector Current
Power Dissipation
Operating and Storage Junction Temperature
Thermal Resistance

SYMBOL	CMPT6428	CMPT6429	UNITS
V_{CBO}	60	55	V
V_{CEO}	50	45	V
V_{EBO}		6.0	V
I_C		200	mA
P_D		350	mW
T_J, T_{stg}		-65 to +150	$^\circ\text{C}$
θ_{JA}		357	$^\circ\text{C/W}$

ELECTRICAL CHARACTERISTICS: ($T_A=25^\circ\text{C}$ unless otherwise noted)

SYMBOL	TEST CONDITIONS	CMPT6428		CMPT6429		UNITS
		MIN	MAX	MIN	MAX	
I_{CBO}	$V_{CB}=30\text{V}$	-	10	-	10	nA
I_{CEO}	$V_{CE}=30\text{V}$	-	100	-	100	nA
I_{EBO}	$V_{BE}=5.0\text{V}$	-	10	-	10	nA
BV_{CBO}	$I_C=100\mu\text{A}$	60	-	55	-	V
BV_{CEO}	$I_C=1.0\text{mA}$	50	-	45	-	V
$V_{CE(SAT)}$	$I_C=10\text{mA}, I_B=0.5\text{mA}$	-	0.20	-	0.20	V
$V_{CE(SAT)}$	$I_C=100\text{mA}, I_B=5.0\text{mA}$	-	0.60	-	0.60	V
$V_{BE(ON)}$	$V_{CE}=5.0\text{V}, I_C=1.0\text{mA}$	0.56	0.66	0.56	0.66	V
h_{FE}	$V_{CE}=5.0\text{V}, I_C=10\mu\text{A}$	250	-	500	-	
h_{FE}	$V_{CE}=5.0\text{V}, I_C=100\mu\text{A}$	250	650	500	1250	
h_{FE}	$V_{CE}=5.0\text{V}, I_C=1.0\text{mA}$	250	-	500	-	
h_{FE}	$V_{CE}=5.0\text{V}, I_C=10\text{mA}$	250	-	500	-	
f_T	$V_{CE}=5.0\text{V}, I_C=1.0\text{mA}, f=100\text{MHz}$	100	700	100	700	MHz
C_{ob}	$V_{CB}=10\text{V}, I_E=0, f=1.0\text{MHz}$	-	3.0	-	3.0	pF
C_{ib}	$V_{BE}=0.5\text{V}, I_C=0, f=1.0\text{MHz}$	-	8.0	-	8.0	pF

R5 (1-February 2010)

CMPT6428
 CMPT6429
 SURFACE MOUNT
 NPN SILICON TRANSISTOR



SOT-23 CASE - MECHANICAL OUTLINE

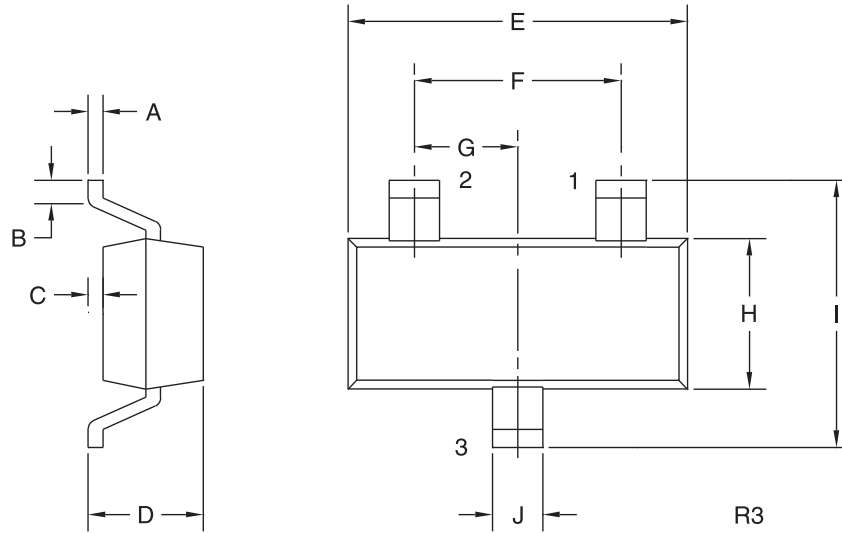

LEAD CODE:

- 1) Base
- 2) Emitter
- 3) Collector

MARKING CODES:

CMPT6428: C1K
 CMPT6429: C1L

DIMENSIONS				
SYMBOL	INCHES		MILLIMETERS	
	MIN	MAX	MIN	MAX
A	0.003	0.007	0.08	0.18
B	0.006	-	0.15	-
C	-	0.005	-	0.13
D	0.035	0.043	0.89	1.09
E	0.110	0.120	2.80	3.05
F	0.075		1.90	
G	0.037		0.95	
H	0.047	0.055	1.19	1.40
I	0.083	0.098	2.10	2.49
J	0.014	0.020	0.35	0.50

SOT-23 (REV: R3)

R5 (1-February 2010)