

CMPT6517 NPN  
CMPT6520 PNP

**SURFACE MOUNT  
COMPLEMENTARY HIGH VOLTAGE  
SILICON TRANSISTORS**



**SOT-23 CASE**



[www.centralemi.com](http://www.centralemi.com)

**DESCRIPTION:**

The CENTRAL SEMICONDUCTOR CMPT6517 and CMPT6520 are complementary silicon transistors manufactured by the epitaxial planar process, epoxy molded in a surface mount package, designed for high voltage driver and amplifier applications.

**MARKING CODES: CMPT6517: C1Z  
CMPT6520: C2Z**

**MAXIMUM RATINGS:** ( $T_A=25^\circ\text{C}$ )

Collector-Base Voltage  
Collector-Emitter Voltage  
Emitter-Base Voltage  
Continuous Collector Current  
Continuous Base Current  
Power Dissipation  
Operating and Storage Junction Temperature  
Thermal Resistance

**SYMBOL**

$V_{CBO}$  350  
 $V_{CEO}$  350  
 $V_{EBO}$  5.0  
 $I_C$  500  
 $I_B$  250  
 $P_D$  350  
 $T_J, T_{stg}$  -65 to +150  
 $\theta_{JA}$  357

**UNITS**

V  
V  
V  
mA  
mA  
mW  
 $^\circ\text{C}$   
 $^\circ\text{C/W}$

**ELECTRICAL CHARACTERISTICS:** ( $T_A=25^\circ\text{C}$  unless otherwise noted)

SYMBOL	TEST CONDITIONS	MIN	MAX	UNITS
$I_{CBO}$	$V_{CB}=250\text{V}$		50	nA
$I_{EBO}$	$V_{EB}=5.0\text{V}$ (CMPT6517)		50	nA
$I_{EBO}$	$V_{EB}=4.0\text{V}$ (CMPT6520)		50	nA
$BV_{CBO}$	$I_C=100\mu\text{A}$	350		V
$BV_{CEO}$	$I_C=1.0\text{mA}$	350		V
$BV_{EBO}$	$I_E=10\mu\text{A}$ (CMPT6517)	6.0		V
$BV_{EBO}$	$I_E=10\mu\text{A}$ (CMPT6520)	5.0		V
$V_{CE(SAT)}$	$I_C=10\text{mA}, I_B=1.0\text{mA}$		0.30	V
$V_{CE(SAT)}$	$I_C=20\text{mA}, I_B=2.0\text{mA}$		0.35	V
$V_{CE(SAT)}$	$I_C=30\text{mA}, I_B=3.0\text{mA}$		0.50	V
$V_{CE(SAT)}$	$I_C=50\text{mA}, I_B=5.0\text{mA}$		1.0	V
$V_{BE(SAT)}$	$I_C=10\text{mA}, I_B=1.0\text{mA}$		0.75	V
$V_{BE(SAT)}$	$I_C=20\text{mA}, I_B=2.0\text{mA}$		0.85	V
$V_{BE(SAT)}$	$I_C=30\text{mA}, I_B=3.0\text{mA}$		0.90	V
$V_{BE(ON)}$	$I_C=10\text{V}, I_C=100\text{mA}$		2.0	V
$h_{FE}$	$V_{CE}=10\text{V}, I_C=1.0\text{mA}$	20		
$h_{FE}$	$V_{CE}=10\text{V}, I_C=10\text{mA}$	30		

R5 (1-February 2010)

CMPT6517 NPN  
CMPT6520 PNP



**SURFACE MOUNT  
COMPLEMENTARY HIGH VOLTAGE  
SILICON TRANSISTORS**

**ELECTRICAL CHARACTERISTICS - Continued:** ( $T_A=25^\circ\text{C}$  unless otherwise noted)

SYMBOL	TEST CONDITIONS	MIN	MAX	UNITS
$h_{FE}$	$V_{CE}=10\text{V}, I_C=30\text{mA}$	30	200	
$h_{FE}$	$V_{CE}=10\text{V}, I_C=50\text{mA}$	20	200	
$h_{FE}$	$V_{CE}=10\text{V}, I_C=100\text{mA}$	15		
$f_T$	$V_{CE}=20\text{V}, I_C=10\text{mA}, f=20\text{MHz}$	40	200	MHz
$C_{cb}$	$V_{CE}=20\text{V}, I_C=0, f=1.0\text{MHz}$		6.0	pF
$C_{eb}$	$V_{EB}=0.5\text{V}, I_E=0, f=1.0\text{MHz}$ (CMPT6517)		80	pF
$C_{eb}$	$V_{EB}=0.5\text{V}, I_E=0, f=1.0\text{MHz}$ (CMPT6520)		100	pF

**SOT-23 CASE - MECHANICAL OUTLINE**

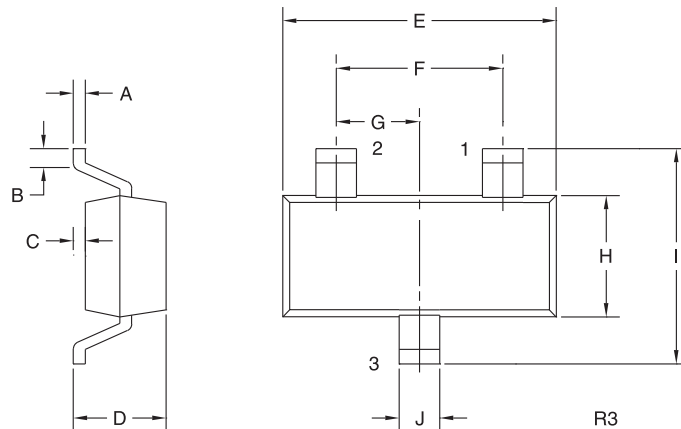

**LEAD CODE:**

- 1) Base
- 2) Emitter
- 3) Collector

**MARKING CODES:**

CMPT6517: C1Z  
CMPT6520: C2Z

SYMBOL	INCHES		MILLIMETERS	
	MIN	MAX	MIN	MAX
A	0.003	0.007	0.08	0.18
B	0.006	-	0.15	-
C	-	0.005	-	0.13
D	0.035	0.043	0.89	1.09
E	0.110	0.120	2.80	3.05
F	0.075		1.90	
G	0.037		0.95	
H	0.047	0.055	1.19	1.40
I	0.083	0.098	2.10	2.49
J	0.014	0.020	0.35	0.50

SOT-23 (REV: R3)

R5 (1-February 2010)