

CMUT4401 NPN
CMUT4403 PNP

**SURFACE MOUNT
COMPLEMENTARY
SILICON TRANSISTORS**

ULTRAmi™

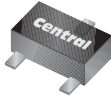

SOT-523 CASE



www.centralemi.com

DESCRIPTION:

The CENTRAL SEMICONDUCTOR CMUT4401 and CMUT4403 are complementary silicon transistors manufactured by the epitaxial planar process, epoxy molded in a ULTRAmi™ surface mount package, designed for small signal general purpose amplifier and switching applications.

**MARKING CODE: CMUT4401: PC1
CMUT4403: FC2**

MAXIMUM RATINGS: (T_A=25°C)

Collector-Base Voltage
Collector-Emitter Voltage
Emitter-Base Voltage
Continuous Collector Current
Power Dissipation
Operating and Storage Junction Temperature
Thermal Resistance

SYMBOL	CMUT4401	CMUT4403	UNITS
V _{CBO}	60	40	V
V _{CEO}	40	40	V
V _{EBO}	6.0	5.0	V
I _C		600	mA
P _D		250	mW
T _J , T _{stg}		-65 to +150	°C
θ _{JA}		500	°C/W

ELECTRICAL CHARACTERISTICS: (T_A=25°C)

SYMBOL	TEST CONDITIONS	CMUT4401		CMUT4403		UNITS
		MIN	MAX	MIN	MAX	
I _{CEV}	V _{CE} =35V, V _{EB} =0.4V	-	0.1	-	0.1	μA
I _{BEV}	V _{CE} =35V, V _{EB} =0.4V	-	0.1	-	0.1	μA
BV _{CBO}	I _C =100μA	60	-	40	-	V
BV _{CEO}	I _C =1.0mA	40	-	40	-	V
BV _{EBO}	I _E =100μA	6.0	-	5.0	-	V
V _{CE(SAT)}	I _C =150mA, I _B =15mA	-	0.40	-	0.40	V
V _{CE(SAT)}	I _C =500mA, I _B =50mA	-	0.75	-	0.75	V
V _{BE(SAT)}	I _C =150mA, I _B =15mA	0.75	0.95	0.75	0.95	V
V _{BE(SAT)}	I _C =500mA, I _B =50mA	-	1.2	-	1.3	V
h _{FE}	V _{CE} =1.0V, I _C =0.1mA	20	-	30	-	
h _{FE}	V _{CE} =1.0V, I _C =1.0mA	40	-	60	-	
h _{FE}	V _{CE} =1.0V, I _C =10mA	80	-	100	-	
h _{FE}	V _{CE} =1.0V, I _C =150mA	100	300	-	-	
h _{FE}	V _{CE} =2.0V, I _C =150mA	-	-	100	300	
h _{FE}	V _{CE} =2.0V, I _C =500mA	40	-	20	-	
f _T	V _{CE} =10V, I _C =20mA, f=100MHz	250	-	200	-	MHz
C _{ob}	V _{CB} =5.0V, I _E =0, f=1.0MHz	-	6.5	-	8.5	pF
C _{ib}	V _{BE} =0.5V, I _C =0, f=1.0MHz	-	30	-	30	pF

R1 (9-February 2010)

CMUT4401 NPN
 CMUT4403 PNP

SURFACE MOUNT
 COMPLEMENTARY
 SILICON TRANSISTORS



ELECTRICAL CHARACTERISTICS - Continued: ($T_A=25^\circ\text{C}$)

SYMBOL	TEST CONDITIONS	CMUT4401		CMUT4403		UNITS
		MIN	MAX	MIN	MAX	
h_{ie}	$V_{CE}=10\text{V}, I_C=1.0\text{mA}, f=1.0\text{kHz}$	1.0	15	1.5	15	$k\Omega$
h_{re}	$V_{CE}=10\text{V}, I_C=1.0\text{mA}, f=1.0\text{kHz}$	0.1	8.0	0.1	8.0	$\times 10^{-4}$
h_{fe}	$V_{CE}=10\text{V}, I_C=1.0\text{mA}, f=1.0\text{kHz}$	40	500	60	500	
h_{oe}	$V_{CE}=10\text{V}, I_C=1.0\text{mA}, f=1.0\text{kHz}$	1.0	30	1.0	100	μS
t_d	$V_{CC}=30\text{V}, V_{BE}=2.0\text{V}, I_C=150\text{mA}, I_{B1}=15\text{mA}$	-	15	-	15	ns
t_r	$V_{CC}=30\text{V}, V_{BE}=2.0\text{V}, I_C=150\text{mA}, I_{B1}=15\text{mA}$	-	20	-	20	ns
t_s	$V_{CC}=30\text{V}, I_C=150\text{mA}, I_{B1}=I_{B2}=15\text{mA}$	-	225	-	225	ns
t_f	$V_{CC}=30\text{V}, I_C=150\text{mA}, I_{B1}=I_{B2}=15\text{mA}$	-	30	-	30	ns

SOT-523 CASE - MECHANICAL OUTLINE

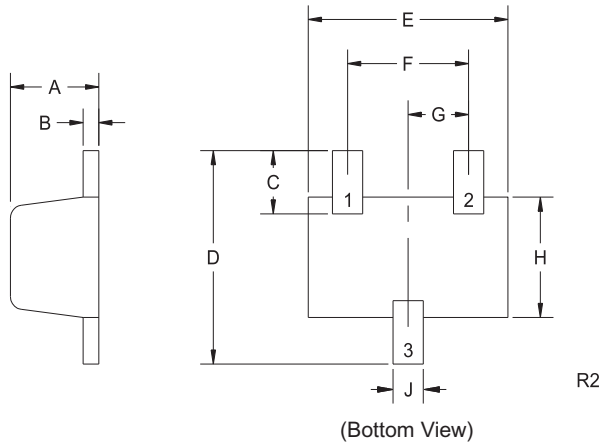

SYMBOL	DIMENSIONS			
	INCHES		MILLIMETERS	
	MIN	MAX	MIN	MAX
A	0.023	0.031	0.58	0.78
B	0.002	0.008	0.04	0.20
C	0.013	0.021	0.34	0.54
D	0.059	0.067	1.50	1.70
E	0.059	0.067	1.50	1.70
F	0.035	0.043	0.90	1.10
G	0.020		0.50	
H	0.031	0.039	0.78	0.98
J	0.010	0.014	0.25	0.35

SOT-523 (REV: R2)

LEAD CODE:

- 1) Base
- 2) Emitter
- 3) Collector

MARKING CODES:

CMUT4401: PC1
 CMUT4403: FC2

R1 (9-February 2010)