

CMUT3904 NPN
CMUT3906 PNP

**SURFACE MOUNT
COMPLEMENTARY
SILICON TRANSISTORS**

ULTRAmimi™

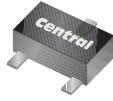

SOT-523 CASE

Central™
Semiconductor Corp.

www.centrasemi.com

DESCRIPTION:

The CENTRAL SEMICONDUCTOR CMUT3904, CMUT3906 types are complementary silicon transistors manufactured by the epitaxial planar process, epoxy molded in an ULTRAmimi™ surface mount package, designed for small signal general purpose amplifier and switching applications.

**MARKING CODES: CMUT3904: AC1
CMUT3906: AC2**

MAXIMUM RATINGS: ($T_A=25^\circ\text{C}$)

Collector-Base Voltage
Collector-Emitter Voltage
Emitter-Base Voltage
Continuous Collector Current
Power Dissipation
Operating and Storage Junction Temperature
Thermal Resistance

SYMBOL	CMUT3904	CMUT3906	UNITS
V_{CBO}	60	40	V
V_{CEO}	40	40	V
V_{EBO}	6.0	5.0	V
I_C		200	mA
P_D		250	mW
T_J, T_{stg}		-65 to +150	$^\circ\text{C}$
θ_{JA}		500	$^\circ\text{C/W}$

ELECTRICAL CHARACTERISTICS: ($T_A=25^\circ\text{C}$ unless otherwise noted)

SYMBOL	TEST CONDITIONS	CMUT3904		CMUT3906		UNITS
		MIN	MAX	MIN	MAX	
I_{CEV}	$V_{CE}=30\text{V}, V_{EB}=3.0\text{V}$	-	50	-	50	nA
BV_{CBO}	$I_C=10\mu\text{A}$	60	-	40	-	V
BV_{CEO}	$I_C=1.0\text{mA}$	40	-	40	-	V
BV_{EBO}	$I_E=10\mu\text{A}$	6.0	-	5.0	-	V
$V_{CE(SAT)}$	$I_C=10\text{mA}, I_B=1.0\text{mA}$	-	0.20	-	0.25	V
$V_{CE(SAT)}$	$I_C=50\text{mA}, I_B=5.0\text{mA}$	-	0.30	-	0.40	V
$V_{BE(SAT)}$	$I_C=10\text{mA}, I_B=1.0\text{mA}$	0.65	0.85	0.65	0.85	V
$V_{BE(SAT)}$	$I_C=50\text{mA}, I_B=5.0\text{mA}$	-	0.95	-	0.95	V
h_{FE}	$V_{CE}=1.0\text{V}, I_C=0.1\text{mA}$	40	-	-	60	
h_{FE}	$V_{CE}=1.0\text{V}, I_C=1.0\text{mA}$	70	-	-	80	
h_{FE}	$V_{CE}=1.0\text{V}, I_C=10\text{mA}$	100	300	100	300	
h_{FE}	$V_{CE}=1.0\text{V}, I_C=50\text{mA}$	60	-	60	-	
h_{FE}	$V_{CE}=1.0\text{V}, I_C=100\text{mA}$	30	-	30	-	

**CMUT3904 NPN
CMUT3906 PNP**

**SURFACE MOUNT
COMPLEMENTARY
SILICON TRANSISTORS**



ELECTRICAL CHARACTERISTICS - Continued: ($T_A=25^\circ\text{C}$ unless otherwise noted)

SYMBOL	TEST CONDITIONS	CMUT3904		CMUT3906		UNITS
		MIN	MAX	MIN	MAX	
f_T	$V_{CE}=20\text{V}$, $I_C=10\text{mA}$, $f=100\text{MHz}$	300	-	250	-	MHz
C_{ob}	$V_{CB}=5.0\text{V}$, $I_E=0$, $f=1.0\text{MHz}$	-	4.0	-	4.5	pF
C_{ib}	$V_{BE}=0.5\text{V}$, $I_C=0$, $f=1.0\text{MHz}$	-	8.0	-	10	pF
h_{ie}	$V_{CE}=10\text{V}$, $I_C=1.0\text{mA}$, $f=1.0\text{kHz}$	1.0	10	2.0	12	$k\Omega$
h_{re}	$V_{CE}=10\text{V}$, $I_C=1.0\text{mA}$, $f=1.0\text{kHz}$	0.5	8.0	0.1	10	$\times 10^{-4}$
h_{fe}	$V_{CE}=10\text{V}$, $I_C=1.0\text{mA}$, $f=1.0\text{kHz}$	100	400	100	400	
h_{oe}	$V_{CE}=10\text{V}$, $I_C=1.0\text{mA}$, $f=1.0\text{kHz}$	1.0	40	3.0	60	μS
NF	$V_{CE}=5.0\text{V}$, $I_C=100\mu\text{A}$, $R_S=1.0k\Omega$ $f=10\text{Hz}$ to 15.7kHz	-	5.0	-	4.0	dB
t_d	$V_{CC}=3.0\text{V}$, $V_{BE}=0.5\text{V}$, $I_C=10\text{mA}$, $I_{B1}=1.0\text{mA}$	-	35	-	35	ns
t_r	$V_{CC}=3.0\text{V}$, $V_{BE}=0.5\text{V}$, $I_C=10\text{mA}$, $I_{B1}=1.0\text{mA}$	-	35	-	35	ns
t_s	$V_{CC}=3.0\text{V}$, $I_C=10\text{mA}$, $I_{B1}=I_{B2}=1.0\text{mA}$	200	-	225	-	ns
t_f	$V_{CC}=3.0\text{V}$, $I_C=10\text{mA}$, $I_{B1}=I_{B2}=1.0\text{mA}$	50	-	75	-	ns

SOT-523 CASE - MECHANICAL OUTLINE

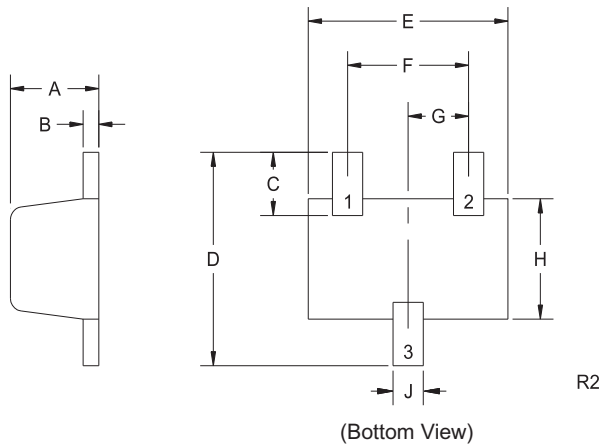

SYMBOL	DIMENSIONS			
	INCHES		MILLIMETERS	
	MIN	MAX	MIN	MAX
A	0.023	0.031	0.58	0.78
B	0.002	0.008	0.04	0.20
C	0.013	0.021	0.34	0.54
D	0.059	0.067	1.50	1.70
E	0.059	0.067	1.50	1.70
F	0.035	0.043	0.90	1.10
G	0.020		0.50	
H	0.031	0.039	0.78	0.98
J	0.010	0.014	0.25	0.35

SOT-523 (REV: R2)

LEAD CODE:

- 1) Base
- 2) Emitter
- 3) Collector

MARKING CODES:

CMUT3904: AC1
CMUT3906: AC2

R2 (9-February 2010)