

CMPT8099 NPN
CMPT8599 PNP

**SURFACE MOUNT
COMPLEMENTARY
SILICON TRANSISTORS**



SOT-23 CASE



www.centrasemi.com

DESCRIPTION:

The CENTRAL SEMICONDUCTOR CMPT8099 and CMPT8599 are complementary silicon transistors manufactured by the epitaxial planar process, epoxy molded in a surface mount package, designed for general purpose audio amplifier applications.

**MARKING CODES: CMPT8099: CKB
CMPT8599: C2W**

MAXIMUM RATINGS: ($T_A=25^\circ\text{C}$)

Collector-Base Voltage	V_{CB0}	80	V
Collector-Emitter Voltage	V_{CEO}	80	V
Emitter-Base Voltage	V_{EBO}	6.0	V
Continuous Collector Current	I_C	500	mA
Power Dissipation	P_D	350	mW
Operating and Storage Junction Temperature	T_J, T_{stg}	-65 to +150	$^\circ\text{C}$
Thermal Resistance	θ_{JA}	357	$^\circ\text{C/W}$

SYMBOL	CMPT8099	CMPT8599	UNITS
V_{CB0}	80	80	V
V_{CEO}	80	80	V
V_{EBO}	6.0	5.0	V
I_C		500	mA
P_D		350	mW
T_J, T_{stg}		-65 to +150	$^\circ\text{C}$
θ_{JA}		357	$^\circ\text{C/W}$

ELECTRICAL CHARACTERISTICS: ($T_A=25^\circ\text{C}$ unless otherwise noted)

SYMBOL	TEST CONDITIONS	CMPT8099		CMPT8599		UNITS
		MIN	MAX	MIN	MAX	
I_{CBO}	$V_{CB}=80\text{V}$		0.1		0.1	μA
I_{EBO}	$V_{BE}=6.0\text{V}$		0.1		-	μA
I_{EBO}	$V_{BE}=4.0\text{V}$		-		0.1	μA
BV_{CB0}	$I_C=100\mu\text{A}$	80		80		V
BV_{CEO}	$I_C=10\text{mA}$	80		80		V
BV_{EBO}	$I_E=10\mu\text{A}$	6.0		5.0		V
$V_{CE(SAT)}$	$I_C=100\text{mA}, I_B=5.0\text{mA}$		0.4		0.4	V
$V_{CE(SAT)}$	$I_C=100\text{mA}, I_B=10\text{mA}$		0.3		0.3	V
$V_{BE(ON)}$	$V_{CE}=5.0\text{V}, I_C=10\text{mA}$	0.6	0.8	0.6	0.8	V
h_{FE}	$V_{CE}=5.0\text{V}, I_C=1.0\text{mA}$	100	300	100	300	
h_{FE}	$V_{CE}=5.0\text{V}, I_C=10\text{mA}$	100		100		
h_{FE}	$V_{CE}=5.0\text{V}, I_C=100\text{mA}$	75		75		
f_T	$V_{CE}=5.0\text{V}, I_C=10\text{mA}, f=100\text{MHz}$	150		150		MHz
C_{ob}	$V_{CB}=10\text{V}, I_E=0, f=1.0\text{MHz}$		6.0		4.5	pF
C_{ib}	$V_{BE}=0.5\text{V}, I_C=0, f=1.0\text{MHz}$		25		30	pF

R5 (1-February 2010)

CMPT8099 NPN
 CMPT8599 PNP

**SURFACE MOUNT
 COMPLEMENTARY
 SILICON TRANSISTORS**



SOT-23 CASE - MECHANICAL OUTLINE

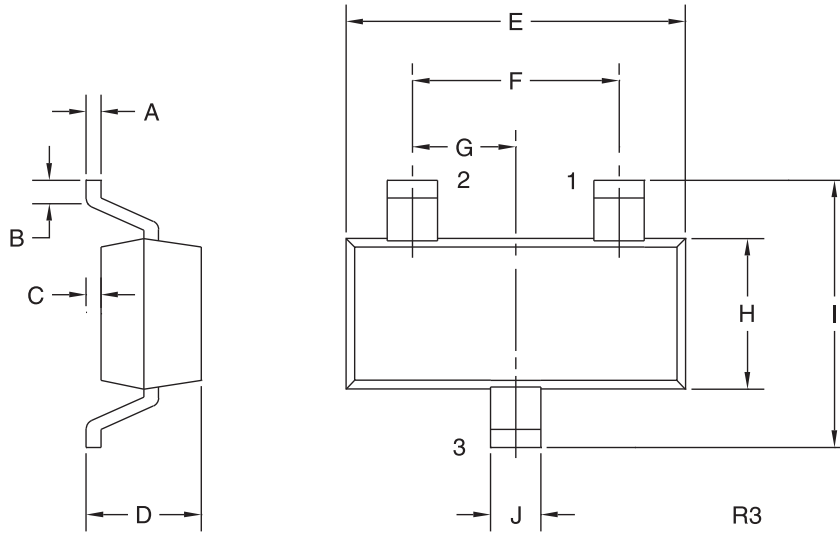

LEAD CODE:

- 1) Base
- 2) Emitter
- 3) Collector

MARKING CODES:

CMPT8099: CKB
 CMPT8599: C2W

DIMENSIONS				
SYMBOL	INCHES		MILLIMETERS	
	MIN	MAX	MIN	MAX
A	0.003	0.007	0.08	0.18
B	0.006	-	0.15	-
C	-	0.005	-	0.13
D	0.035	0.043	0.89	1.09
E	0.110	0.120	2.80	3.05
F	0.075		1.90	
G	0.037		0.95	
H	0.047	0.055	1.19	1.40
I	0.083	0.098	2.10	2.49
J	0.014	0.020	0.35	0.50

SOT-23 (REV: R3)

R5 (1-February 2010)