

**BC846T SERIES
BC847T SERIES**

**SURFACE MOUNT
NPN SILICON TRANSISTOR**

ULTRAmi™

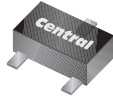

SOT-523 CASE



www.centrasemi.com

DESCRIPTION:

The CENTRAL SEMICONDUCTOR BC846T and BC847T Series types are NPN Silicon Transistors manufactured by the epitaxial planar process, epoxy molded in a surface mount package, designed for general purpose switching and amplifier applications.

MARKING CODE: SEE MARKING CODE TABLE ON FOLLOWING PAGE

MAXIMUM RATINGS: ($T_A=25^\circ\text{C}$)

Collector-Base Voltage
Collector-Emitter Voltage
Emitter-Base Voltage
Continuous Collector Current
Peak Collector Current
Peak Base Current
Power Dissipation
Operating and Storage Junction Temperature
Thermal Resistance

SYMBOL	BC847T	BC846T	UNITS
V_{CB0}	50	80	V
V_{CEO}	45	65	V
V_{EBO}		5.0	V
I_C		100	mA
I_{CM}		200	mA
I_{BM}		100	mA
P_D		250	mW
T_J, T_{stg}	-65 to +150		$^\circ\text{C}$
θ_{JA}	500		$^\circ\text{C/W}$

ELECTRICAL CHARACTERISTICS: ($T_A=25^\circ\text{C}$ unless otherwise noted)

SYMBOL	TEST CONDITIONS	MIN	TYP	MAX	UNITS
I_{CBO}	$V_{CB}=30\text{V}$			15	nA
I_{CBO}	$V_{CB}=30\text{V}, T_A=150^\circ\text{C}$			5.0	μA
I_{EBO}	$V_{EB}=5.0\text{V}$			100	nA
BV_{CBO}	$I_C=10\mu\text{A}$ (BC847T)	50			V
BV_{CBO}	$I_C=10\mu\text{A}$ (BC846T)	80			V
BV_{CEO}	$I_C=10\text{mA}$ (BC847T)	45			V
BV_{CEO}	$I_C=10\text{mA}$ (BC846T)	65			V
BV_{EBO}	$I_E=10\mu\text{A}$	5.0			V
$V_{CE(SAT)}$	$I_C=10\text{mA}, I_B=0.5\text{mA}$			0.20	V
$V_{CE(SAT)}$	$I_C=100\text{mA}, I_B=5.0\text{mA}$			0.40	V
$V_{BE(ON)}$	$I_C=2.0\text{mA}, V_{CE}=5.0\text{V}$	0.58		0.70	V
$V_{BE(ON)}$	$I_C=10\text{mA}, V_{CE}=5.0\text{V}$			0.77	V
f_T	$V_{CE}=5.0\text{V}, I_C=10\text{mA}, f=100\text{MHz}$	100			MHz
C_c	$V_{CB}=10\text{V}, I_E=0, f=1.0\text{MHz}$			1.5	pF
C_e	$V_{EB}=0.5\text{V}, I_C=0, f=1.0\text{MHz}$		11		pF
NF	$V_{CE}=5.0\text{V}, I_C=200\mu\text{A}, R_S=2.0\text{K}\Omega, f=1.0\text{KHz}, BW=200\text{Hz}$			10	dB

		BC846AT		BC846BT		BC847CT	
		MIN	MAX	MIN	MAX	MIN	MAX
h_{FE}	$V_{CE}=5.0\text{V}, I_C=2.0\text{mA}$	110	220	200	450	420	800

R1 (20-November 2009)

BC846T SERIES
BC847T SERIES

SURFACE MOUNT
NPN SILICON TRANSISTOR



SOT-523 CASE - MECHANICAL OUTLINE

BOTTOM VIEW

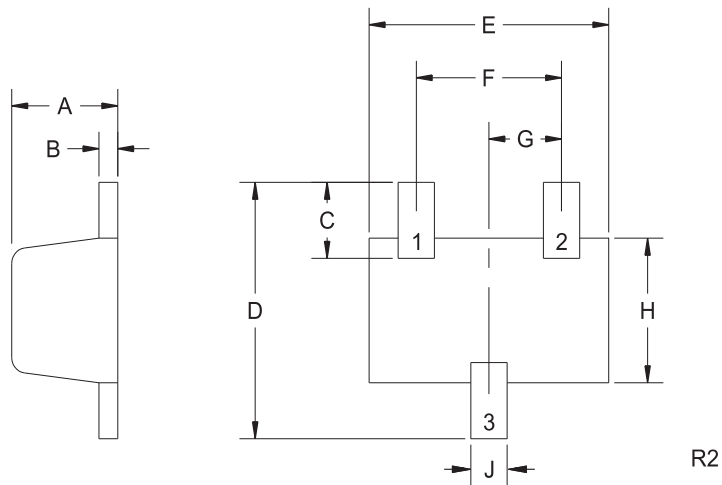

LEAD CODE:

- 1) BASE
- 2) EMITTER
- 3) COLLECTOR

DEVICE	MARKING CODE
BC846AT	GT1
BC846BT	GT2
BC847AT	GT3
BC847BT	GT4
BC847CT	GT5

SYMBOL	DIMENSIONS		DIMENSIONS	
	INCHES		MILLIMETERS	
	MIN	MAX	MIN	MAX
A	0.023	0.031	0.58	0.78
B	0.002	0.008	0.04	0.20
C	0.013	0.021	0.34	0.54
D	0.059	0.067	1.50	1.70
E	0.059	0.067	1.50	1.70
F	0.035	0.043	0.90	1.10
G	0.020		0.50	
H	0.031	0.039	0.78	0.98
J	0.010	0.014	0.25	0.35

SOT-523 (REV: R2)

R1 (20-November 2009)