

CZT3120

**SURFACE MOUNT
NPN SILICON SWITCHING
POWER TRANSISTOR**

**POWER
223™**



SOT-223 CASE

Central™
Semiconductor Corp.

www.centrasemi.com

DESCRIPTION:

The CENTRAL SEMICONDUCTOR CZT3120 NPN Switching Power Transistor, manufactured by the epitaxial planar process, combines both power and high speed switching characteristics in a SOT-223 Surface Mount Package. Typical applications include drivers, DC-DC converters, and general fast switching applications.

MARKING: FULL PART NUMBER

MAXIMUM RATINGS: ($T_A=25^\circ\text{C}$)

Collector-Base Voltage
Collector-Emitter Voltage
Emitter-Base Voltage
Continuous Collector Current
Power Dissipation
Operating and Storage Junction Temperature
Thermal Resistance

SYMBOL		UNITS
V_{CBO}	120	V
V_{CEO}	70	V
V_{EBO}	7.0	V
I_C	3.0	A
P_D	2.0	W
T_J, T_{stg}	-65 to +150	$^\circ\text{C}$
Θ_{JA}	62.5	$^\circ\text{C/W}$

ELECTRICAL CHARACTERISTICS: ($T_A=25^\circ\text{C}$)

SYMBOL	TEST CONDITIONS	MIN	TYP	MAX	UNITS
I_{CBO}	$V_{CB}=80\text{V}$			1.0	μA
I_{EBO}	$V_{EB}=5.0\text{V}$			1.0	μA
BV_{CBO}	$I_C=50\mu\text{A}$	120	160		V
BV_{CEO}	$I_C=10\text{mA}$	70	90		V
BV_{EBO}	$I_E=50\mu\text{A}$	7.0	15		V
$V_{CE(SAT)}$	$I_C=2.0\text{A}, I_B=200\text{mA}$		250	500	mV
$V_{BE(ON)}$	$I_C=2.0\text{A}, V_{CE}=1.0\text{V}$		0.95	1.1	V
h_{FE}	$V_{CE}=5.0\text{V}, I_C=10\text{mA}$	100	170		
h_{FE}	$V_{CE}=5.0\text{V}, I_C=500\text{mA}$	100	165	300	
h_{FE}	$V_{CE}=5.0\text{V}, I_C=3.0\text{A}$	40	75		
f_T	$V_{CE}=10\text{V}, I_C=500\text{mA}, f=1.0\text{MHz}$	8.0			MHz

R3 (1-March 2010)

CZT3120

**SURFACE MOUNT
NPN SILICON SWITCHING
POWER TRANSISTOR**



SOT-223 CASE - MECHANICAL OUTLINE

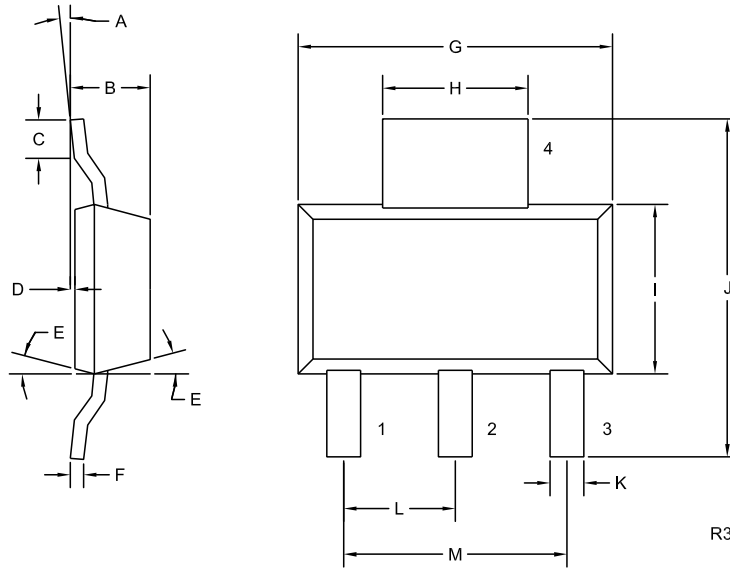

LEAD CODE:

- 1) Base
- 2) Collector
- 3) Emitter
- 4) Collector

MARKING:

FULL PART NUMBER

DIMENSIONS				
SYMBOL	INCHES		MILLIMETERS	
	MIN	MAX	MIN	MAX
A	0°	10°	0°	10°
B	0.059	0.071	1.50	1.80
C	0.018	—	0.45	—
D	0.000	0.004	0.00	0.10
E	15°		15°	
F	0.009	0.014	0.23	0.35
G	0.248	0.264	6.30	6.70
H	0.114	0.122	2.90	3.10
I	0.130	0.146	3.30	3.70
J	0.264	0.287	6.70	7.30
K	0.024	0.033	0.60	0.85
L	0.091		2.30	
M	0.181		4.60	

SOT-223 (REV: R3)

R3 (1-March 2010)