

CMR1S-01
CMR1S-02

**SURFACE MOUNT
SUPER FAST RECOVERY
SILICON RECTIFIER
1 AMP, 100 AND 200 VOLTS**



SMB CASE



www.centralemi.com

DESCRIPTION:

The CENTRAL SEMICONDUCTOR CMR1S-01 Series 1.0 Amp Surface Mount Silicon Super Fast Recovery Rectifier is a high quality, well constructed, highly reliable component designed for use in all types of commercial, industrial, entertainment, computer, and automotive applications. To order devices on 12mm Tape and Reel (3000/13" Reel), add TR13 suffix to part number.

**MARKING CODES: CMR1S-01: CSF01
CMR1S-02: CSF02**

FEATURES:

- Faster switching speed (35ns max)
- Lower V_F (0.95V)
- Runs cooler than Ultra Fast Rectifier
- Low cost - High reliability
- Glass passivated chip
- "C" bend construction provides strain relief when mounted on pc board

MAXIMUM RATINGS: ($T_A=25^\circ\text{C}$ unless otherwise noted)

	SYMBOL	CMR1S-01	CMR1S-02	UNITS
Peak Repetitive Reverse Voltage	V_{RRM}	100	200	V
DC Blocking Voltage	V_R	100	200	V
RMS Reverse Voltage	$V_{R(RMS)}$	70	140	V
Average Forward Current	I_O		1.0	A
Peak Forward Surge Current, $t_p=8.3\text{ms}$	I_{FSM}		30	A
Operating and Storage Junction Temperature	T_J, T_{stg}		-65 to +150	$^\circ\text{C}$
Thermal Resistance	θ_{JL}		20	$^\circ\text{C/W}$

ELECTRICAL CHARACTERISTICS: ($T_A=25^\circ\text{C}$ unless otherwise noted)

SYMBOL	TEST CONDITIONS	TYP	MAX	UNITS
I_R	$V_R=\text{Rated } V_{RRM}$		5.0	μA
I_R	$V_R=\text{Rated } V_{RRM}, T_A=100^\circ\text{C}$		500	μA
V_F	$I_F=1.0\text{A}$		0.95	V
t_{rr}	$I_F=0.5\text{A}, I_R=1.0\text{A}, I_{rr}=0.25\text{A}$		35	ns
C_J	$V_R=4.0\text{V}, f=1.0\text{MHz}$	10		pF

R4 (3-February 2010)

CMR1S-01
CMR1S-02

SURFACE MOUNT
SUPER FAST RECOVERY
SILICON RECTIFIER
1 AMP, 100 AND 200 VOLTS



SMB CASE - MECHANICAL OUTLINE

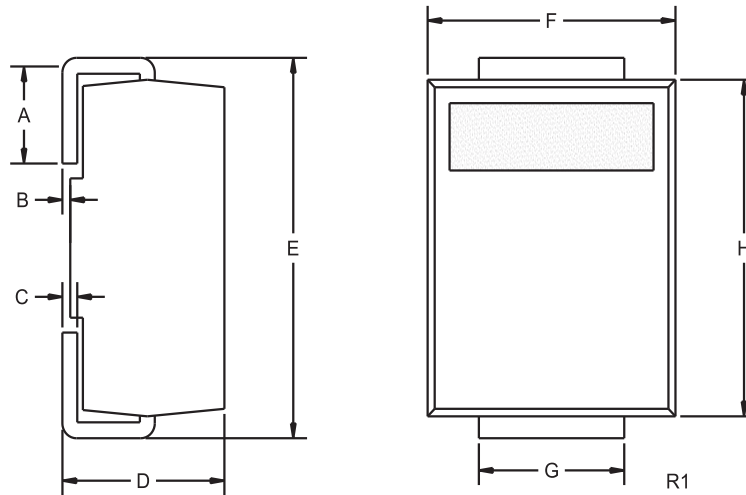

DEVICE	MARKING CODE
CMR1S-01	CSF01
CMR1S-02	CSF02

SYMBOL	DIMENSIONS			
	INCHES		MILLIMETERS	
	MIN	MAX	MIN	MAX
A	0.030	0.060	0.76	1.52
B	0.004	0.008	0.10	0.20
C	0.006	0.012	0.15	0.30
D	0.086	0.096	2.18	2.44
E	0.200	0.220	5.08	5.59
F	0.130	0.150	3.30	3.81
G	0.077	0.083	1.96	2.11
H	0.160	0.180	4.06	4.57

SMB (REV: R1)

R4 (3-February 2010)