

CMSH2-20L
CMSH2-40L

**SURFACE MOUNT
LOW V_F
SILICON SCHOTTKY RECTIFIER
2 AMP, 20 AND 40 VOLTS**

**LOW
 V_F**



SMB CASE



www.centrasemi.com

DESCRIPTION:

The CENTRAL SEMICONDUCTOR CMSH2-20L Series 2.0 Amp Surface Mount Low V_F Schottky Rectifier is a high quality, well constructed, highly reliable component designed for use in all types of commercial, industrial, entertainment, computer, and automotive applications where high efficiency is required. To order devices on 12mm Tape and Reel (3000/13" Reel), add TR13 suffix to part number.

**MARKING CODES: CMSH2-20L: CS220L
CMSH2-40L: CS240L**

FEATURES:

- Low forward voltage drop
- Low cost
- Flammability classification UL94V-0
- High reliability
- High current capability
- "C" bend construction provides strain relief when mounted on pc board
- Superior lot to lot consistency

MAXIMUM RATINGS: ($T_A=25^\circ\text{C}$ unless otherwise noted)

	SYMBOL	CMSH2-20L	CMSH2-40L	UNITS
Peak Repetitive Reverse Voltage	V_{RRM}	20	40	V
DC Blocking Voltage	V_R	20	40	V
RMS Reverse Voltage	$V_{R(RMS)}$	14	28	V
Average Forward Current ($T_L=105^\circ\text{C}$)	I_O		2.0	A
Peak Forward Surge Current, $t_p=8.3\text{ms}$	I_{FSM}		50	A
Operating and Storage Junction Temperature	T_J, T_{stg}	-65 to +150		$^\circ\text{C}$
Thermal Resistance	θ_{JL}	20		$^\circ\text{C/W}$

ELECTRICAL CHARACTERISTICS: ($T_A=25^\circ\text{C}$ unless otherwise noted)

SYMBOL	TEST CONDITIONS	TYP	MAX	UNITS
I_R	$V_R=\text{Rated } V_{RRM}$		0.50	mA
I_R	$V_R=\text{Rated } V_{RRM}, T_A=100^\circ\text{C}$		20	mA
V_F	$I_F=2.0\text{A}$		0.40	V
C_J	$V_R=4.0\text{V}, f=1.0\text{MHz}$	150		pF

CMSH2-20L
CMSH2-40L

SURFACE MOUNT
LOW V_F
SILICON SCHOTTKY RECTIFIER
2 AMP, 20 AND 40 VOLTS



SMB CASE - MECHANICAL OUTLINE

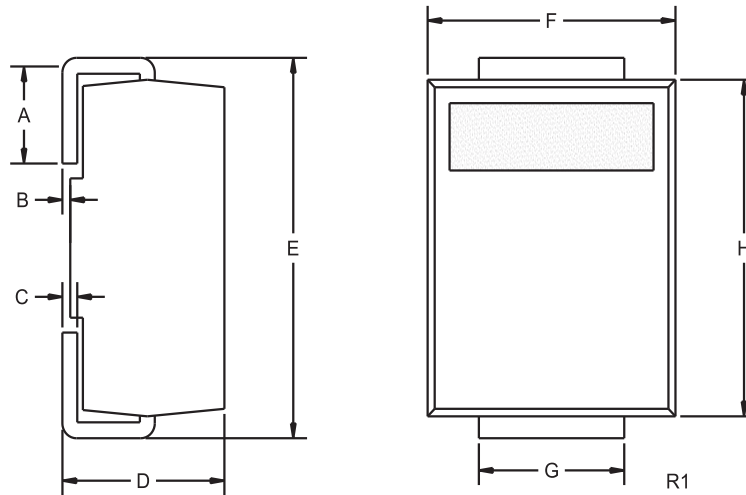

DEVICE	MARKING CODE
CMSH2-20L	CS220L
CMSH2-40L	CS240L

SYMBOL	DIMENSIONS			
	INCHES		MILLIMETERS	
	MIN	MAX	MIN	MAX
A	0.030	0.060	0.76	1.52
B	0.004	0.008	0.10	0.20
C	0.006	0.012	0.15	0.30
D	0.086	0.096	2.18	2.44
E	0.200	0.220	5.08	5.59
F	0.130	0.150	3.30	3.81
G	0.077	0.083	1.96	2.11
H	0.160	0.180	4.06	4.57

SMB (REV: R1)

R3 (8-February 2010)