

CMR1F-02M CMR1F-06M
 CMR1F-04M CMR1F-10M

**SURFACE MOUNT
 FAST RECOVERY
 SILICON RECTIFIER
 1 AMP, 200 THRU 1000 VOLTS**



SMA CASE



www.centrasemi.com

DESCRIPTION:

The CENTRAL SEMICONDUCTOR CMR1F-02M Series 1.0 Amp Surface Mount Silicon Rectifier is a high quality, well constructed, highly reliable component designed for use in all types of commercial, industrial, entertainment, computer, and automotive applications where small size is required. The SMA case occupies 30% less board space than the SMB case. To order devices on 12mm Tape and Reel (5000/13" Reel), add TR13 suffix to part number.

MARKING CODE: SEE MARKING CODE TABLE ON FOLLOWING PAGE

FEATURES:

- Special selections available
- Low cost
- Superior lot to lot consistency
- High reliability
- "C" bend construction provides strain relief when mounted on pc board
- Glass passivated chip

MAXIMUM RATINGS: ($T_A=25^\circ\text{C}$ unless otherwise noted)

	SYMBOL	CMR1F-02M	CMR1F-04M	CMR1F-06M	CMR1F-10M	UNITS
Peak Repetitive Reverse Voltage	V_{RRM}	200	400	600	1000	V
DC Blocking Voltage	V_R	200	400	600	1000	V
RMS Reverse Voltage	$V_{R(RMS)}$	140	280	420	700	V
Average Forward Current ($T_L=120^\circ\text{C}$)	I_O			1.0		A
Peak Forward Surge Current, $t_p=8.3\text{ms}$	I_{FSM}			30		A
Operating and Storage						
Junction Temperature	T_J, T_{stg}			-65 to +150		$^\circ\text{C}$
Thermal Resistance	θ_{JL}			30		$^\circ\text{C/W}$

ELECTRICAL CHARACTERISTICS: ($T_A=25^\circ\text{C}$ unless otherwise noted)

SYMBOL	TEST CONDITIONS	TYP	MAX	UNITS
I_R	$V_R=\text{Rated } V_{RRM}$		5.0	μA
I_R	$V_R=\text{Rated } V_{RRM}, T_A=125^\circ\text{C}$		200	μA
V_F	$I_F=1.0\text{A}$		1.3	V
C_J	$V_R=4.0\text{V}, f=1.0\text{MHz}$	15		pF
t_{rr}	$I_F=0.5\text{A}, I_R=1.0\text{A}, I_{rr}=0.25\text{A}$ (CMR1F-02M, -04M)		150	ns
t_{rr}	$I_F=0.5\text{A}, I_R=1.0\text{A}, I_{rr}=0.25\text{A}$ (CMR1F-06M)		250	ns
t_{rr}	$I_F=0.5\text{A}, I_R=1.0\text{A}, I_{rr}=0.25\text{A}$ (CMR1F-10M)		500	ns

CMR1F-02M CMR1F-06M
 CMR1F-04M CMR1F-10M



**SURFACE MOUNT
 FAST RECOVERY
 SILICON RECTIFIER
 1 AMP, 200 THRU 1000 VOLTS**

SMA CASE - MECHANICAL OUTLINE

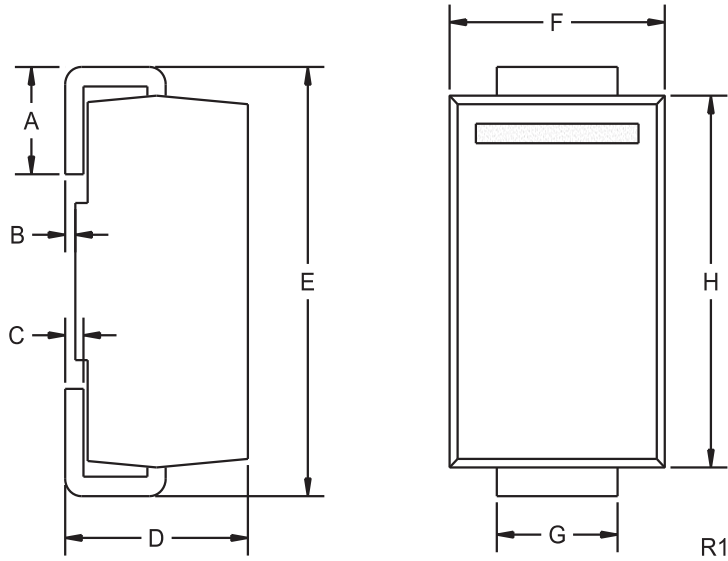

DEVICE	MARKING CODE
CMR1F-02M	CF02M
CMR1F-04M	CF04M
CMR1F-06M	CF06M
CMR1F-10M	CF10M

SYMBOL	DIMENSIONS			
	INCHES		MILLIMETERS	
	MIN	MAX	MIN	MAX
A	0.030	0.060	0.76	1.52
B	0.004	0.008	0.10	0.20
C	0.006	0.012	0.15	0.30
D	0.078	0.103	1.98	2.62
E	0.188	0.220	4.78	5.59
F	0.090	0.115	2.29	2.92
G	0.050	0.070	1.27	1.78
H	0.157	0.181	3.99	4.60

SMA (REV: R1)

R2 (3-February 2010)