

CMKSH2-4LR

**SURFACE MOUNT
TRIPLE ISOLATED SILICON
LOW V_F SCHOTTKY DIODES**



www.centrasemi.com

DESCRIPTION:

The CENTRAL SEMICONDUCTOR CMKSH2-4LR contains three (3) Isolated Silicon Low V_F Schottky Diodes, epoxy molded in a SOT-363 surface mount package. This ULTRAmimi™ device has been designed for switching applications requiring a low forward voltage drop.

MARKING CODE: CHTL

ULTRAmimi™



SOT-363 CASE

MAXIMUM RATINGS: ($T_A=25^\circ\text{C}$)

Peak Repetitive Reverse Voltage
Continuous Forward Current
Peak Repetitive Forward Current
Peak Forward Surge Current, $t_p=10\text{ms}$
Power Dissipation
Operating and Storage Junction Temperature
Thermal Resistance

SYMBOL

V_{RRM}	40
I_F	200
I_{FRM}	350
I_{FSM}	1.0
P_D	350
T_J, T_{stg}	-65 to +150
Θ_{JA}	357

UNITS

V
mA
mA
A
mW
$^\circ\text{C}$
$^\circ\text{C/W}$

ELECTRICAL CHARACTERISTICS PER DIODE: ($T_A=25^\circ\text{C}$ unless otherwise noted)

SYMBOL	TEST CONDITIONS	MIN	TYP	MAX	UNITS
I_R	$V_R=20\text{V}$		11	50	μA
BV_R	$I_R=100\mu\text{A}$	40	53		V
V_F	$I_F=10\text{mA}$		0.24	0.325	V
V_F	$I_F=100\text{mA}$		0.35	0.40	V
V_F	$I_F=200\text{mA}$		0.42	0.50	V
C_T	$V_R=4.0\text{V}, f=1.0\text{MHz}$		8.5	10	pF
t_{rr}	$I_F=I_R=10\text{mA}, I_{rr}=1.0\text{mA}, R_L=100\Omega$		4.0	5.0	ns

R3 (13-August 2010)

CMKSH2-4LR
SURFACE MOUNT
TRIPLE ISOLATED SILICON
LOW V_F SCHOTTKY DIODES



SOT-363 CASE - MECHANICAL OUTLINE

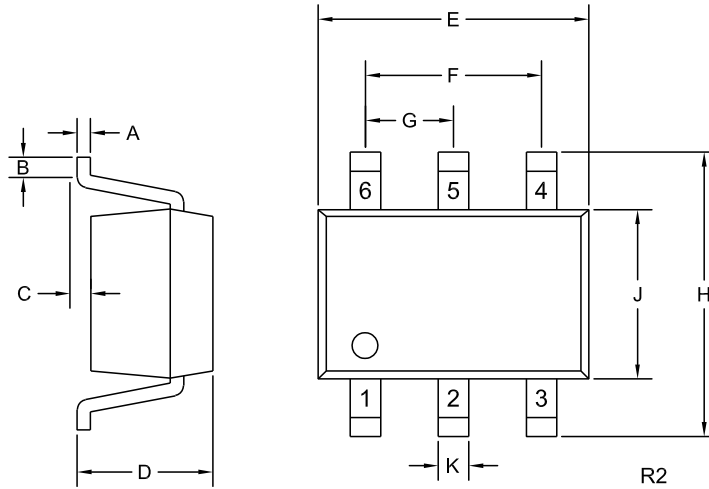

PIN CONFIGURATION

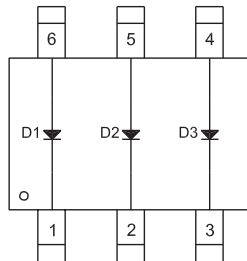

LEAD CODE:

- 1) Cathode D1
- 2) Cathode D2
- 3) Cathode D3
- 4) Anode D3
- 5) Anode D2
- 6) Anode D1

MARKING CODE: CHTL

SYMBOL	INCHES		MILLIMETERS	
	MIN	MAX	MIN	MAX
A	0.004	0.010	0.10	0.25
B	0.005	-	0.12	-
C	0.000	0.004	0.00	0.10
D	0.031	0.043	0.80	1.10
E	0.071	0.087	1.80	2.20
F	0.051		1.30	
G	0.026		0.65	
H	0.075	0.091	1.90	2.30
J	0.043	0.055	1.10	1.40
K	0.006	0.012	0.15	0.30

SOT-363 (REV: R2)

R3 (13-August 2010)