

TRIAC

BT136D

**TO-220
Plastic Package**

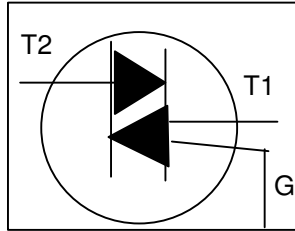
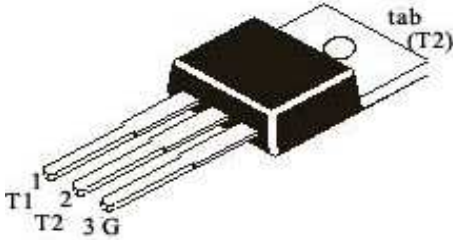

For use in General Purpose Bidirectional Switching and Phase Control Applications

ABSOLUTE MAXIMUM RATINGS

PARAMETER	SYMBOL	TEST CONDITION	VALUE	UNIT
Repetitive Peak Off State Voltage	V_{DRM}		600	V
RMS on State Current	$I_{T(RMS)}$	full sine wave, $T_{mb} \leq 107^{\circ}C$	4.0	A
Non Repetitive Peak on State Current	I_{TSM}	full sine wave, $T_j = 25^{\circ}C$ prior to Surge		
		$t = 20ms$	25	A
		$t = 16.7ms$	27	A
I^2t for Fusing	I^2t	$t = 10ms$	3.1	A^2s
Repetitive Rate of Rise of on State Current After Triggering	di_T/dt	$I_{TM} = 6A, I_G = 0.2A,$ $di_G/dt = 0.2A/\mu s$		
		T2+ G+	50	A/ μs
		T2+ G-	50	A/ μs
		T2- G-	50	A/ μs
		T2- G+	10	A/ μs
Peak Gate Current	I_{GM}		2.0	A
Peak Gate Voltage	V_{GM}		5.0	V
Peak Gate Power	P_{GM}		5.0	W
Average Gate Power	$P_{G(AV)}$	Over any 20ms period	0.5	W
Storage Temperature	T_{stg}		- 40 to 150	$^{\circ}C$
Operating Junction Temperature	T_j		125	$^{\circ}C$

THERMAL RESISTANCE

Junction to Mounting Base	$R_{th(j-mb)}$	full cycle	3.0 max	K/W
		half cycle	3.7 max	K/W
Junction to Ambient	$R_{th(j-a)}$	in free air	60 typ	K/W

ELECTRICAL CHARACTERISTICS ($T_j = 25^{\circ}C$ unless specified otherwise)

PARAMETER	SYMBOL	TEST CONDITION	MIN	MAX	UNIT
Gate Trigger Current	I_{GT}	$V_D = 12V, I_T = 0.1A$			
		T2+ G+		5.0	mA
		T2+ G-		5.0	mA
		T2- G-		5.0	mA
		T2- G+		10	mA

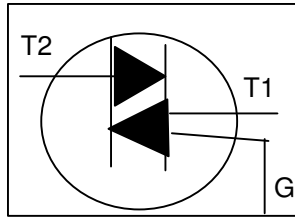
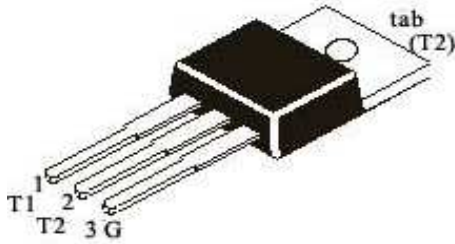

ELECTRICAL CHARACTERISTICS (T_J=25°C unless specified otherwise)

PARAMETER	SYMBOL	TEST CONDITION	MIN	MAX	UNIT
Latching Current	I _L	V _D =12V, I _{GT} =0.1A			
		T2+ G+		10	mA
		T2+ G-		15	mA
		T2- G-		10	mA
		T2- G+		30	mA
Holding Current	I _H	V _D =12V, I _{GT} =0.1A		10	mA
On State Voltage	V _T	I _T =5A		1.7	V
Gate Trigger Voltage	V _{GT}	V _D =12V, I _T =0.1A		1.5	V
		V _D =400V, I _T =0.1A, T _J =125°C	0.25		V
Off State Leakage Current	I _D	V _D = V _{DRM} =max, T _J =125°C		0.5	mA

DYNAMIC CHARACTERISTICS

PARAMETER	SYMBOL	TEST CONDITION	MIN	TYP	MAX	UNIT
Critical Rate of Rise of off State Voltage	d _V /dt	V _{DM} =67% V _{DRM} =max, T _J =125°C, exponential waveform, gate open circuit, R _{GK} =1KΩ		5		V/μs
Gate Controlled turn on time	t _{gt}	I _{TM} =6A, V _D =V _{DRM} max, I _G =0.1A, dI _G /dt=5A/μs		2		μs

BT136DRev030205E

TO-220 Plastic Package

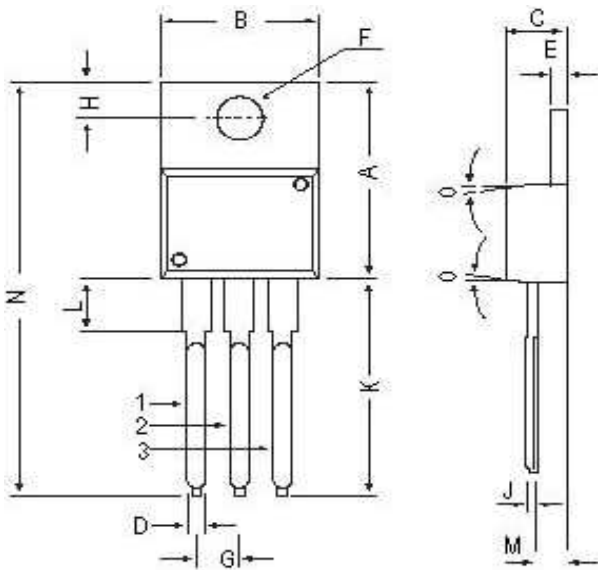

DIM	MIN	MAX
A	14.42	16.51
B	9.63	10.67
C	3.56	4.83
D	—	0.90
E	1.15	1.40
F	3.75	3.88
G	2.29	2.79
H	2.54	3.43
J	—	0.56
K	12.70	14.73
L	2.80	4.07
M	2.03	2.92
N	—	31.24
O	7 DEG	

All dimensions in mm.

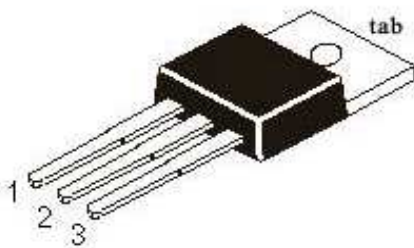

Pin Configuration

- 1. Main Terminal 1
- 2. Main Terminal 2
- 3. Gate
- tab Main Terminal 2

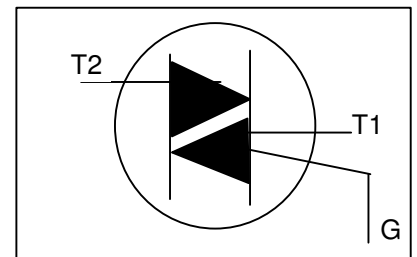

TO-220 Tube Packing

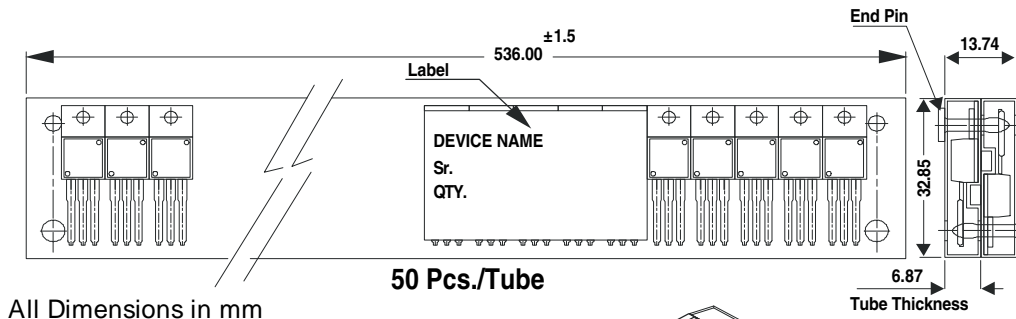

All Dimensions in mm

50 Pcs./Tube

AMMO PACK SIZE

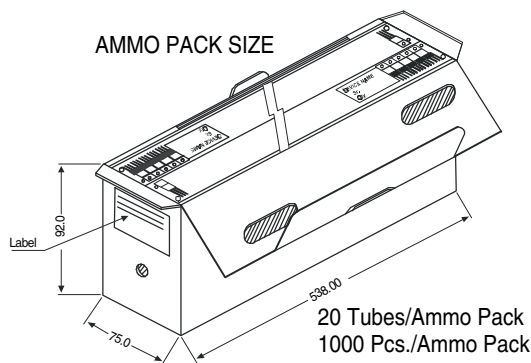

20 Tubes/Ammo Pack
1000 Pcs./Ammo Pack

Packing Detail

PACKAGE	STANDARD PACK		INNER CARTON BOX		OUTER CARTON BOX		
	Details	Net Weight/Qty	Size	Qty	Size	Qty	Gr Wt
TO-220	200 pcs/polybag	396 gm/200 pcs	3" x 7.5" x 7.5"	1.0K	17" x 15" x 13.5"	16.0K	36 kgs
	50 pcs/tube	120 gm/50 pcs	3.5" x 3.7" x 21.5"	1.0K	19" x 19" x 19"	10.0K	29 kgs

Disclaimer

The product information and the selection guides facilitate selection of the CDIL's Discrete Semiconductor Device(s) best suited for application in your product(s) as per your requirement. It is recommended that you completely review our Data Sheet(s) so as to confirm that the Device(s) meet functionality parameters for your application. The information furnished in the Data Sheet and on the CDIL Web Site/CD are believed to be accurate and reliable. CDIL however, does not assume responsibility for inaccuracies or incomplete information. Furthermore, CDIL does not assume liability whatsoever, arising out of the application or use of any CDIL product; neither does it convey any license under its patent rights nor rights of others. These products are not designed for use in life saving/support appliances or systems. CDIL customers selling these products (either as individual Discrete Semiconductor Devices or incorporated in their end products), in any life saving/support appliances or systems or applications do so at their own risk and CDIL will not be responsible for any damages resulting from such sale(s).

CDIL strives for continuous improvement and reserves the right to change the specifications of its products without prior notice.



CDIL is a registered Trademark of
Continental Device India Limited

C-120 Naraina Industrial Area, New Delhi 110 028, India.

Telephone + 91-11-2579 6150, 5141 1112 Fax + 91-11-2579 5290, 5141 1119

e-mail@cdil.com www.cdilsemi.com