



Continental Device India Limited

An ISO/TS 16949, ISO 9001 and ISO 14001 Certified Company



ISO 14001



DNV

# KBU (4 Leads) In-line Leaded Package

## Package Outline and Packaging Information

### KBU Leaded Plastic Package

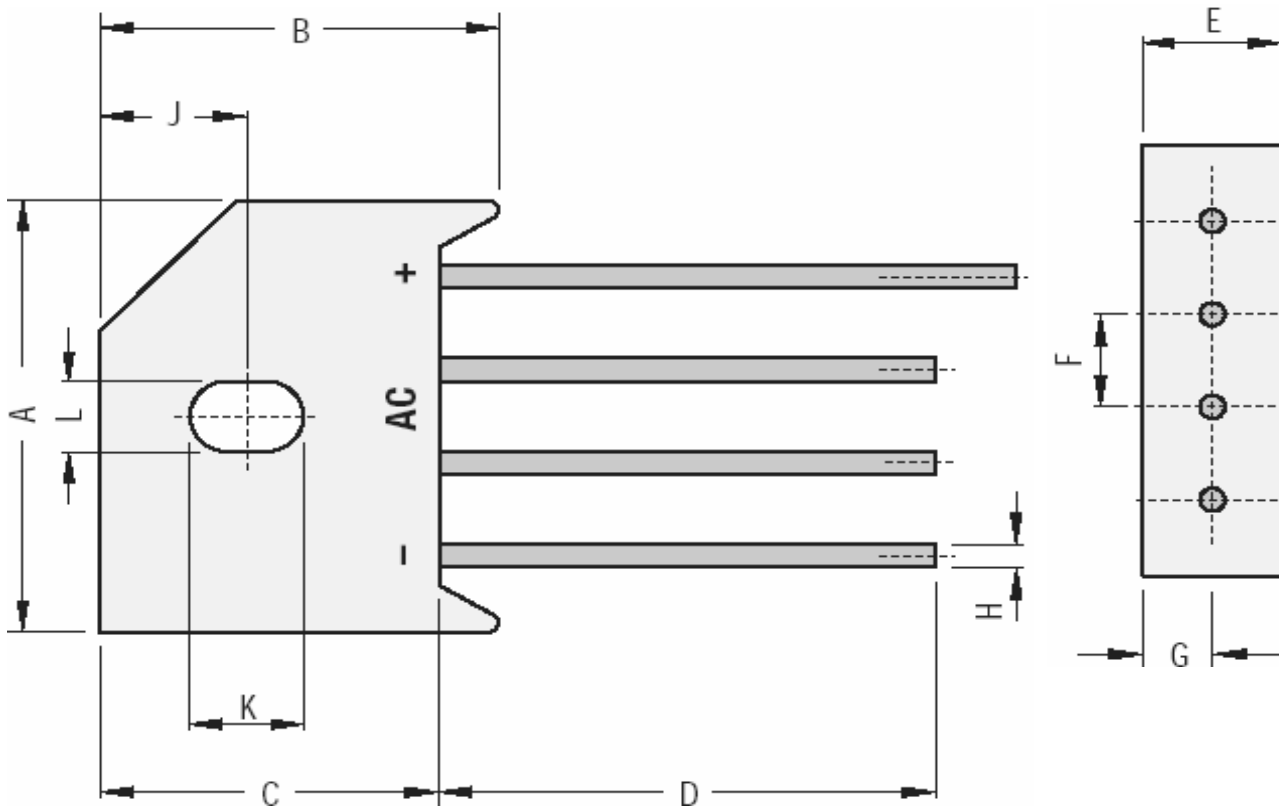

DIM	Min	Max
A	22.70	23.70
B	18.80	19.80
C	16.80	17.80
D	25.40	
E	6.80	7.10
F	4.60	5.60

DIM	Min	Max
G		3.50
H	1.20	1.30
J		7.50
K		5.70
L		3.80

All Dimensions are in mm

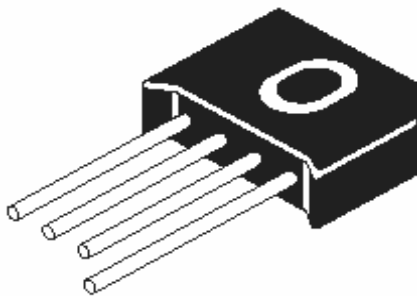

## Packaging Information

Package/ Case Type	Packaging Type	Std. Packing Qty	Inner Carton			Outer Carton		
			Qty	Size L x W x H (cm)	Gross Weight (Kg)	Qty	Size L x W x H (cm)	Gross Weight (Kg)
KBU	Bulk	400						

Bulk: Lose in Poly bags

## Component Disposal Instructions

1. CDIL Semiconductor Devices are non-recyclable RoHS compliant, customers are requested to please dispose as per prevailing Environmental Legislation of their Country.
2. In Europe, please dispose as per EU Directive 2002/96/EC on Waste Electrical and Electronic Equipment (WEEE).

## Customer Notes

### Disclaimer

The product information and the selection guides facilitate selection of the CDIL's Semiconductor Device(s) best suited for application in your product(s) as per your requirement. It is recommended that you completely review our Data Sheet(s) so as to confirm that the Device(s) meet functionality parameters for your application. The information furnished in the Data Sheet and on the CDIL Web Site/CD are believed to be accurate and reliable. CDIL however, does not assume responsibility for inaccuracies or incomplete information. Furthermore, CDIL does not assume liability whatsoever, arising out of the application or use of any CDIL product; neither does it convey any license under its patent rights nor rights of others. These products are not designed for use in life saving/support appliances or systems. CDIL customers selling these products (either as individual Discrete Semiconductor Devices or incorporated in their end products), in any life saving/support appliances or systems or applications do so at their own risk and CDIL will not be responsible for any damages resulting from such sale(s).

CDIL strives for continuous improvement and reserves the right to change the specifications of its products without prior notice.



CDIL is a registered Trademark of  
**Continental Device India Limited**

C-120 Naraina Industrial Area, New Delhi 110 028, India.

Telephone + 91-11-2579 6150, 4141 1112 Fax + 91-11-2579 5290, 4141 1119

email@cdil.com

www.cdilsemi.com