

PNP SILICON PLANAR EPITAXIAL TRANSISTOR

CSA539

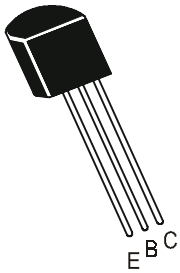

TO-92
Plastic Package

Complementary CSC815

Low Frequency Amplifier

ABSOLUTE MAXIMUM RATINGS (Ta=25°C)

DESCRIPTION	SYMBOL	VALUE	UNIT
Collector Base Voltage	V_{CBO}	60	V
Collector Emitter Voltage	V_{CEO}	45	V
Emitter Base Voltage	V_{EBO}	5	V
Collector Current	I_C	200	mA
Collector Dissipation	P_C	400	mW
Operating And Storage Junction Temperature Range	T_j, T_{stg}	-55 to +150	°C

ELECTRICAL CHARACTERISTICS (Ta=25°C unless specified otherwise)

DESCRIPTION	SYMBOL	TEST CONDITION	MIN	TYP	MAX	UNIT
Collector Base Voltage	V_{CBO}	$I_C=100\mu A, I_E=0$	60	-	-	V
Collector Emitter Voltage	V_{CEO}	$I_C=10mA, I_B=0$	45	-	-	V
Emitter Base Voltage	V_{EBO}	$I_E=10\mu A, I_C=0$	5	-	-	V
Collector Cut off Current	I_{CBO}	$V_{CB}=45V, I_E = 0$	-	-	100	nA
Emitter Cut off Current	I_{EBO}	$V_{EB}=3V, I_C = 0$	-	-	100	nA
DC Current Gain	h_{FE}	$V_{CE}=1V, I_C=50mA$	40	-	240	
Base Emitter on Voltage	$V_{BE(on)}$	$V_{CE}=1V, I_C=10mA$	0.60	-	0.90	V
Collector Emitter Saturation Voltage	$V_{CE(sat)}$	$I_C=150mA, I_B=15mA$	-	-	0.5	V
Base Emitter Saturation Voltage	$V_{BE(sat)}$	$I_C=150mA, I_B=15mA$	-	-	1.2	V

Classification	R	O	Y
h_{FE}	40 - 80	70 - 140	120 - 240

TO-92 Plastic Package

TO-92 Transistors on Tape and Ammo Pack

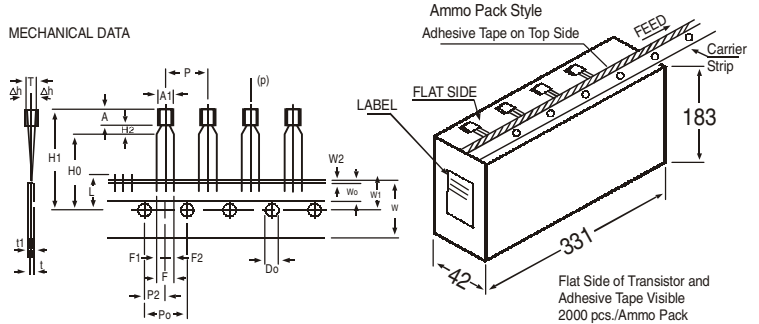
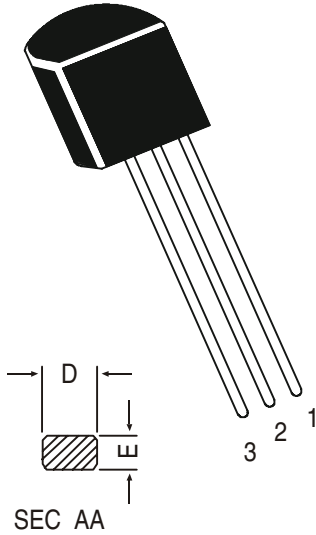
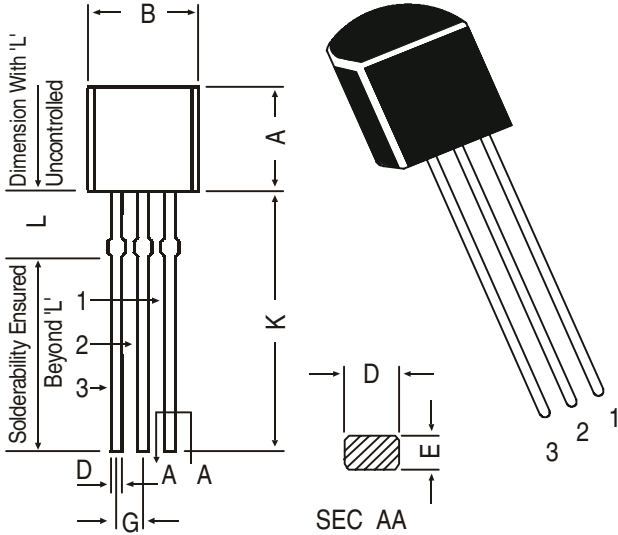

All dimensions in mm unless specified otherwise

ITEM	SYMBOL	SPECIFICATION				REMARKS
		MIN.	NOM.	MAX.	TOL.	
BODY WIDTH	A1	4.0		4.8		
BODY HEIGHT	A	4.8		5.2		
BODY THICKNESS	T	3.9		4.2		
PITCH OF COMPONENT	P		12.7		±1	
FEED HOLE PITCH	Po		12.7		±0.3	
FEED HOLE CENTRE TO COMPONENT CENTRE	P2		6.35		±0.4	CUMULATIVE PITCH ERROR 1.0 mm/20 PITCH TO BE MEASURED AT BOTTOM OF CLINCH
DISTANCE BETWEEN OUTER LEADS	F		5.08		+0.6	
COMPONENT ALIGNMENT	Δh		0	1	-0.2	AT TOP OF BODY
TAPE WIDTH	W		18		±0.5	
HOLD-DOWN TAPE WIDTH	Wo		6		±0.2	
HOLE POSITION	W1		9		+0.7 -0.5	
HOLD-DOWN TAPE POSITION	W2		0.5		±0.2	
LEAD WIRE CLINCH HEIGHT	Ho		16		±0.5	
COMPONENT HEIGHT	H1		23.25			
LENGTH OF SNIPPED LEADS	L		11.0			
FEED HOLE DIAMETER	Do		4		±0.2	
TOTAL TAPE THICKNESS	t		1.2			t1 0.3 - 0.6
LEAD - TO - LEAD DISTANCE F1,	F2		2.54		+0.4 -0.1	
CLINCH HEIGHT	H2		3			
PULL - OUT FORCE	(P)		6N			

NOTES

1. MAXIMUM ALIGNMENT DEVIATION BETWEEN LEADS NOT TO BE GREATER THAN 0.2 mm.
2. MAXIMUM NON-CUMULATIVE VARIATION BETWEEN TAPE FEED HOLES SHALL NOT EXCEED 1 mm IN 20 PITCHES.
3. HOLDDOWN TAPE NOT TO EXCEED BEYOND THE EDGE(S) OF CARRIER TAPE AND THERE SHALL BE NO EXPOSURE OF ADHESIVE.
4. NO MORE THAN 3 CONSECUTIVE MISSING COMPONENTS ARE PERMITTED.
5. A TAPE TRAILER, HAVING AT LEAST THREE FEED HOLES ARE REQUIRED AFTER THE LAST COMPONENT.
6. SPLICES SHALL NOT INTERFERE WITH THE SPROCKET FEED HOLES.

DIM	MIN.	MAX.
A	4.32	5.33
B	4.45	5.20
C	3.18	4.19
D	0.41	0.55
E	0.35	0.50
F	5 DEG	
G	1.14	1.40
H	1.14	1.53
K	12.70	—
L	1.982	2.082

All dimensions in mm.

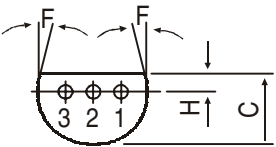

PIN CONFIGURATION

1. COLLECTOR
2. BASE
3. EMITTER

Packing Detail

PACKAGE	STANDARD PACK		INNER CARTON BOX		OUTER CARTON BOX		
	Details	Net Weight/Qty	Size	Qty	Size	Qty	Gr Wt
TO-92 Bulk	1K/polybag	200 gm/1K pcs	3" x 7.5" x 7.5"	5K	17" x 15" x 13.5"	80K	23 kgs
TO-92 T&A	2K/ammo box	645 gm/2K pcs	12.5" x 8" x 1.8"	2K	17" x 15" x 13.5"	32K	12.5 kgs

Disclaimer

The product information and the selection guides facilitate selection of the CDIL's Discrete Semiconductor Device(s) best suited for application in your product(s) as per your requirement. It is recommended that you completely review our Data Sheet(s) so as to confirm that the Device(s) meet functionality parameters for your application. The information furnished in the Data Sheet and on the CDIL Web Site/CD are believed to be accurate and reliable. CDIL however, does not assume responsibility for inaccuracies or incomplete information. Furthermore, CDIL does not assume liability whatsoever, arising out of the application or use of any CDIL product; neither does it convey any license under its patent rights nor rights of others. These products are not designed for use in life saving/support appliances or systems. CDIL customers selling these products (either as individual Discrete Semiconductor Devices or incorporated in their end products), in any life saving/support appliances or systems or applications do so at their own risk and CDIL will not be responsible for any damages resulting from such sale(s).

CDIL strives for continuous improvement and reserves the right to change the specifications of its products without prior notice.



CDIL is a registered Trademark of

Continental Device India Limited

C-120 Naraina Industrial Area, New Delhi 110 028, India.
Telephone + 91-11-2579 6150, 5141 1112 Fax + 91-11-2579 5290, 5141 1119
email@cdil.com www.cdilsemi.com