

NPN SILICON PLANAR EPITAXIAL TRANSISTORS

2N3704 2N3705

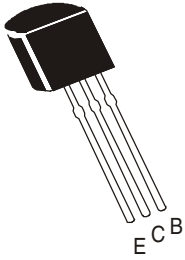

**TO-92
Plastic Package**

For Lead Free Parts, Device Part # will be Prefixed with "T"

Amplifier Transistor

ABSOLUTE MAXIMUM RATINGS (T_a=25°C)

DESCRIPTION	SYMBOL	2N3704	2N3705	UNIT
Collector Emitter Voltage	V _{CEO}	30		V
Collector Base Voltage	V _{CBO}	50		V
Emitter Base Voltage	V _{EBO}	5.0		V
Collector Current Continuous	I _C	600		mA
Total Device Dissipation at T _a =25°C	P _D	625		mW
Derate Above 25°C		5.0		mW/°C
Operating And Storage Junction Temperature Range	T _j , T _{stg}	- 55 to +150		°C

THERMAL RESISTANCE

Junction to Ambient in free air	R _{th(j-a)}	200	°C/W
---------------------------------	----------------------	-----	------

ELECTRICAL CHARACTERISTICS (T_a=25°C unless specified otherwise)

DESCRIPTION	SYMBOL	TEST CONDITION	MIN	MAX	UNIT
Collector Emitter Voltage	V _{CEO}	I _C =1mA, I _B =0	30		V
Collector Base Voltage	V _{CBO}	I _C =100µA, I _E =0	50		V
Emitter Base Voltage	V _{EBO}	I _E =100µA, I _C =0	5.0		V
DC Current Gain	*h _{FE}	V _{CE} =2V, I _C =50mA	2N3704	100	300
			2N3705	50	150
Collector Cut Off Current	I _{CBO}	V _{CB} =20V, I _E =0		100	nA
Emitter Cut Off Current	I _{EBO}	V _{EB} =3V, I _C =0		100	nA
Collector Emitter Saturation Voltage	*V _{CE(sat)}	I _C =100mA, I _B =5mA	2N3704	0.6	V
			2N3705	0.8	V
Base Emitter (On) Voltage	*V _{BE(on)}	I _C =100mA, V _{CE} =2V	0.5	1.0	V

DYNAMIC CHARACTERISTICS

DESCRIPTION	SYMBOL	TEST CONDITION	MIN	MAX	UNIT
Transistors Frequency	f _T	I _C =50mA, V _{CE} =2V, f=20MHz	100		MHz
Output Capacitance	C _{ob}	I _E =0, V _{CB} =10V, f=1MHz		12	pF

*Pulse Test: Pulse Width ≤ 300µs, Duty Cycle ≤ 2%

2N3704_2N3705Rev_1 081205E

**TO-92
Plastic Package**

For Lead Free Parts, Device Part # will be Prefixed with "T"

TO-92 Plastic Package

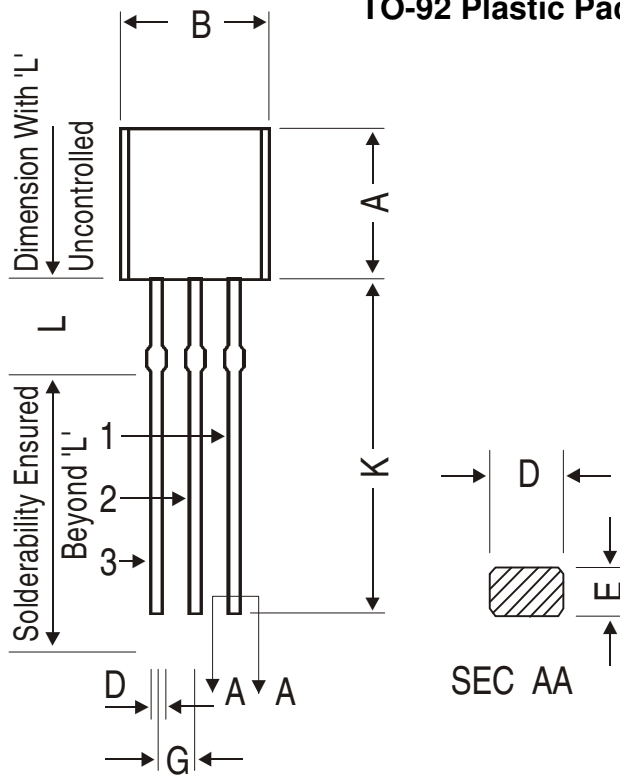

DIM	MIN.	MAX.
A	4.32	5.33
B	4.45	5.20
C	3.18	4.19
D	0.41	0.55
E	0.35	0.50
F	5 DEG	
G	1.14	1.40
H	1.20	1.40
K	12.70	—
L	1.982	2.082
M	1.03	1.20

All dimensions are in mm

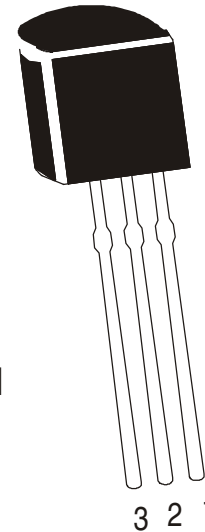
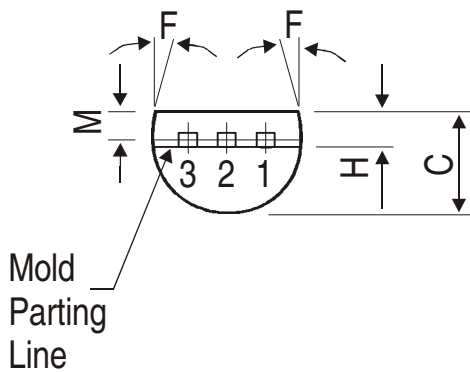

PIN CONFIGURATION

1. BASE
2. COLLECTOR
3. EMITTER

The TO-92 Package, Tape and Ammo Pack Drawings are correct as on the date of issue/revision of this Data Sheet.

The currently valid dimensions and information, may please be confirmed from the TO-92 Drawing in the Packages and Packing Section of the Product Catalogue.

Packing Details

PACKAGE	STANDARD PACK		INNER CARTON BOX		OUTER CARTON BOX		
	Details	Net Weight/Qty	Size	Qty	Size	Qty	Gr Wt
TO-92 Bulk	1K/polybag	200 gm/1K pcs	3" x 7.5" x 7.5"	5K	17" x 15" x 13.5"	80K	23 kgs
TO-92 T&A	2K/ammo box	645 gm/2K pcs	12.5" x 8" x 1.8"	2K	17" x 15" x 13.5"	32K	12.5 kgs

**TO-92
Plastic Package**

For Lead Free Parts, Device Part #
will be Prefixed with "T"

TO-92 Tape and Ammo Pack

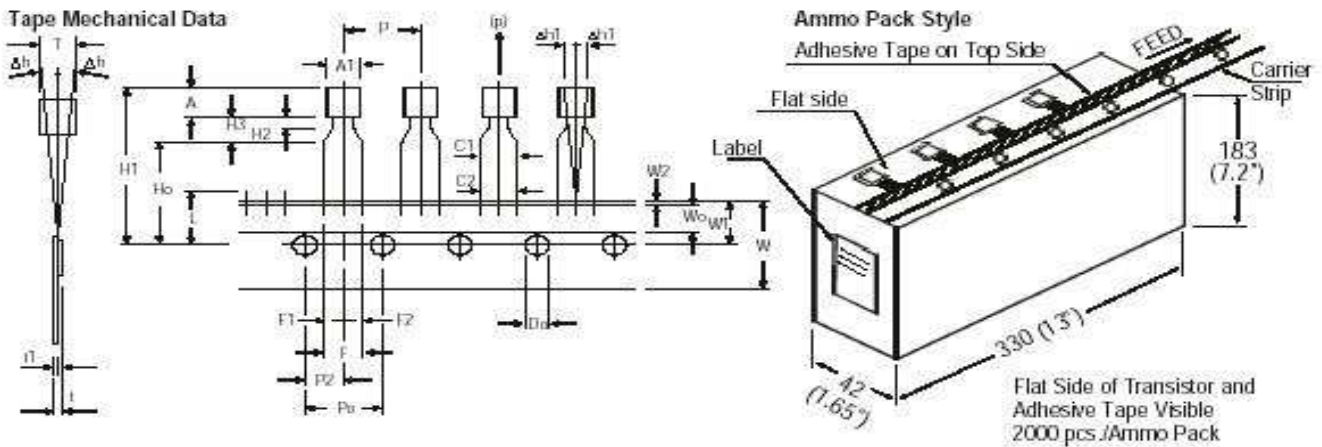

All dimensions are in mm

ITEM	SYMBOL	SPECIFICATION			
		MIN.	NOM.	MAX.	TOL.
BODY WIDTH	A1	4.45		5.20	
BODY HEIGHT	A	4.32		5.33	
BODY THICKNESS	T	3.18		4.19	
PITCH OF COMPONENT	P		12.7		± 1.0
*1 FEED HOLE PITCH	Po		12.7		± 0.3
*2 FEED HOLE CENTRE TO COMPONENT CENTRE	P2		6.35		± 0.4
DISTANCE BETWEEN OUTER LEADS	F		5.08		+ 0.6 - 0.2
*3 COMPONENT ALIGNMENT SIDE VIEW	Δh		0	1.0	
*4 COMPONENT ALIGNMENT FRONT VIEW	Δh1		0	1.3	
TAPE WIDTH	W		18		± 0.5
HOLD-DOWN TAPE WIDTH	Wo		6		± 0.2
HOLE POSITION	W1		9		+ 0.7 - 0.5
HOLD-DOWN TAPE POSITION	W2	0.0		0.7	
LEAD WIRE CLINCH HEIGHT	Ho		16		± 0.5
COMPONENT HEIGHT	H1			24.0	
LENGTH OF SNIPPED LEADS	L			11.0	
FEED HOLE DIAMETER	Do		4		± 0.2
*5 TOTAL TAPE THICKNESS	t			1.2	
LEAD - TO - LEAD DISTANCE	F1, F2	2.40		2.70	- 0.1
STAND OFF	H2	0.45		1.45	
CLINCH HEIGHT	H3			3.0	
LEAD PARALLELISM	C1 - C2			0.22	
PULL - OUT FORCE	(p)		6N		

NOTES

- Maximum alignment deviation between leads will not be greater than 0.2mm.
- Maximum non-cumulative variation between tape feed holes shall not exceed 1 mm in 20 pitches.
- Holddown tape will not exceed beyond the edge(s) of carrier tape and there shall be no exposure of adhesive.
- There will be no more than three (3) consecutive missing components in a tape.
- A tape trailer, having at least three feed holes are provided after the last component in a tape.
- Splices should not interfere with the sprocket feed holes.

REMARKS

- *1 Cumulative pitch error 1.0 mm/20 pitch
- *2 To be measured at bottom of clinch
- *3 At top of body
- *4 At top of body
- *5 t1 0.3 - 0.6 mm

Component Disposal Instructions

- CDIL Semiconductor Devices are RoHS compliant, customers are requested to please dispose as per prevailing Environmental Legislation of their Country.
- In Europe, please dispose as per EU Directive 2002/96/EC on Waste Electrical and Electronic Equipment (WEEE).

**TO-92
Plastic Package**

For Lead Free Parts, Device Part #
will be Prefixed with "T"

Disclaimer

The product information and the selection guides facilitate selection of the CDIL's Semiconductor Device(s) best suited for application in your product(s) as per your requirement. It is recommended that you completely review our Data Sheet(s) so as to confirm that the Device(s) meet functionality parameters for your application. The information furnished in the Data Sheet and on the CDIL Web Site/CD are believed to be accurate and reliable. CDIL however, does not assume responsibility for inaccuracies or incomplete information. Furthermore, CDIL does not assume liability whatsoever, arising out of the application or use of any CDIL product; neither does it convey any license under its patent rights nor rights of others. These products are not designed for use in life saving/support appliances or systems. CDIL customers selling these products (either as individual Semiconductor Devices or incorporated in their end products), in any life saving/support appliances or systems or applications do so at their own risk and CDIL will not be responsible for any damages resulting from such sale(s).

CDIL strives for continuous improvement and reserves the right to change the specifications of its products without prior notice.



CDIL is a registered Trademark of
Continental Device India Limited

C-120 Naraina Industrial Area, New Delhi 110 028, India.

Telephone + 91-11-2579 6150, 4141 1112, Fax + 91-11-2579 5290, 4141 1119

email@cdil.com www.cdilsemi.com