

NPN SILICON TRANSISTORS

2N6430, 6431

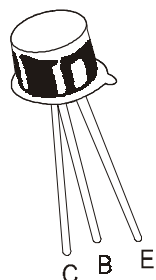

TO-18
Metal Can Package

General Purpose Transistors.

ABSOLUTE MAXIMUM RATINGS (Ta=25°C unless specified otherwise)

DESCRIPTION	SYMBOL	2N6430	2N6431	UNIT
Collector Emitter Voltage	V_{CEO}	200	300	V
Collector Base Voltage	V_{CBO}	200	300	V
Emitter Base Voltage	V_{EBO}		6	V
Collector Current Continuous	I_C		50	mA
Total Device Dissipation @Ta=25°C	P_D		500	mW
Derate Above 25°C			2.86	mW/°C
Total Device Dissipation @ Tc=25°C	P_D		1.8	W
Derate Above 25°C			10.3	mW/°C
Operating and Storage Junction Temperature Range	T_j, T_{stg}	-65 to +200		°C

ELECTRICAL CHARACTERISTICS (Ta=25°C unless specified otherwise)

DESCRIPTION	SYMBOL TEST CONDITION	VALUE			UNIT	
		MIN	TYP	MAX		
Collector Emitter Breakdown Voltage	$BV_{CEO}^* I_C=1.0mA, I_E=0$					
		2N6430	200			V
		2N6431	300			V
Collector Base Breakdown Voltage	$BV_{CBO} I_C=100\mu A, I_E=0$					
		2N6430	200			V
		2N6431	300			V
Emitter Base Breakdown Voltage	$BV_{EBO} I_E=100\mu A, I_C=0$		6.0			V
Collector Cut off Current	$I_{CBO} V_{CB}=160V, I_E=0$					
		2N6430			100	nA
		2N6431			100	nA
Emitter Cut off Current	$I_{EBO} V_{EB}=4V, I_C=0$					
					100	nA
DC Current Gain	$h_{FE} I_C=1mA, V_{CE}=10V$		25			
					40	
					50	

NPN SILICON TRANSISTORS

2N6430, 6431

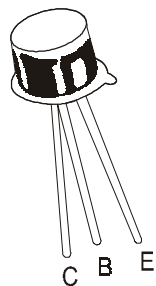

TO-18
Metal Can Package

ELECTRICAL CHARACTERISTICS (Ta=25°C unless specified otherwise)

DESCRIPTION	SYMBOL TEST CONDITION	VALUE			
		MIN	TYP	MAX	UNIT
Collector Emitter (sat) Voltage	$V_{CE(Sat)}$ $I_C=20mA, I_B=2.0mA$			0.5	V
Base Emitter (sat) Voltage	$V_{BE(Sat)}$ $I_C=20mA, I_B=2.0mA$			0.9	V

DYNAMIC CHARACTERISTICS

Current Gain Bandwidth Product	f_T $I_C=10mA, V_{CE}=20V$ $f=100MHz$	50		500	MHz
Output Capacitance	C_{cb} $V_{CB}=20V, I_E=0$ $f=1MHz$			4.0	pF

*Pulse Condition: Pulse Width =300 μ s, Duty Cycle =2%

**TO-18
Metal Can Package**

TO-18 Metal Can Package

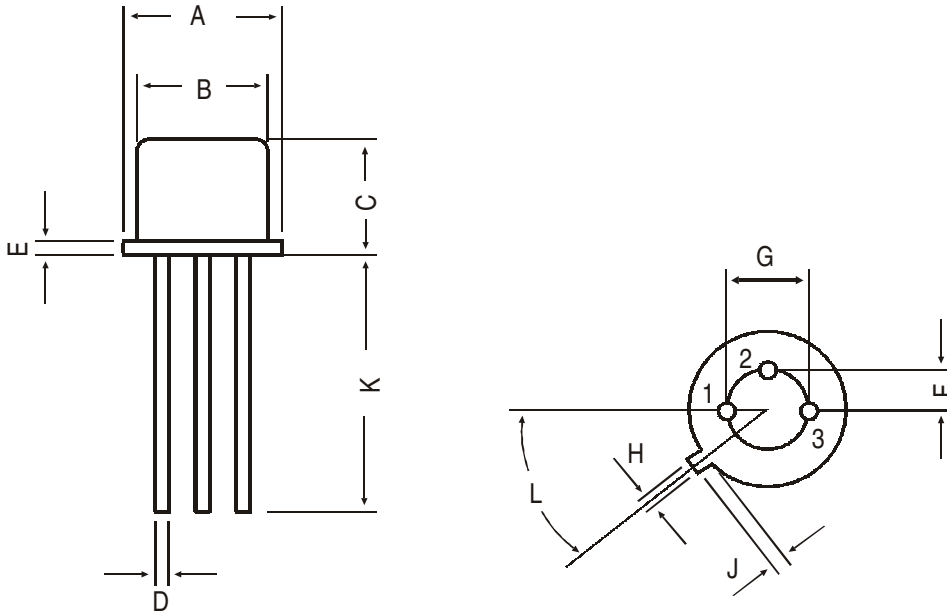

All dimensions in mm.

DIM	MIN	MAX
A	5.24	5.84
B	4.52	4.97
C	4.31	5.33
D	0.40	0.53
E	—	0.76
F	—	1.27
G	—	2.97
H	0.91	1.17
J	0.71	1.21
K	12.70	—
L	45 DEG	

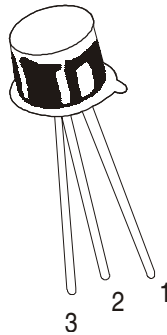

PIN CONFIGURATION

- 1. EMITTER
- 2. BASE
- 3. COLLECTOR

Packing Detail

PACKAGE	STANDARD PACK		INNER CARTON BOX		OUTER CARTON BOX		
	Details	Net Weight/Qty	Size	Qty	Size	Qty	Gr Wt
TO-18	1K/polybag	350 gm/1K pcs	3" x 7.5" x 7.5"	5K	17" x 15" x 13.5"	80K	34 kgs

Disclaimer

The product information and the selection guides facilitate selection of the CDIL's Discrete Semiconductor Device(s) best suited for application in your product(s) as per your requirement. It is recommended that you completely review our Data Sheet(s) so as to confirm that the Device(s) meet functionality parameters for your application. The information furnished in the Data Sheet and on the CDIL Web Site/CD is believed to be accurate and reliable. CDIL however, does not assume responsibility for inaccuracies or incomplete information. Furthermore, CDIL does not assume liability whatsoever, arising out of the application or use of any CDIL product; neither does it convey any license under its patent rights nor rights of others. These products are not designed for use in life saving/support appliances or systems. CDIL customers selling these products (either as individual Discrete Semiconductor Devices or incorporated in their end products), in any life saving/support appliances or systems or applications do so at their own risk and CDIL will not be responsible for any damages resulting from such sale(s).

CDIL strives for continuous improvement and reserves the right to change the specifications of its products without prior notice.



CDIL is a registered Trademark of

Continental Device India Limited

C-120 Naraina Industrial Area, New Delhi 110 028, India.

Telephone + 91-11-2579 6150, 5141 1112 Fax + 91-11-2579 5290, 5141 1119

email@cdil.com www.cdilsemi.com