

NPN SILICON PLANAR TRANSISTOR

2N3053 / 2N3053A

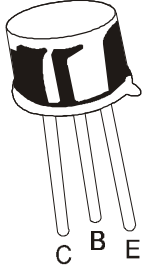

TO-39
Metal Can Package

General Purpose Transistors

ABSOLUTE MAXIMUM RATINGS

DESCRIPTION	SYMBOL	2N3053	2N3053A	UNIT
Collector Emitter Voltage	V_{CEO}	40	60	V
Collector Base Voltage	V_{CBO}	60	80	V
Emitter Base Voltage	V_{EBO}	5.0		V
Collector Current Continuous	I_C	0.7		A
Power Dissipation at $T_c=25^\circ\text{C}$ Derate Above 25°C	P_D	5.0	28.6	W mW/ $^\circ\text{C}$
Operating and Storage Junction Temperature Range	T_j, T_{stg}	- 65 to +200		$^\circ\text{C}$
Lead Temperature 1/16", \pm 1/32" from Case for 10s	T_L	+235		$^\circ\text{C}$

THERMAL RESISTANCE

Junction to Case	$R_{th(j-c)}$	35	$^\circ\text{C/W}$
------------------	---------------	----	--------------------

ELECTRICAL CHARACTERISTICS ($T_a=25^\circ\text{C}$ unless specified otherwise)

DESCRIPTION	SYMBOL	TEST CONDITION	2N3053	2N3053A	UNIT
Collector Emitter Voltage	V_{CEO}	$I_C=1\text{mA}, I_B=0$	>40	>60	V
Collector Emitter Voltage	V_{CER}	$I_C=1\text{mA}, R_{BE}=10\Omega$	>50	>70	V
Collector Base Voltage	V_{CBO}	$I_C=100\mu\text{A}, I_E=0$	>60	>80	V
Emitter Base Voltage	V_{EBO}	$I_E=100\mu\text{A}, I_C=0$	>5.0		V
Collector Cut Off Current	I_{CEX}	$V_{CE}=30\text{V}, I_E=0, V_{BE}(\text{off})=1.5\text{V}$	<250		nA
		$V_{CE}=60\text{V}, I_E=0, V_{BE}(\text{off})=1.5\text{V}$		<250	nA
Emitter Cut Off Current	I_{EBO}	$V_{EB}=4\text{V}, I_C=0$		<250	nA
Base Cut Off Current	I_{BL}	$V_{CE}=60\text{V}, I_E=0, V_{BE}(\text{off})=1.5\text{V}$		<250	nA
DC Current Gain	h_{FE}	$I_C=150\text{mA}, V_{CE}=2.5\text{V}$	>25		
		$I_C=150\text{mA}, V_{CE}=10\text{V}$	50 - 250		
Collector Emitter Saturation Voltage	$*V_{CE(sat)}$	$I_C=150\text{mA}, I_B=15\text{mA}$	<1.4	<0.3	V
Base Emitter Saturation Voltage	$*V_{BE(sat)}$	$I_C=150\text{mA}, I_B=15\text{mA}$	<1.7	0.6 - 1.0	V
Base Emitter On Voltage	$*V_{BE(on)}$	$I_C=150\text{mA}, V_{CE}=2.5\text{V}$	<1.7	<1.0	V

SMALL SIGNAL CHARACTERISTICS

Current Gain Bandwidth Product	f_T	$I_C=50\text{mA}, V_{CE}=10\text{V}, f=20\text{MHz}$	>100	MHz
Output Capacitance	C_{ob}	$V_{CB}=10\text{V}, I_E=0, f=140\text{KHz}$	<15	pF
Input Capacitance	C_{ib}	$V_{EB}=0.5\text{V}, I_C=0, f=140\text{KHz}$	<80	pF

*Pulse Test: Pulse Width $\leq 300\mu\text{s}$, Duty Cycle $\leq 2\%$

2N3053_A Rev_1 040406E

TO-39 Metal Can Package

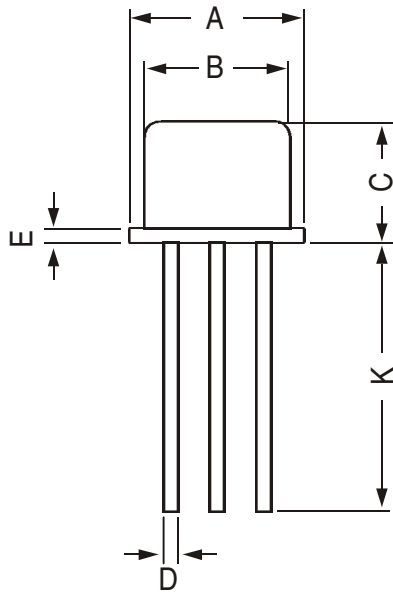

All dimensions are in mm

DIM	MIN	MAX
A	8.50	9.39
B	7.74	8.50
C	6.09	6.60
D	0.40	0.53
E	—	0.88
F	2.41	2.66
G	4.82	5.33
H	0.71	0.86
J	0.73	1.02
K	12.70	—
L	42 DEG	48 DEG

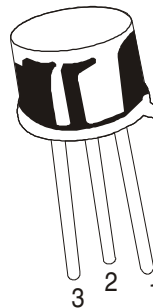
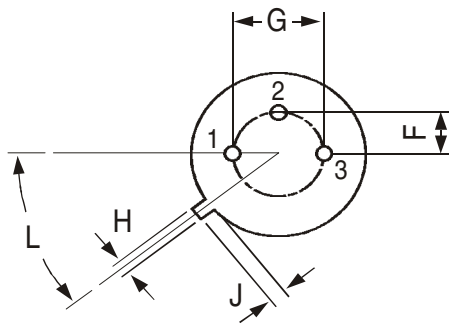

PIN CONFIGURATION

1. EMITTER
2. BASE
3. COLLECTOR

Packing Detail

PACKAGE	STANDARD PACK		INNER CARTON BOX		OUTER CARTON BOX		
	Details	Net Weight/ Qty	Size	Qty	Size	Qty	Gr Wt
TO-39	500 pcs/polybag	540 gm/500 pcs	3" x 7.5" x 7.5"	20K	17" x 15" x 13.5"	32K	40 kgs

Component Disposal Instructions

1. CDIL Semiconductor Devices are RoHS compliant, customers are requested to please dispose as per prevailing Environmental Legislation of their Country.
2. In Europe, please dispose as per EU Directive 2002/96/EC on Waste Electrical and Electronic Equipment (WEEE).

Disclaimer

The product information and the selection guides facilitate selection of the CDIL's Semiconductor Device(s) best suited for application in your product(s) as per your requirement. It is recommended that you completely review our Data Sheet(s) so as to confirm that the Device(s) meet functionality parameters for your application. The information furnished in the Data Sheet and on the CDIL Web Site/CD are believed to be accurate and reliable. CDIL however, does not assume responsibility for inaccuracies or incomplete information. Furthermore, CDIL does not assume liability whatsoever, arising out of the application or use of any CDIL product; neither does it convey any license under its patent rights nor rights of others. These products are not designed for use in life saving/support appliances or systems. CDIL customers selling these products (either as individual Semiconductor Devices or incorporated in their end products), in any life saving/support appliances or systems or applications do so at their own risk and CDIL will not be responsible for any damages resulting from such sale(s).

CDIL strives for continuous improvement and reserves the right to change the specifications of its products without prior notice.



CDIL is a registered Trademark of
Continental Device India Limited

C-120 Naraina Industrial Area, New Delhi 110 028, India.

Telephone + 91-11-2579 6150, 4141 1112 Fax + 91-11-2579 5290, 4141 1119

email@cdil.com www.cdilsemi.com