

NPN SILICON PLANAR EPITAXIAL TRANSISTORS

2N2369
2N2369A
TO-18

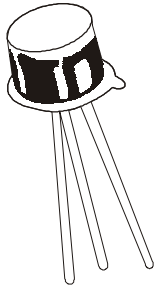

APPLICATIONS

2N2369/A are NPN Silicon High Speed Saturated Switching, Transistors With Low Power & High Speed Switching Applications.

ABSOLUTE MAXIMUM RATINGS

DESCRIPTION	SYMBOL	VALUE	UNIT
Collector -Emitter Voltage	VCEO	15	V
Collector -Emitter Voltage	VCES	40	V
Collector -Base Voltage	VCBO	40	V
Emitter -Base Voltage	VEBO	4.5	V
Collector Current Continuous	IC	200	mA
Collector Current Peak(10us pulse)	IC(peak)	500	mA
Power Dissipation@ Ta=25 degC	PD	360	mW
Derate Above 25 deg C		2.06	mW/deg C
@Tc=25 deg C	PD	1.2	W
@Tc=100 deg C	PD	0.68	W
Derate Above100 deg C		6.85	mW/deg C
Operating And Storage Junction Temperature Range	Tj, Tstg	-65 to +200	deg C

ELECTRICAL CHARACTERISTICS (Ta=25 deg C Unless Otherwise Specified)

DESCRIPTION	SYMBOL	TEST CONDITION	2N2369	2N2369A	UNIT
Collector -Emitter Voltage	VCEO*(sus)	IC=10mA, IB=0	>15	>15	V
Collector -Emitter Voltage	VCES	IC=10uA, VBE=0	>40	>40	V
Collector -Base Voltage	VCBO	IC=10uA, IE=0	>40	>40	V
Emitter -Base Voltage	VEBO	IE=10uA, IC=0	>4.5	>4.5	V
Collector-Cut off Current	ICBO	VCB=20V, IE=0	<400	-	nA
		VCB=20V, IE=0, Ta=150 deg C	<30	-	uA
	ICES	VCE=20V, VBE=0	-	<400	nA
Base Current	IB	VCE=20V, VBE=0	-	<400	nA
Collector Emitter Saturation Voltage	VCE(Sat)*	IC=10mA, IB=1mA	<0.25	<0.20	V
		IC=30mA, IB=3mA	-	<0.25	V
		IC=100mA, IB=10mA	-	<0.50	V
		IC=10mA, IB=1mA, Ta= +125 deg C	-	<0.30	V
Base Emitter Saturation Voltage	VBE(Sat) *	IC=10mA, IB=1mA	0.7-0.85	0.7-0.85	V
		IC=30mA, IB=3mA	-	<1.15	V
		IC=100mA, IB=10mA	-	<1.60	V
		IC=10mA, IB=1mA, Ta= +125 deg C	-	>0.59	V
		IC=10mA, IB=1mA, Ta= -55 deg C	-	<1.02	V
DC Current	hFE*	IC=10mA, VCE=1V	40-120	40-120	
		IC=10mA, VCE=1V, Ta= -55 deg C	>20	-	
		IC=10mA, VCE=0.35V, Ta= -55 deg C	-	>20	

ELECTRICAL CHARACTERISTICS (Ta=25 deg C Unless Otherwise Specified)

2N2369/2369A

DESCRIPTION	SYMBOL	TEST CONDITION	2N2369	2N2369A	UNIT
DC Current	hFE*	IC=10mA, VCE=0.35V	-	40-120	
		IC=30mA, VCE=0.4V	-	>30	
		IC=100mA, VCE=1V	-	>20	
		IC=100mA, VCE=2V	>20	-	
Small Signal Characteristics					
Transition Frequency	ft	VCE=10V, IC=10mA, f=100MHz	>500	>500	MHZ
Output Capacitance	Cobo	VCB=5V, IE=0, f=140kHz	<4.0	<4.0	pF
Turn on Time	ton	IC=10mA, IB1=3mA, IB= -1.5mA, VCC=3V	<12	<12	ns
Turn off Time	toff	IC=10mA, IB1=3mA, IB2= -1.5mA, VCC=3V	-	<15	ns
Storage Time	ts	IC=100mA, IB1=IB=10mA, VCC=10V	<13	<13	ns

*Pulse Test : Pulse Width =300us, Duty Cycle=2%

TO-18 Metal Can Package

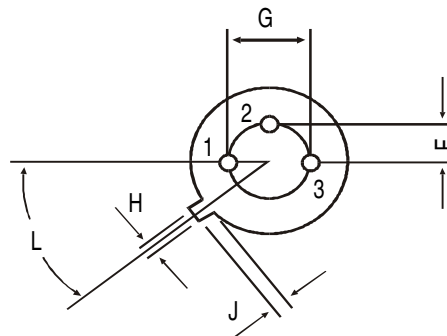
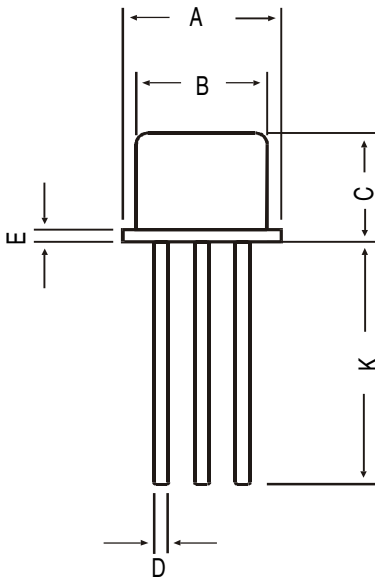

All dimensions in mm.

DIM	MIN	MAX
A	5.24	5.84
B	4.52	4.97
C	4.31	5.33
D	0.40	0.53
E	—	0.76
F	—	1.27
G	—	2.97
H	0.91	1.17
J	0.71	1.21
K	12.70	—
L	45 DEG	

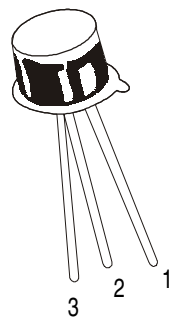

PIN CONFIGURATION

1. EMITTER
2. BASE
3. COLLECTOR

Packing Detail

PACKAGE	STANDARD PACK		INNER CARTON BOX		OUTER CARTON BOX		
	Details	Net Weight/Qty	Size	Qty	Size	Qty	Gr Wt
TO-18	1K/polybag	350 gm/1K pcs	3" x 7.5" x 7.5"	5.0K	17" x 15" x 13.5"	80.0K	34 kgs

Notes

Disclaimer

The product information and the selection guides facilitate selection of the CDIL's Discrete Semiconductor Device(s) best suited for application in your product(s) as per your requirement. It is recommended that you completely review our Data Sheet(s) so as to confirm that the Device(s) meet functionality parameters for your application. The information furnished on the CDIL Web Site/CD is believed to be accurate and reliable. CDIL however, does not assume responsibility for inaccuracies or incomplete information. Furthermore, CDIL does not assume liability whatsoever, arising out of the application or use of any CDIL product; neither does it convey any license under its patent rights nor rights of others. These products are not designed for use in life saving/support appliances or systems. CDIL customers selling these products (either as individual Discrete Semiconductor Devices or incorporated in their end products), in any life saving/support appliances or systems or applications do so at their own risk and CDIL will not be responsible for any damages resulting from such sale(s).

CDIL strives for continuous improvement and reserves the right to change the specifications of its products without prior notice.



CDIL is a registered Trademark of

Continental Device India Limited

C-120 Naraina Industrial Area, New Delhi 110 028, India.

Telephone + 91-11-2579 6150, 5141 1112 Fax + 91-11-2579 5290, 5141 1119

email@cdil.com www.cdilsemi.com