

**SOT-23 Formed SMD Package**

**CMBTA05  
 CMBTA06**

**SILICON EPITAXIAL TRANSISTORS**

*N-P-N transistor*

**Marking**

CMBTA05 = 1H  
 CMBTA06 = 1G

**PACKAGE OUTLINE DETAILS  
 ALL DIMENSIONS IN mm**

**Pin configuration**

1 = BASE  
 2 = EMITTER  
 3 = COLLECTOR

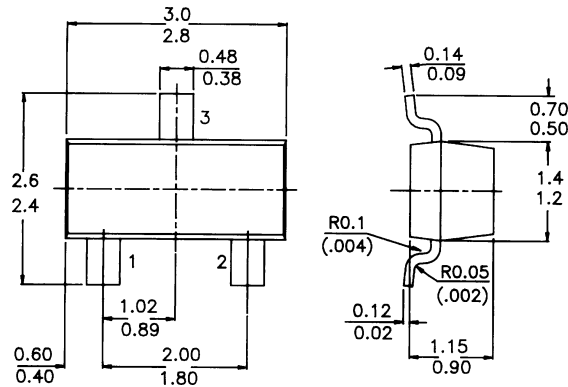
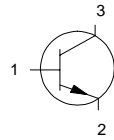

**ABSOLUTE MAXIMUM RATINGS**

		<b>CMBTA05</b>	<b>A06</b>
Collector-base voltage (open emitter)	$V_{CB0}$	max. 60	80 V
Collector-emitter voltage (open base)	$V_{CE0}$	max. 60	80 V
Emitter-base voltage (open collector)	$V_{EBO}$	max. 4	V
Collector current (d.c.)	$I_C$	max. 500	mA
Total power dissipation up to $T_{amb} = 25\text{ }^\circ\text{C}$	$P_{tot}$	max. 250	mW
D.C. current gain			
$I_C = 100\text{ mA}; V_{CE} = 1\text{ V}$	$h_{FE}$	min. 100	
Transition frequency at $f = 100\text{ MHz}$			
$I_C = 10\text{ mA}; V_{CE} = 2\text{ V}$	$f_T$	min. 100	MHz
Collector-emitter saturation voltage			
$I_C = 100\text{ mA}; I_B = 10\text{ mA}$	$V_{CEsat}$	max. 0.25	V

**CMBTA05**  
**CMBTA06**

**RATINGS** (at  $T_A = 25^\circ\text{C}$  unless otherwise specified)

Limiting values

Collector-base voltage (open emitter)	$V_{CB0}$	max.	60		80	V
Collector-emitter voltage (open base)	$V_{CE0}$	max.	60		80	V
Emitter-base voltage (open collector)	$V_{EB0}$	max.	4			V
Collector current (d.c.)	$I_C$	max.	500			mA
Total power dissipation up to $T_{amb} = 25^\circ\text{C}$	$P_{tot}$	max.	250			mW
Storage temperature	$T_{stg}$	max.	-55 to +150			$^\circ\text{C}$
Junction temperature	$T_j$	max.	150			$^\circ\text{C}$

**THERMAL CHARACTERISTICS**

$$T_j = P (R_{th\ j-t} + R_{th\ t-s} + R_{th\ s-a}) + T_{amb}$$

Thermal resistance

from junction to ambient  $R_{th\ j-a} = 500\ \text{K/W}$

**CHARACTERISTICS** (at  $T_A = 25^\circ\text{C}$  unless otherwise specified)

			<b>CMBTA05</b>		<b>A06</b>	
Collector-emitter breakdown voltage						
$I_C = 1\ \text{mA}; I_B = 0$	$V_{(BR)CEO}$	min.	60		80	V
Emitter-base breakdown voltage						
$I_C = 0; I_E = 100\ \mu\text{A}$	$V_{(BR)EBO}$	min.	4			V
Collector cut-off current						
$V_{CE} = 60\ \text{V}; I_B = 0$	$I_{CEO}$	max.	0.1			$\mu\text{A}$
$V_{CB} = 60\ \text{V}; I_E = 0$	$I_{CBO}$	max.	0.1			$\mu\text{A}$
$V_{CB} = 80\ \text{V}; I_E = 0$	$I_{CBO}$	max.			0.1	$\mu\text{A}$
Saturation voltages						
$I_C = 100\ \text{mA}; I_B = 10\ \text{mA}$	$V_{CEsat}$	max.	0.25			V
Base-emitter on voltage						
$I_C = 100\ \text{mA}; V_{CE} = 1\ \text{V}$	$V_{BE(on)}$	max.	1.2			V
D.C. current gain						
$I_C = 10\ \text{mA}; V_{CE} = 1\ \text{V}$	$h_{FE}$	min.	100			
$I_C = 100\ \text{mA}; V_{CE} = 1\ \text{V}$	$h_{FE}$	min.	100			
Transition frequency at $f = 100\ \text{MHz}$						
$I_C = 10\ \text{mA}; V_{CE} = 2\ \text{V}$	$f_T$	min.	100			MHz

## Disclaimer

The product information and the selection guides facilitate selection of the CDIL's Discrete Semiconductor Device(s) best suited for application in your product(s) as per your requirement. It is recommended that you completely review our Data Sheet(s) so as to confirm that the Device(s) meet functionality parameters for your application. The information furnished on the CDIL Web Site/ CD are believed to be accurate and reliable. CDIL however, does not assume responsibility for inaccuracies or incomplete information. Furthermore, CDIL does not assume liability whatsoever, arising out of the application or use of any CDIL product; neither does it convey any license under its patent rights nor rights of others. These products are not designed for use in life saving/support appliances or systems. CDIL customers selling these products (either as individual Discrete Semiconductor Devices or incorporated in their end products), in any life saving/support appliances or systems or applications do so at their own risk and CDIL will not be responsible for any damages resulting from such sale(s).

CDIL strives for continuous improvement and reserves the right to change the specifications of its products without prior notice.



CDIL is a registered Trademark of  
**Continental Device India Limited**

C-120 Naraina Industrial Area, New Delhi 110 028, India.  
Telephone + 91-11-2579 6150, 5141 1112 Fax + 91-11-2579 5290, 5141 1119  
email@cdil.com www.cdilsemi.com