

**PNP EPITAXIAL PLANAR SILICON TRANSISTOR**

**CMBT200  
CMBT200A  
SOT23**

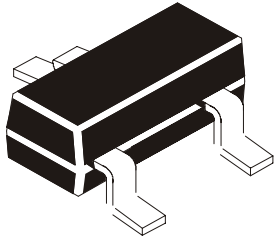

**PIN CONFIGURATION (PNP)**

- 1 = BASE
- 2 = EMITTER
- 3 = COLLECTOR

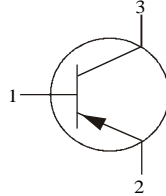

**MARKING : AS BELOW**

Designed for General Purpose Amplifier Applications.

**ABSOLUTE MAXIMUM RATINGS(Ta=25deg C unless otherwise noted)**

DESCRIPTION	SYMBOL	VALUE	UNIT
Collector -Base Voltage	VCBO	60	V
Collector -Emitter Voltage	VCEO	45	V
Emitter Base Voltage	VEBO	6.0	V
Collector Current - Continuous	IC	500	mA
Power Dissipation	PD	350	mW
Derate Above=25 deg C		2.8	mW/de g C
Operating And Storage Junction Temperature Range	Tj, Tstg	-55 to +150	deg C
<u>Thermal Resistance</u>			
Junction to Ambient	(Rth j-a)	357	deg C/W

**ELECTRICAL CHARACTERISTICS (Ta=25 deg C Unless Otherwise Noted)**

DESCRIPTION	SYMBOL	TEST CONDITION	MIN	MAX	UNIT
Collector -Base Voltage	VCBO	IC=10uA, IE=0	60	-	V
Collector -Emitter Voltage	VCEO	IC=1mA, IB=0	45	-	V
Emitter Base Voltage	VEBO	IE=10uA, IC=0	6.0	-	V
Collector Cut off Current	ICBO	VCB=50V, IE=0	-	50	nA
	ICES	VCE=4V, IE=0	-	50	nA
Emitter Cut off Current	IEBO	VEB=4V, IC=0	-	50	nA
DC Current Gain	hFE	IC=100uA,VCE=1V	CMBT200	80	-
			CMBT200A	240	-
	IC=10mA,VCE=1V	CMBT200	100	450	
		CMBT200A	300	600	
	IC=100mA,VCE=1V*	CMBT200A	100	-	
		IC=150mA,VCE=5V*	CMBT200	100	350
	CMBT200A	100	-		

**ELECTRICAL CHARACTERISTICS (Ta=25 deg C Unless Otherwise Noted)**

**CMBT200, A**

DESCRIPTION	SYMBOL	TEST CONDITION	MIN	MAX	UNIT	
<b>Collector Emitter Saturation Voltage</b>	VCE(Sat)	IC=10mA, IB=1mA	-	0.2	V	
		IC=200mA, IB=20mA*	-	0.4	V	
<b>Base Emitter Saturation Voltage</b>	VBE(Sat)	IC=10mA, VCE=1V	-	0.85	V	
		IC=200mA, IB=20mA*	-	1.0	V	
<b><u>Dynamic Characteristics</u></b>						
<b>Transition Frequency</b>	ft	VCE=20V, IC=20mA,	250	-	MHz	
<b>Output Capacitance</b>	Cobo	VCB=10V, f=1MHz	-	6.0	pF	
<b>Noise Figure</b>	NF	IC=100uA, VCE=5V	CMBT200	-	5.0	dB
		Rg=2 Kohms, f=1.0 kHz	CMBT200A	-	4.0	dB
<b>DEVICE</b>		CMBT200	CMBT200A			
<b>MARKING</b>		<b>N2</b>	<b>N2A</b>			
<b>*Pulse test : Pulse Width =300us, duty cycle=2%</b>						

**SOT-23 Formed SMD Package**

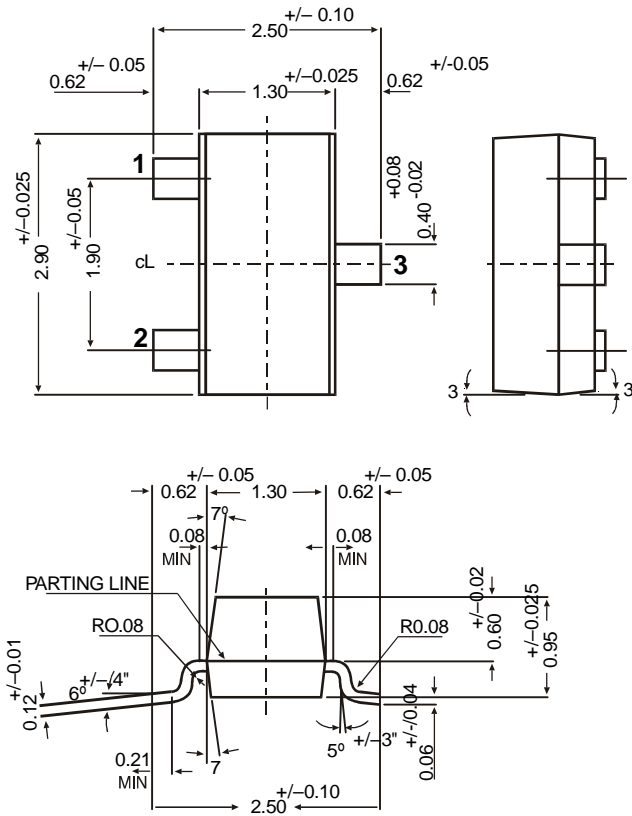

**SOT-23 Package Reel Information  
Reel specifications for Packing (13"/7" reels)**

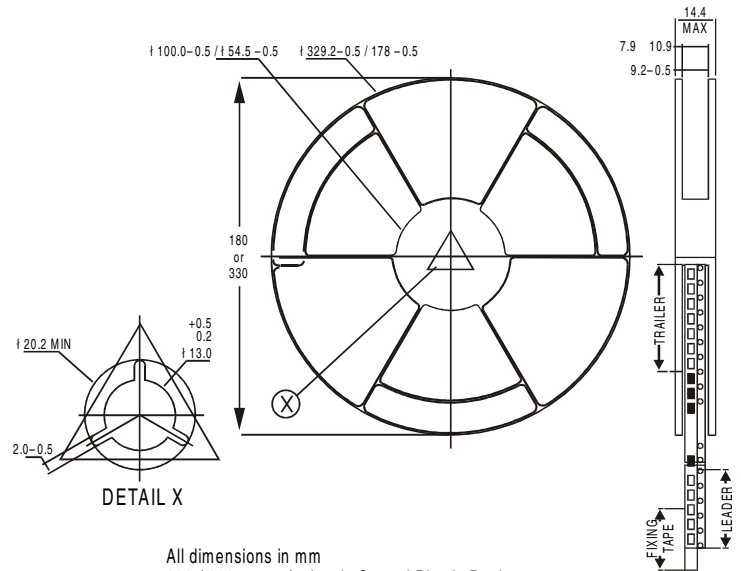

All dimensions in mm  
330 / 180 mm Antistatic Coated Plastic Reel

**NOTES:**

No. of Devices	8mm Tape Size of Reel	8mm Tape Size of Reel
10,000 Pcs	330 mm (13")	180 mm (7")
3,000 Pcs		3,000 Pcs

1. The bandolier of 330 mm reel contains at least 10,000 devices.
2. The bandolier of 180 mm reel contains at least 3,000 devices.
3. No more than 0.5% missing devices / reel. 50 empty compartments for 330 mm reel. 15 empty compartments for 180 mm reel.
4. Three consecutive empty places might be found provided this gap is followed by 6 consecutive devices.
5. The carrier tape (leader) starts with at least 75 empty positions (equivalent to 330 mm). In order to fix the carrier tape a self adhesive tape of 20 to 50 mm is applied. At the end of the bandolier at least 40 empty positions (equivalent to 160 mm) are there.

**Tape Specification for SOT-23 Surface Mount Device**

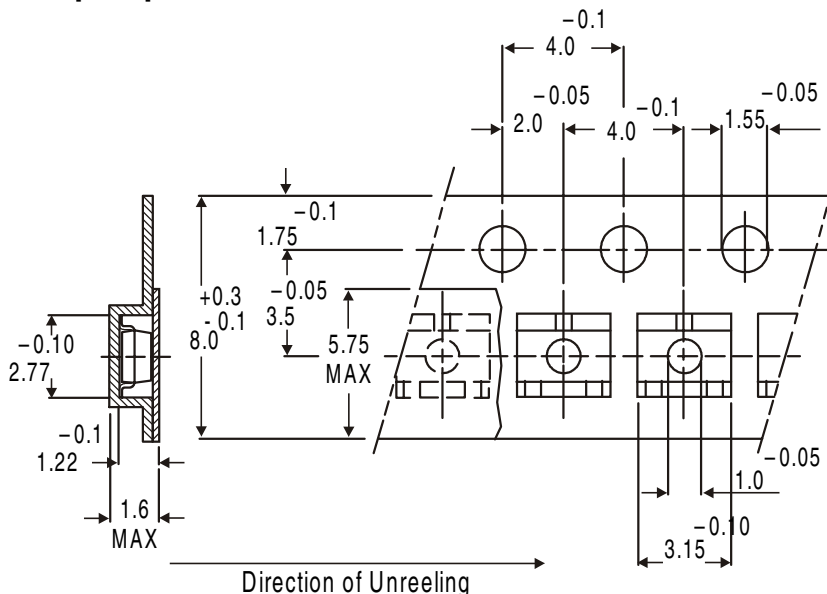

All dimensions in mm

## Packing Detail

PACKAGE	STANDARD PACK		INNER CARTON BOX		OUTER CARTON BOX		
	Details	Net Weight/Qty	Size	Qty	Size	Qty	Gr Wt
SOT-23 T&R	3K/reel	136 gm/3K pcs	3" x 7.5" x 7.5"	12.0K	17" x 15" x 13.5"	192.0K	12 kgs
			9" x 9" x 9"	51.0K	19" x 19" x 19"	408.0K	28 kgs
	10K/reel	415 gm/10K pcs	13" x 13" x 0.5"	10.0K	17" x 15" x 13.5"	300.0K	16 kgs

## Customer Notes

### Component Disposal Instructions

1. CDIL Semiconductor Devices are RoHS compliant, customers are requested to please dispose as per prevailing Environmental Legislation of their Country.
2. In Europe, please dispose as per EU Directive 2002/96/EC on Waste Electrical and Electronic Equipment (WEEE).

## Disclaimer

The product information and the selection guides facilitate selection of the CDIL's Discrete Semiconductor Device(s) best suited for application in your product(s) as per your requirement. It is recommended that you completely review our Data Sheet(s) so as to confirm that the Device(s) meet functionality parameters for your application. The information furnished on the CDIL Web Site/CD are believed to be accurate and reliable. CDIL however, does not assume responsibility for inaccuracies or incomplete information. Furthermore, CDIL does not assume liability whatsoever, arising out of the application or use of any CDIL product; neither does it convey any license under its patent rights nor rights of others. These products are not designed for use in life saving/support appliances or systems. CDIL customers selling these products (either as individual Discrete Semiconductor Devices or incorporated in their end products), in any life saving/support appliances or systems or applications do so at their own risk and CDIL will not be responsible for any damages resulting from such sale(s).

CDIL strives for continuous improvement and reserves the right to change the specifications of its products without prior notice.



CDIL is a registered Trademark of  
Continental Device India Limited

C-120 Naraina Industrial Area, New Delhi 110 028, India.

Telephone + 91-11-2579 6150, 4141 1112 Fax + 91-11-2579 5290, 4141 1119

email@cdil.com www.cdilsemi.com