

NPN SILICON PLANAR TRANSISTOR

2N2102

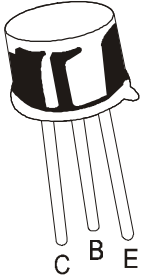

TO-39
Metal Can Package

Amplifier Transistor

ABSOLUTE MAXIMUM RATINGS

DESCRIPTION	SYMBOL	VALUE	UNIT
Collector Emitter Voltage	V_{CEO}	65	V
Collector Emitter Voltage, $R_{BE} \leq 10\Omega$	V_{CER}	80	V
Collector Base Voltage	V_{CBO}	120	V
Emitter Base Voltage	V_{EBO}	7.0	V
Collector Current Continuous	I_C	1.0	A
Power Dissipation @ $T_a=25^\circ\text{C}$ Derate Above 25°C	P_D	1.0 5.71	mW mW/ $^\circ\text{C}$
Power Dissipation @ $T_c=25^\circ\text{C}$ Derate Above 25°C	P_D	5.0 28.6	W mW/ $^\circ\text{C}$
Operating and Storage Junction Temperature Range	T_j, T_{stg}	- 65 to +200	$^\circ\text{C}$

THERMAL RESISTANCE

Junction to Ambient in free air	$R_{th(j-a)}$	175	$^\circ\text{C/W}$
Junction to Case	$R_{th(j-c)}$	35	$^\circ\text{C/W}$

ELECTRICAL CHARACTERISTICS ($T_a=25^\circ\text{C}$ unless specified otherwise)

DESCRIPTION	SYMBOL	TEST CONDITION	MIN	TYP	MAX	UNIT
Collector Emitter Voltage	V_{CER}	$I_C=1\text{mA}, R_{BE}=10\Omega$	80			V
Collector Emitter Voltage	V_{CEO}	$I_C=1\text{mA}, I_B=0$	65			V
Collector Emitter Voltage	V_{CEX}	$I_C=100\mu\text{A}, V_{EB}=1.5\text{V}$	120			V
Collector Base Voltage	V_{CBO}	$I_C=100\mu\text{A}, I_E=0$	120			V
Emitter Base Voltage	V_{EBO}	$I_E=100\mu\text{A}, I_C=0$	7			V
Collector Cut Off Current	I_{CBO}	$V_{CB}=60\text{V}, I_E=0$			2	nA
		$V_{CB}=60\text{V}, I_E=0, T_a=150^\circ\text{C}$			2	μA
Emitter Cut Off Current	I_{EBO}	$V_{EB}=5\text{V}, I_C=0$			2	nA
DC Current Gain	h_{FE}	$I_C=0.1\text{mA}, V_{CE}=10\text{V}$	20			
		$*I_C=10\text{mA}, V_{CE}=10\text{V}$	35			
		$*I_C=10\text{mA}, V_{CE}=10\text{V}, T_a=55^\circ\text{C}$	20			
		$*I_C=150\text{mA}, V_{CE}=10\text{V}$	40		120	
		$*I_C=500\text{mA}, V_{CE}=10\text{V}$	25			
		$*I_C=1\text{A}, V_{CE}=10\text{V}$	10			

*Pulse Test: Pulse Width $\leq 300\mu\text{s}$, Duty Cycle $\leq 2\%$

** $R_{th(j-a)}$ is measured with the device soldered into a typical printed circuit board

2N2102Rev_1 040904E

NPN SILICON PLANAR TRANSISTOR

2N2102

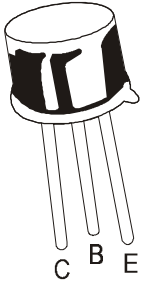

TO-39
Metal Can Package

ELECTRICAL CHARACTERISTICS ($T_a=25^\circ\text{C}$ unless specified otherwise)

DESCRIPTION	SYMBOL	TEST CONDITION	MIN	TYP	MAX	UNIT
Collector Emitter Saturation Voltage	$*V_{CE(sat)}$	$I_C=150\text{mA}, I_B=15\text{mA}$			0.5	V
Base Emitter Saturation Voltage	$*V_{BE(sat)}$	$I_C=150\text{mA}, I_B=15\text{mA}$			1.1	V

SMALL SIGNAL CHARACTERISTICS

Transition Frequency	f_T	$I_C=50\text{mA}, V_{CE}=10\text{V}, f=20\text{MHz}$	60			MHz
Output Capacitance	C_{obo}	$V_{CB}=10\text{V}, I_E=0, f=1\text{MHz}$			15	pF
Input Capacitance	C_{ibo}	$V_{EB}=0.5\text{V}, I_C=0, f=1\text{MHz}$			80	pF
Input Impedance	h_{ib}	$I_C=1\text{mA}, V_{CE}=5\text{V}, f=1\text{KHz}$	24		34	Ω
		$I_C=5\text{mA}, V_{CE}=10\text{V}, f=1\text{KHz}$	4.0		8.0	Ω
Voltage Feedback Ratio	h_{rb}	$I_C=1\text{mA}, V_{CE}=5\text{V}, f=1\text{KHz}$			3.0	$\times 10^{-4}$
		$I_C=5\text{mA}, V_{CE}=10\text{V}, f=1\text{KHz}$			3.0	$\times 10^{-4}$
Small Signal Current Gain	h_{fe}	$I_C=1\text{mA}, V_{CE}=5\text{V}, f=1\text{KHz}$	30		100	
		$I_C=5\text{mA}, V_{CE}=10\text{V}, f=1\text{KHz}$	35		150	
Output Impedance	h_{ob}	$I_C=1\text{mA}, V_{CE}=5\text{V}, f=1\text{KHz}$	0.01		0.5	μmho
		$I_C=5\text{mA}, V_{CE}=10\text{V}, f=1\text{KHz}$	0.01		1.0	μmho
Noise Figure	NF	$I_C=300\mu\text{A}, V_{CE}=10\text{V},$ $f=1\text{KHz}, \text{Bandwidth}=1.0\text{ Hz}$ $R_S=1\text{k}\Omega$			6.0	dB

2N2102Rev_1 040904E

TO-39 Metal Can Package

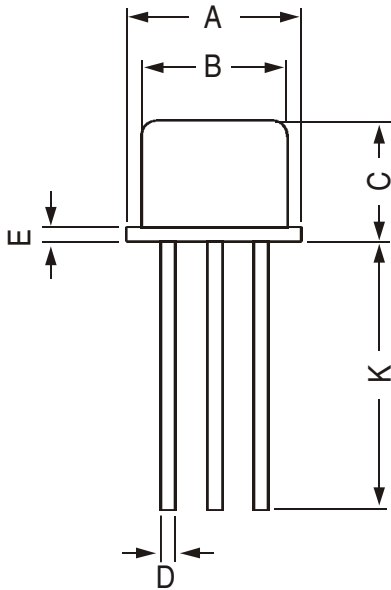

All dimensions are in mm

DIM	MIN	MAX
A	8.50	9.39
B	7.74	8.50
C	6.09	6.60
D	0.40	0.53
E	—	0.88
F	2.41	2.66
G	4.82	5.33
H	0.71	0.86
J	0.73	1.02
K	12.70	—
L	42 DEG	48 DEG

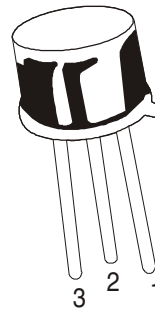
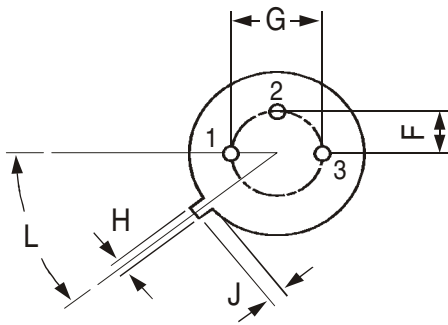

PIN CONFIGURATION

- 1. EMITTER
- 2. BASE
- 3. COLLECTOR

Packing Detail

PACKAGE	STANDARD PACK		INNER CARTON BOX		OUTER CARTON BOX		
	Details	Net Weight/ Qty	Size	Qty	Size	Qty	Gr Wt
TO-39	500 pcs/polybag	540 gm/500 pcs	3" x 7.5" x 7.5"	20K	17" x 15" x 13.5"	32K	40 kgs

Disclaimer

The product information and the selection guides facilitate selection of the CDIL's Discrete Semiconductor Device(s) best suited for application in your product(s) as per your requirement. It is recommended that you completely review our Data Sheet(s) so as to confirm that the Device(s) meet functionality parameters for your application. The information furnished in the Data Sheet and on the CDIL Web Site/CD are believed to be accurate and reliable. CDIL however, does not assume responsibility for inaccuracies or incomplete information. Furthermore, CDIL does not assume liability whatsoever, arising out of the application or use of any CDIL product; neither does it convey any license under its patent rights nor rights of others. These products are not designed for use in life saving/support appliances or systems. CDIL customers selling these products (either as individual Discrete Semiconductor Devices or incorporated in their end products), in any life saving/support appliances or systems or applications do so at their own risk and CDIL will not be responsible for any damages resulting from such sale(s).

CDIL strives for continuous improvement and reserves the right to change the specifications of its products without prior notice.



CDIL is a registered Trademark of
Continental Device India Limited

C-120 Naraina Industrial Area, New Delhi 110 028, India.

Telephone + 91-11-2579 6150, 5141 1112 Fax + 91-11-2579 5290, 5141 1119

email@cdil.com www.cdilsemi.com