

**NPN SILICON PLANAR EPITAXIAL TRANSISTOR**

**CMBTA44**

**SOT-23  
Formed SMD Package**

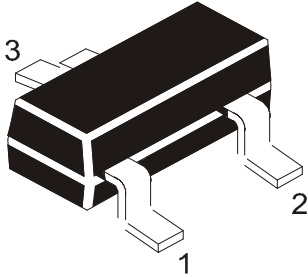

**PIN CONFIGURATION (NPN)**

- 1 = BASE
- 2 = EMITTER
- 3 = COLLECTOR

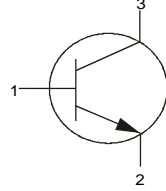

**Marking Code is =3Z**

**Designed for Extremely High Voltage Applications**

**ABSOLUTE MAXIMUM RATINGS (T<sub>a</sub>=25°C)**

DESCRIPTION	SYMBOL	VALUE	UNITS
Collector Base Voltage	V <sub>CBO</sub>	450	V
Collector Emitter Voltage	V <sub>CEO</sub>	400	V
Emitter Base Voltage	V <sub>EBO</sub>	6	V
Collector Current	I <sub>C</sub>	300	mA
Collector Power Dissipation	P <sub>D</sub>	350	mW
Operating And Storage Junction Temperature Range	T <sub>j</sub> , T <sub>stg</sub>	- 65 to +150	°C

**THERMAL RESISTANCE**

Junction to Ambient in free air	R <sub>th(j-a)</sub>	357	°C/W
---------------------------------	----------------------	-----	------

**Electrical Characteristics (T<sub>a</sub>=25°C unless specified otherwise)**

DESCRIPTION	SYMBOL	CONDITIONS	MIN	TYP	MAX	UNIT
Collector Cut Off Current	I <sub>CBO</sub>	V <sub>CB</sub> =400V, I <sub>E</sub> =0			100	nA
Collector Cut Off Current	I <sub>CES</sub>	V <sub>CE</sub> =400V, V <sub>BE</sub> =0			500	nA
Emitter Cut Off Current	I <sub>EBO</sub>	V <sub>EB</sub> =4V, I <sub>C</sub> =0			100	nA
Collector Base Voltage	V <sub>CBO</sub>	I <sub>C</sub> =100μA, I <sub>E</sub> =0	450			V
Collector Emitter Voltage	V <sub>CES</sub>	I <sub>C</sub> =100μA, V <sub>BE</sub> =0	450			V
Collector Emitter Voltage	V <sub>CEO</sub>	I <sub>C</sub> =1mA, I <sub>B</sub> =0	400			V
Emitter Base Voltage	V <sub>EBO</sub>	I <sub>E</sub> =10μA, I <sub>C</sub> =0	6			V
Collector Emitter Saturation Voltage	V <sub>CE(sat)</sub>	I <sub>C</sub> =1mA, I <sub>B</sub> =0.1mA			0.40	V
		I <sub>C</sub> =10mA, I <sub>B</sub> =1mA			0.50	V
		I <sub>C</sub> =50mA, I <sub>B</sub> =5mA			0.75	V
Base Emitter Saturation Voltage	V <sub>BE(sat)</sub>	I <sub>C</sub> =10mA, I <sub>B</sub> =1mA			0.75	V
DC Current Gain	h <sub>FE</sub>	V <sub>CE</sub> =10V, I <sub>C</sub> =1mA	40		200	
		V <sub>CE</sub> =10V, I <sub>C</sub> =10mA	50			
		V <sub>CE</sub> =10V, I <sub>C</sub> =50mA	45			
		V <sub>CE</sub> =10V, I <sub>C</sub> =100mA	20			
Transition Frequency	f <sub>T</sub>	V <sub>CE</sub> =10V, I <sub>C</sub> =10mA, f=10MHz	20			MHz
Output Capacitance	C <sub>ob</sub>	V <sub>CB</sub> =20V, I <sub>E</sub> =0, f=1MHz			7.0	pF
Input Capacitance	C <sub>ib</sub>	V <sub>EB</sub> =0.5V, I <sub>C</sub> =0, f=1MHz			130	pF

SOT-23 Formed SMD Package

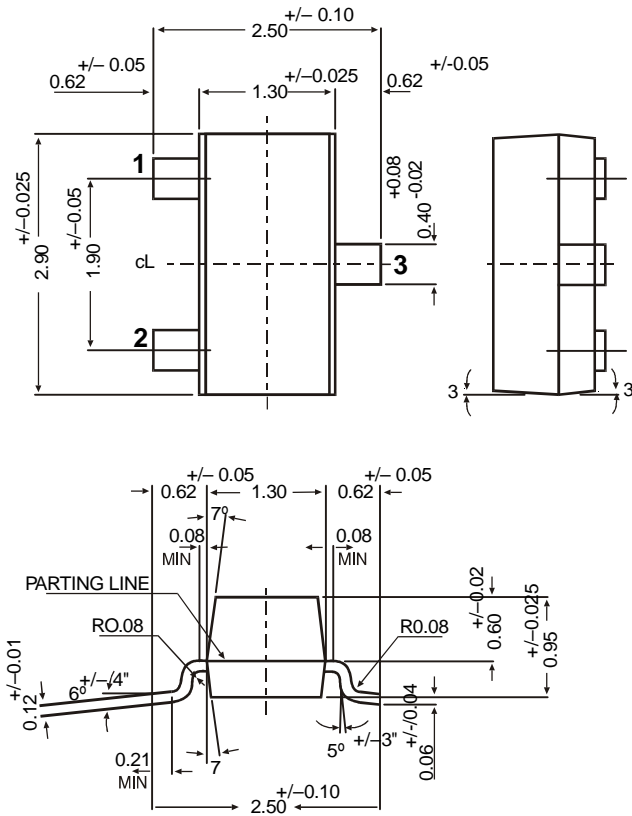

SOT-23 Package Reel Information  
Reel specifications for Packing (13"/7" reels)

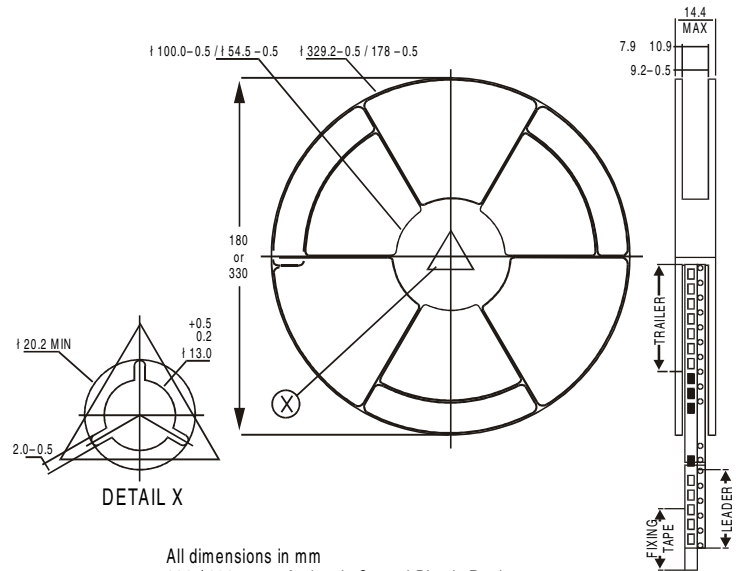

All dimensions in mm  
330 / 180 mm Antistatic Coated Plastic Reel

NOTES:

No. of Devices	8mm Tape Size of Reel 330 mm (13") 10,000 Pcs	8mm Tape Size of Reel 180 mm (7") 3,000 Pcs
----------------	--	--

- The bandoler of 330 mm reel contains at least 10,000 devices.
- The bandoler of 180 mm reel contains at least 3,000 devices.
- No more than 0.5% missing devices / reel. 50 empty compartments for 330 mm reel. 15 empty compartments for 180 mm reel.
- Three consecutive empty places might be found provided this gap is followed by 6 consecutive devices.
- The carrier tape (leader) starts with at least 75 empty positions (equivalent to 330 mm). In order to fix the carrier tape a self adhesive tape of 20 to 50 mm is applied. At the end of the bandoler at least 40 empty positions (equivalent to 160 mm) are there.

Tape Specification for SOT-23 Surface Mount Device

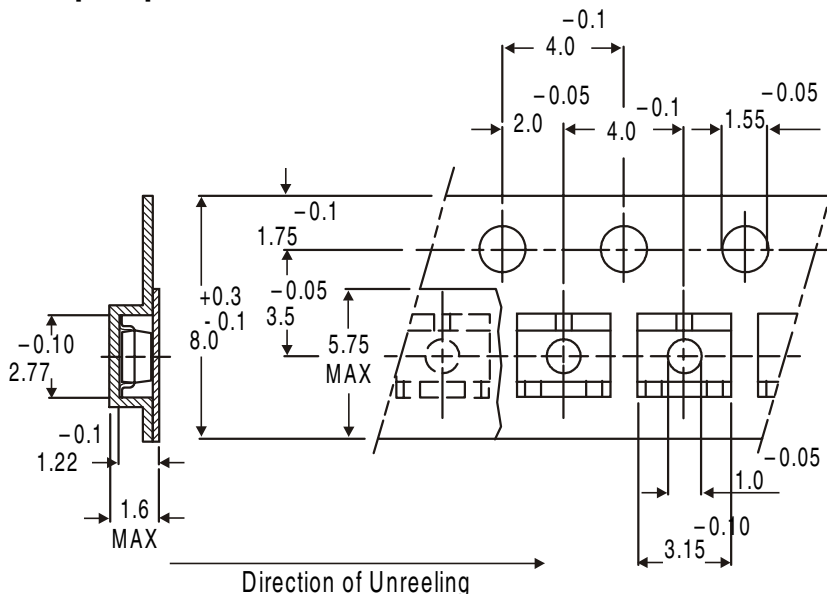

All dimensions in mm

## Packing Detail

PACKAGE	STANDARD PACK		INNER CARTON BOX		OUTER CARTON BOX		
	Details	Net Weight/Qty	Size	Qty	Size	Qty	Gr Wt
SOT-23 T&R	3K/reel	136 gm/3K pcs	3" x 7.5" x 7.5"	12.0K	17" x 15" x 13.5"	192.0K	12 kgs
			9" x 9" x 9"	51.0K	19" x 19" x 19"	408.0K	28 kgs
	10K/reel	415 gm/10K pcs	13" x 13" x 0.5"	10.0K	17" x 15" x 13.5"	300.0K	16 kgs

## Customer Notes

### Component Disposal Instructions

1. CDIL Semiconductor Devices are RoHS compliant, customers are requested to please dispose as per prevailing Environmental Legislation of their Country.
2. In Europe, please dispose as per EU Directive 2002/96/EC on Waste Electrical and Electronic Equipment (WEEE).

## Disclaimer

The product information and the selection guides facilitate selection of the CDIL's Semiconductor Device(s) best suited for application in your product(s) as per your requirement. It is recommended that you completely review our Data Sheet(s) so as to confirm that the Device(s) meet functionality parameters for your application. The information furnished on the CDIL Web Site/CD are believed to be accurate and reliable. CDIL however, does not assume responsibility for inaccuracies or incomplete information. Furthermore, CDIL does not assume liability whatsoever, arising out of the application or use of any CDIL product; neither does it convey any license under its patent rights nor rights of others. These products are not designed for use in life saving/support appliances or systems. CDIL customers selling these products (either as individual Discrete Semiconductor Devices or incorporated in their end products), in any life saving/support appliances or systems or applications do so at their own risk and CDIL will not be responsible for any damages resulting from such sale(s).

CDIL strives for continuous improvement and reserves the right to change the specifications of its products without prior notice.



CDIL is a registered Trademark of

Continental Device India Limited

C-120 Naraina Industrial Area, New Delhi 110 028, India.

Telephone + 91-11-2579 6150, 4141 1112 Fax + 91-11-2579 5290, 4141 1119

email@cdil.com www.cdilsemi.com