

NPN SILICON PLASTIC POWER DARLINGTON TRANSISTOR

**CN1933
(9AW)
TO-220**

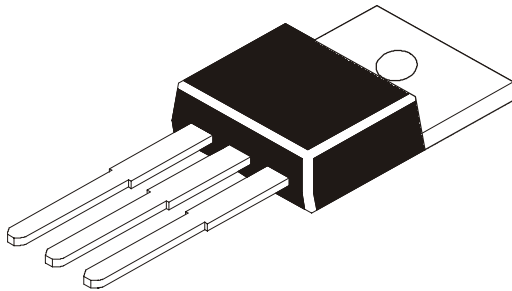

**MARKING: CN
1933**

**Low Freq. Power Amp.
Built in Damper Diode
Complementary CP1342**

ABSOLUTE MAXIMUM RATINGS(Ta=25deg C)

DESCRIPTION	SYMBOL	VALUE	UNIT
Collector -Base Voltage	VCBO	80	V
Collector -Emitter Voltage	VCEO	80	V
Emitter Base Voltage	VEBO	7.0	V
Collector Current DC	IC	4.0	A
Collector Current (Pulse*)		6.0	A
Collector Power Dissipation @ Ta=25 deg C	PC	2.0	W
Collector Power Dissipation @ Tc=25 deg C		60	W
Junction Temperature	Tj	150	deg C
Storage Temperature Range	Tstg	-55 to +150	deg C

*Single Pulse Pw=100ms

ELECTRICAL CHARACTERISTICS (Ta=25 deg C Unless Specified)

DESCRIPTION	SYMBOL	TEST CONDITION	MIN	TYP	MAX	UNIT
Collector Emitter Voltage	VCEO	IC=1mA, IB=0	80	-	-	V
Collector Base Voltage	VCBO	IC=50uA, IE=0	80	-	-	V
Collector Cut off Current	ICBO	VCB=80V, IE=0	-	-	100	uA
Emitter Cut off Current	IEBO	VEB=5V, IC=0	-	-	3.0	mA
Collector Emitter Saturation Voltage	VCE(Sat)	IC=2A, IB=4mA	-	-	1.5	V
DC Current Gain	hFE	IC=2A, VCE=3V	1.0	-	10	K
		IC=4A, VCE=3V	500	-	-	

Dynamic Characteristics

Transition Frequency	ft	VCE=5V, IC=0.2A, f=10MHz	-	40	-	MHz
Collector Output Capacitance	Cob	VCB=10V, IE=0 f=1MHz	-	35	-	pF

TO-220 Plastic Package

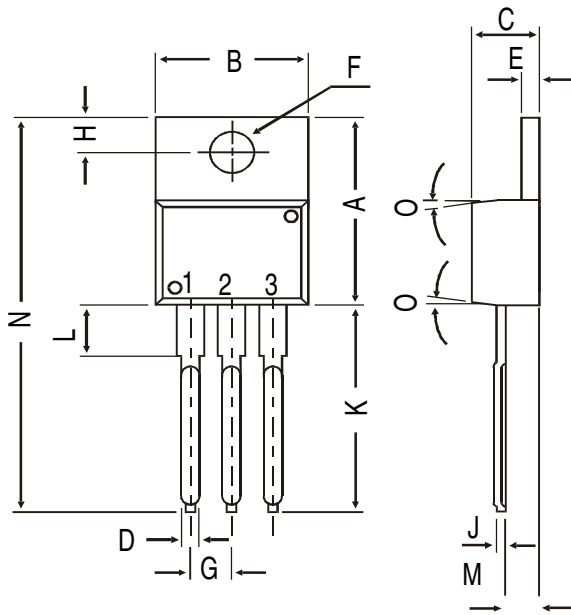

DIM	MIN.	MAX.
A	14.42	16.51
B	9.63	10.67
C	3.56	4.83
D	—	0.90
E	1.15	1.40
F	3.75	3.88
G	2.29	2.79
H	2.54	3.43
J	—	0.56
K	12.70	14.73
L	2.80	4.07
M	2.03	2.92
N	—	31.24
O	DEG 7	

All dimensions in mm.

PIN CONFIGURATION

1. BASE
2. COLLECTOR
3. EMITTER
4. COLLECTOR

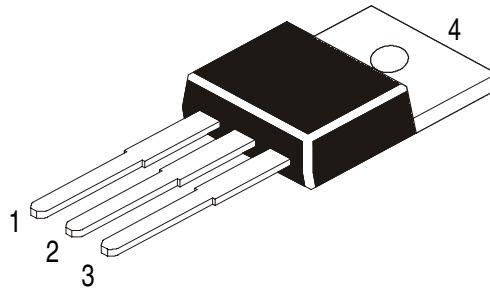

TO-220 Tube Packing

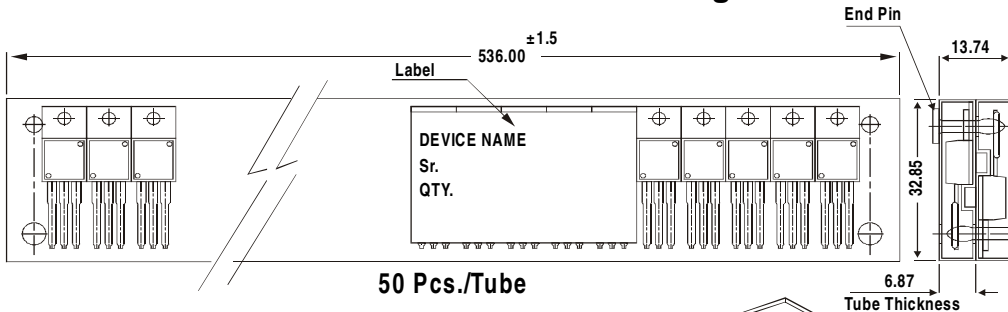

50 Pcs./Tube

AMMO PACK SIZE

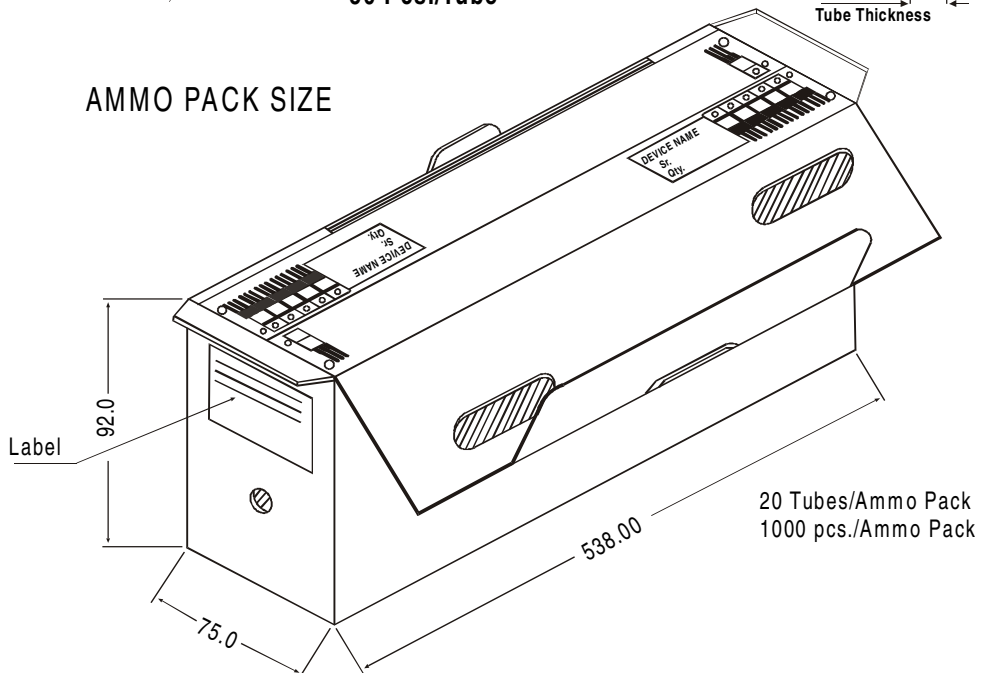

20 Tubes/Ammo Pack
1000 pcs./Ammo Pack

Packing Detail

PACKAGE	STANDARD PACK		INNER CARTON BOX		OUTER CARTON BOX		
	Details	Net Weight/Qty	Size	Qty	Size	Qty	Gr Wt
TO-220 / FP	200 pcs/polybag	396 gm/200 pcs	3" x 7.5" x 7.5"	1.0K	17" x 15" x 13.5"	16.0K	36 kgs
	50 pcs/tube	120 gm/50 pcs	3.5" x 3.7" x 21.5"	1.0K	19" x 19" x 19"	10.0K	29 kgs

Notes

Disclaimer

The product information and the selection guides facilitate selection of the CDIL's Discrete Semiconductor Device(s) best suited for application in your product(s) as per your requirement. It is recommended that you completely review our Data Sheet(s) so as to confirm that the Device(s) meet functionality parameters for your application. The information furnished on the CDIL Web Site/CD is believed to be accurate and reliable. CDIL however, does not assume responsibility for inaccuracies or incomplete information. Furthermore, CDIL does not assume liability whatsoever, arising out of the application or use of any CDIL product; neither does it convey any license under its patent rights nor rights of others. These products are not designed for use in life saving/support appliances or systems. CDIL customers selling these products (either as individual Discrete Semiconductor Devices or incorporated in their end products), in any life saving/support appliances or systems or applications do so at their own risk and CDIL will not be responsible for any damages resulting from such sale(s).

CDIL strives for continuous improvement and reserves the right to change the specifications of its products without prior notice.



CDIL is a registered Trademark of

Continental Device India Limited

C-120 Naraina Industrial Area, New Delhi 110 028, India.

Telephone + 91-11-579 6150 Fax + 91-11-579 9569, 579 5290

e-mail sales@cdil.com www.cdil.com