

PNP SILICON PLANAR DARLINGTON POWER TRANSISTOR

CJF6668

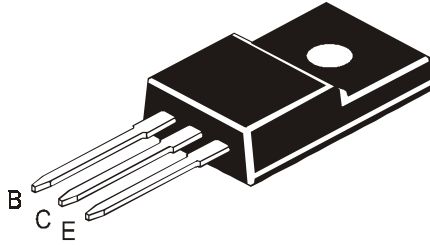

TO-220FP Fully Isolated Plastic Package

Complementary CJF6388

General Purpose Darlington Amplifier and Switching Applications

ABSOLUTE MAXIMUM RATINGS.

DESCRIPTION	SYMBOL	VALUE	UNIT
Collector Base Voltage	V_{CBO}	100	V
Collector Emitter Voltage	V_{CEO}	100	V
Emitter Base Voltage	V_{EBO}	5	V
RMS Isolation Voltage (for 1sec,R.H.<30%, $T_A=25^{\circ}C$)	(1) V_{ISOL} (a)	3500	V_{RMS}
	(b)	1500	V_{RMS}
Collector Current - Continuous	I_C	10	A
		Peak (2)	15
Base Current	I_B	1	A
Total Power Dissipation @ $T_c=25^{\circ}C$	$P_{D^{**}}$	40	W
Derate Above $25^{\circ}C$		0.31	W/ $^{\circ}C$
Total Power Dissipation @ $T_a=25^{\circ}C$	P_D	2	W
Derate Above $25^{\circ}C$		0.016	W/ $^{\circ}C$
Operating and Storage Junction Temperature Range	T_j, T_{stg}	- 65 to +150	$^{\circ}C$
THERMAL RESISTANCE			
From Junction to Case	$R_{th(j-c)^{**}}$	3.2	$^{\circ}C/W$
From Junction to Ambient	$R_{th(j-a)}$	62.5	$^{\circ}C/W$
Lead Temperature for Soldering Purpose	T_L	260	$^{\circ}C$

****Measurement made with thermocouple contacting the bottom insulated mounting surface (in a location beneath the die), the device mounted on a heatsink with thermal grease and a mounting torque of ≥ 6 in.lbs.**

(1) RMS Isolation Voltage : (a) 3500 V_{RMS} with Package in Clip Mounting Position (b) 1500 V_{RMS} with Package in Screw Mounting Position (for 1sec, R.H.<30% , $T_a=25^{\circ}C$; Pulse Test: Pulse Width $\leq 300\mu s$, Duty Cycle $\leq 2\%$)

(2) Pulse Test : Pulse Width =5ms, Duty Cycle $\leq 10\%$

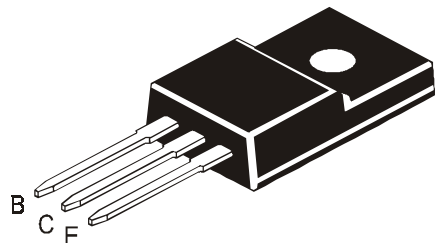

TO-220FP Fully Isolated
Plastic Package

ELECTRICAL CHARACTERISTICS (T_c=25°C unless specified otherwise)

DESCRIPTION	SYMBOL	TEST CONDITION	MIN	MAX	UNIT
Collector Emitter sustaining Voltage	V _{CEO(sus)} *	I _C =30mA, I _B =0	100		V
Collector Cut off Current	I _{CEO}	V _{CE} =80V, I _B =0		10	μA
	I _{CEX}	V _{CE} =100V, V _{EB(off)} =1.5V		10	μA
		T _C =125°C			
		V _{CE} =100V, V _{EB(off)} =1.5V		3	mA
Emitter Cut off Current	I _{CBO}	V _{CB} =100V, I _E =0		10	μA
	I _{EBO}	V _{EB} =5V, I _C =0		2	mA
DC Current Gain	h _{FE} *	I _C =3A, V _{CE} =4V	3000	15000	
		I _C =5A, V _{CE} =3V	1000		
		I _C =8A, V _{CE} =4V	200		
		I _C =10A, V _{CE} =3V	100		
Collector Emitter Saturation Voltage	V _{CE(Sat)} *	I _C =3A, I _B =6mA		2	V
		I _C =5A, I _B =0.01A		2	V
		I _C =8A, I _B =80mA		2.5	V
		I _C =10A, I _B =0.1A		3	V
Base Emitter Saturation Voltage	V _{BE(Sat)} *	I _C =5A, I _B =0.01A		2.8	V
		I _C =10A, I _B =0.1A		4.5	V
Base Emitter on Voltage	V _{BE(on)} *	I _C =8A, V _{CE} =4V		2.5	V
<u>DYNAMIC CHARACTERISTICS</u>					
Small Signal Current Gain	h _{fe} l	I _C =1A, V _{CE} =5V, f=1MHz	20		
Output Capacitance	C _{ob}	V _{CB} =10V, I _E =0, f=1MHz		300	pF
Small Signal Current Gain	h _{fe}	I _C =1A, V _{CE} =5V, f=1kHz	1000		

* Pulse Test: Pulse Width ≤300μs, Duty Cycle ≤2 %

TO-220FP Fully Isolated Plastic Package

TO-220FP Fully Isolated Plastic Package

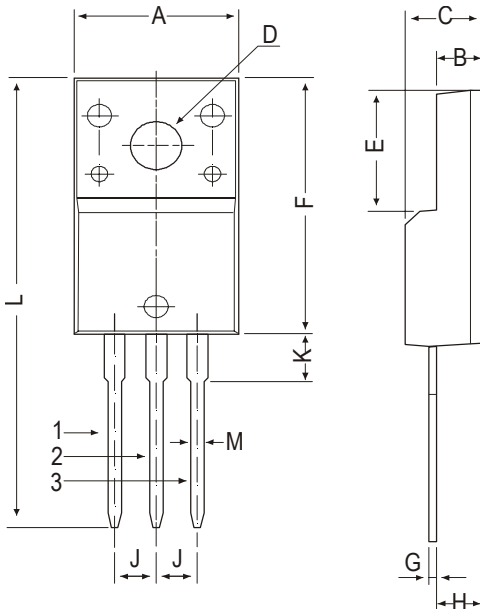

DIM	MIN	MAX
A	9.96	10.36
B	2.60	3.00
C	4.50	4.90
D	3.10	3.30
E	7.90	8.20
F	16.87	17.27
G	0.45	0.50
H	2.56	2.96
J	2.34	2.74
K	—	3.08
L	—	30.05
M	—	0.80

All dimensions in mm.

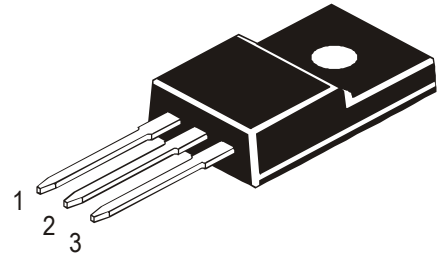

Pin Configuration

- 1. Base
- 2. Collector
- 3. Emitter

TO-220 FP Tube Packing

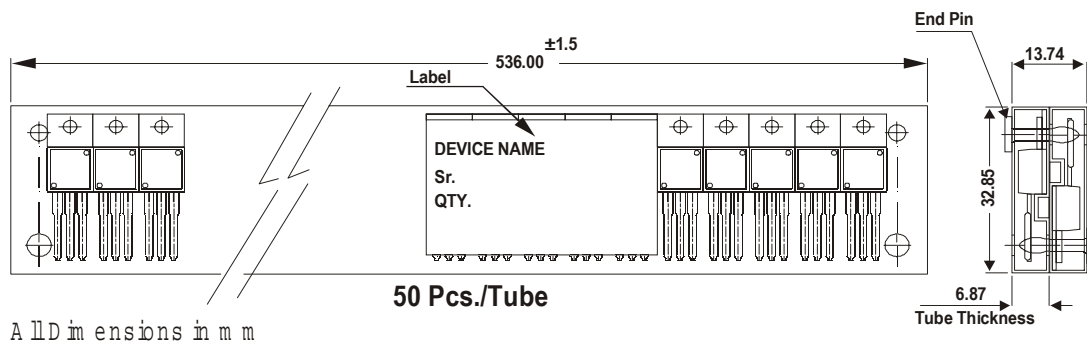

All dimensions in mm

50 Pcs./Tube

AMMO PACK SIZE

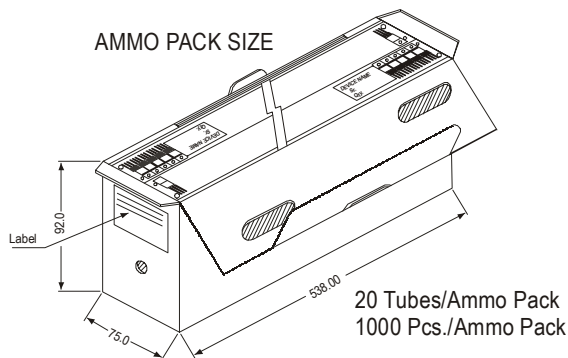

20 Tubes/Ammo Pack
1000 Pcs./Ammo Pack

Packing Detail

PACKAGE	STANDARD PACK		INNER CARTON BOX		OUTER CARTON BOX		
	Details	Net Weight/Qty	Size	Qty	Size	Qty	Gr Wt
TO-220FP	200 pcs/polybag	396 gm/200 pcs	3" x 7.5" x 7.5"	1K	17" x 15" x 13.5"	16K	36 kgs
	50 pcs/tube	135 gm/50 pcs	3.5" x 3.7" x 21.5"	1K	19" x 19" x 19"	10K	28 kgs

**TO-220FP Fully Isolated
Plastic Package****Disclaimer**

The product information and the selection guides facilitate selection of the CDIL's Discrete Semiconductor Device(s) best suited for application in your product(s) as per your requirement. It is recommended that you completely review our Data Sheet(s) so as to confirm that the Device(s) meet functionality parameters for your application. The information furnished in the Data Sheet and on the CDIL Web Site/CD are believed to be accurate and reliable. CDIL however, does not assume responsibility for inaccuracies or incomplete information. Furthermore, CDIL does not assume liability whatsoever, arising out of the application or use of any CDIL product; neither does it convey any license under its patent rights nor rights of others. These products are not designed for use in life saving/support appliances or systems. CDIL customers selling these products (either as individual Discrete Semiconductor Devices or incorporated in their end products), in any life saving/support appliances or systems or applications do so at their own risk and CDIL will not be responsible for any damages resulting from such sale(s).

CDIL strives for continuous improvement and reserves the right to change the specifications of its products without prior notice.



CDIL is a registered Trademark of

Continental Device India Limited

C-120 Naraina Industrial Area, New Delhi 110 028, India.

Telephone + 91-11-2579 6150, 5141 1112 Fax + 91-11-2579 5290, 5141 1119

email@cdil.com www.cdilsemi.com