

PNP SILICON EPITAXIAL POWER TRANSISTOR

**CDB1370EF
(9AW)
TO126**

**MARKING: CDB
1370
EF**

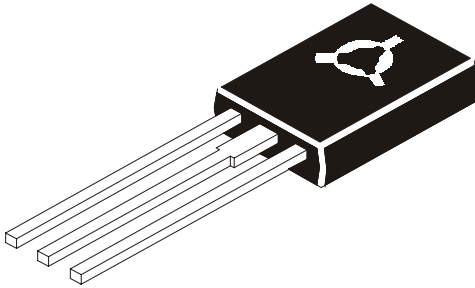

Low Freq. Power Amp.

ABSOLUTE MAXIMUM RATINGS(Ta=25deg C)

DESCRIPTION	SYMBOL	VALUE	UNIT
Collector -Base Voltage	VCBO	60	V
Collector -Emitter Voltage	VCEO	60	V
Emitter Base Voltage	VEBO	5	V
Collector Current Continuous	IC	2	A
Peak*		4	A
Collector Power Dissipation @ Ta=25 deg C	PC	1.5	W
Collector Power Dissipation @ Tc=25 deg C		25	W
Junction Temperature	Tj	150	deg C
Storage Temperature Range	Tstg	-55 to +150	deg C

*Single Pulse Pw=100ms

ELECTRICAL CHARACTERISTICS (Ta=25 deg C Unless Specified)

DESCRIPTION	SYMBOL	TEST CONDITION	MIN	TYP	MAX	UNIT
Collector Emitter Voltage	VCEO	IC=1mA, IB=0	60	-	-	V
Collector Base Voltage	VCBO	IC=50uA, IE=0	60	-	-	V
Emitter Base Voltage	VEBO	IE=50uA, IC=0	5	-	-	V
Collector Cut off Current	ICBO	VCB=60V, IE=0	-	-	10	uA
	ICEO	VCE=60V, IB=0	-	-	1	uA
Emitter Cut off Current	IEBO	VBE=4V, IC=0	-	-	10	uA
Collector Emitter Saturation Voltage	VCE(Sat)**	IC=2A, IB=0.2A	-	-	1.5	V
Base Emitter Saturation Voltage	VBE(Sat)**	IC=2A, IB=0.2A	-	-	1.5	V
DC Current Gain	hFE**	IC=0.5A, VCE=5V	100	-	300	
Dynamic Characteristics						
Transition Frequency	ft	VCE=5V, IC=0.5A, f=5MHz	-	15	-	MHz
Collector Output Capacitance	Cob	VCB=10V, IE=0, f=1MHz	-	80	-	pF

**Pulse Test

TO-126 (SOT-32) Plastic Package

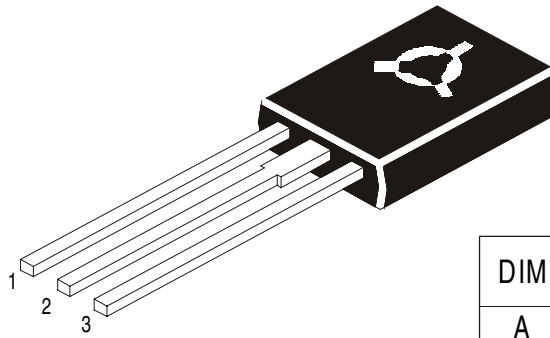
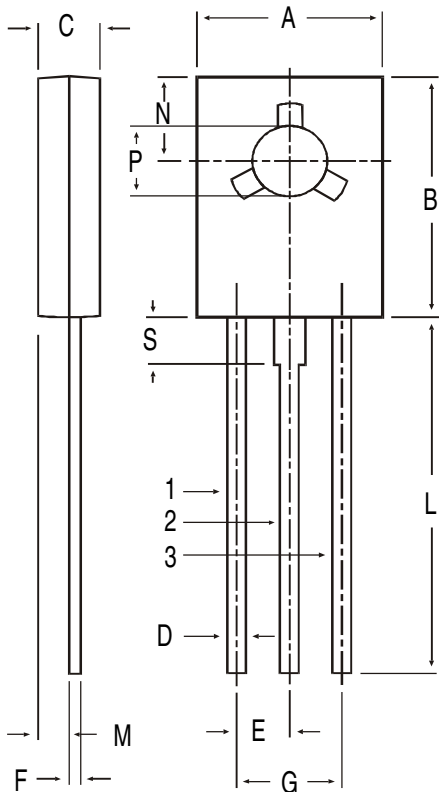

PIN CONFIGURATION

1. EMITTER
2. COLLECTOR
3. BASE

All dimensions in mm.

DIM	MIN.	MAX.
A	7.4	7.8
B	10.5	10.8
C	2.4	2.7
D	0.7	0.9
E	2.25 TYP.	
F	0.49	0.75
G	4.5 TYP.	
L	15.7 TYP.	
M	1.27 TYP.	
N	3.75 TYP.	
P	3.0	3.2
S	2.5 TYP.	

Packing Detail

PACKAGE	STANDARD PACK		INNER CARTON BOX		OUTER CARTON BOX		
	Details	Net Weight/Qty	Size	Qty	Size	Qty	Gr Wt
TO-126	500 pcs/polybag	340 gm/500 pcs	3" x 7.5" x 7.5"	2.0K	17" x 15" x 13.5"	32.0K	31 kgs

Disclaimer

The product information and the selection guides facilitate selection of the CDIL's Discrete Semiconductor Device(s) best suited for application in your product(s) as per your requirement. It is recommended that you completely review our Data Sheet(s) so as to confirm that the Device(s) meet functionality parameters for your application. The information furnished on the CDIL Web Site/CD is believed to be accurate and reliable. CDIL however, does not assume responsibility for inaccuracies or incomplete information. Furthermore, CDIL does not assume liability whatsoever, arising out of the application or use of any CDIL product; neither does it convey any license under its patent rights nor rights of others. These products are not designed for use in life saving/support appliances or systems. CDIL customers selling these products (either as individual Discrete Semiconductor Devices or incorporated in their end products), in any life saving/support appliances or systems or applications do so at their own risk and CDIL will not be responsible for any damages resulting from such sale(s).

CDIL strives for continuous improvement and reserves the right to change the specifications of its products without prior notice.



CDIL is a registered Trademark of

Continental Device India Limited

C-120 Naraina Industrial Area, New Delhi 110 028, India.

Telephone + 91-11-579 6150 Fax + 91-11-579 9569, 579 5290

e-mail sales@cdil.com www.cdil.com