

PNP SILICON EPITAXIAL POWER TRANSISTOR

**BD 240C
(BPL)
TO-220**

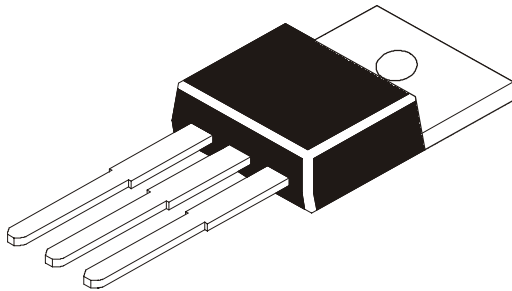

Complementary Silicon transistor Intended For A Wide Variety Of Switching & Amplifier Applications, Series And Shunt Regulators, Driver And Output Stages of HI-FI Amplifiers

ABSOLUTE MAXIMUM RATINGS(Ta=25deg C)

DESCRIPTION	SYMBOL	VALUE	UNIT
Collector -Base Voltage	VCBO	115	V
Collector -Emitter Voltage	VCEO	100	V
Emitter Base Voltage	VEBO	5.0	V
Collector Current Continuous	IC	2.0	A
Peak	ICM	4.0	A
Base Current	IB	0.6	A
Collector Power Dissipation @ Ta=25 deg C	PD	2.0	W
Derate Above 25 deg C		16	mW/deg C
Collector Power Dissipation @ Tc=25 deg C	PD	30	W
Derate Above 25 deg C		240	mW/deg C
Unclamped Inductive Load Energy (1)	E	32	mj
Junction Temperature	Tj	150	deg C
Storage Temperature Range	Tstg	-65 to +150	deg C
Thermal Resistance			
Junction to Ambient	Rth(j-a)	62.5	deg C/W
Junction to Case	Rth(j-c)	4.17	deg C/W

(1)Lc=20mH, RBE=100 ohms, RE=0.1 ohms , IC=1.8A.

ELECTRICAL CHARACTERISTICS (Ta=25 deg C Unless Specified)

DESCRIPTION	SYMBOL	TEST CONDITION	MIN	TYP	MAX	UNIT
Collector Emitter (sus) Voltage	VCEO(sus)*	IC=30mA, IB=0	100	-	-	V
Collector Cut off Current	ICEO	VCE=60V, IB=0	-	-	0.3	mA
	ICES	VCE=100V, VBE=0	-	-	0.2	mA
Emitter Cut off Current	IEBO	VBE=5V, IC=0	-	-	1.0	mA
DC Current Gain	hFE*	IC=0.2A, VCE=4V	40	-	-	
		IC=1A, VCE=4V	15	-	-	
Collector Emitter Saturation Voltage	VCE(Sat)*	IC=1A, IB=0.2A	-	-	0.7	V
Base Emitter on Voltage	VBE(on)*	IC=1A, VCE=4V	-	-	1.3	V

ELECTRICAL CHARACTERISTICS (Ta=25 deg C Unless Specified)

BD240C

DESCRIPTION	SYMBOL	TEST CONDITION	MIN	TYP	MAX	UNIT
Dynamic Characteristics						
Small Signal Current Gain	hfe	VCE=10V, IC=0.2A f=1kHz	20		-	
Transition Frequency	ft	VCE=10V, IC=0.2A, f=1MHz	3.0		-	MHz

*Pulse Condition: Pulse Width =300us, Duty Cycle=2%

TO-220 Plastic Package

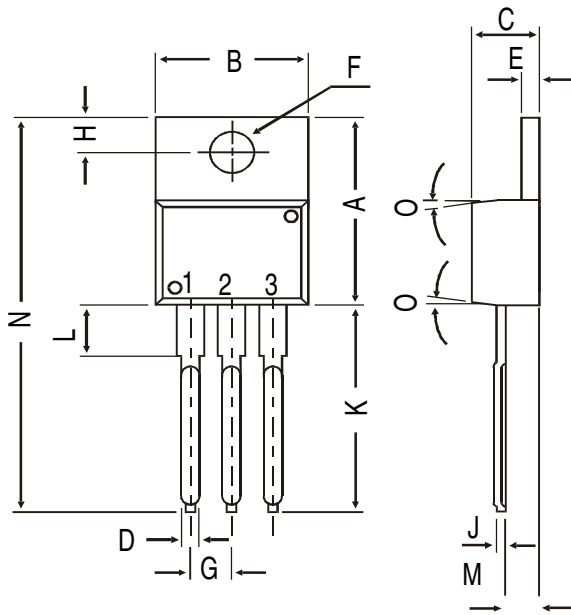

DIM	MIN.	MAX.
A	14.42	16.51
B	9.63	10.67
C	3.56	4.83
D	—	0.90
E	1.15	1.40
F	3.75	3.88
G	2.29	2.79
H	2.54	3.43
J	—	0.56
K	12.70	14.73
L	2.80	4.07
M	2.03	2.92
N	—	31.24
O	DEG 7	

All dimensions in mm.

PIN CONFIGURATION

1. BASE
2. COLLECTOR
3. EMITTER
4. COLLECTOR

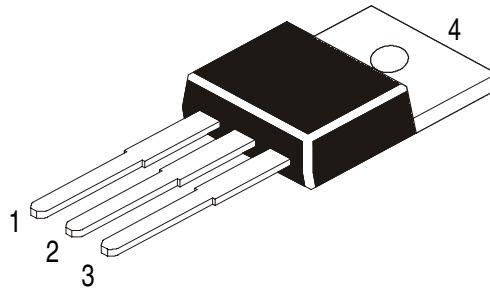

TO-220 Tube Packing

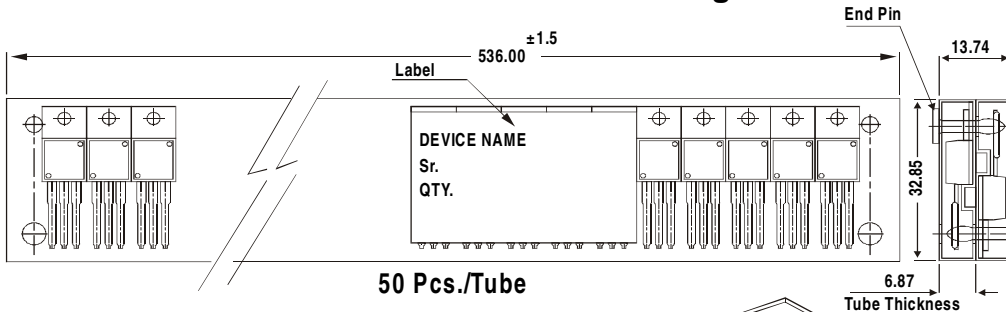

AMMO PACK SIZE

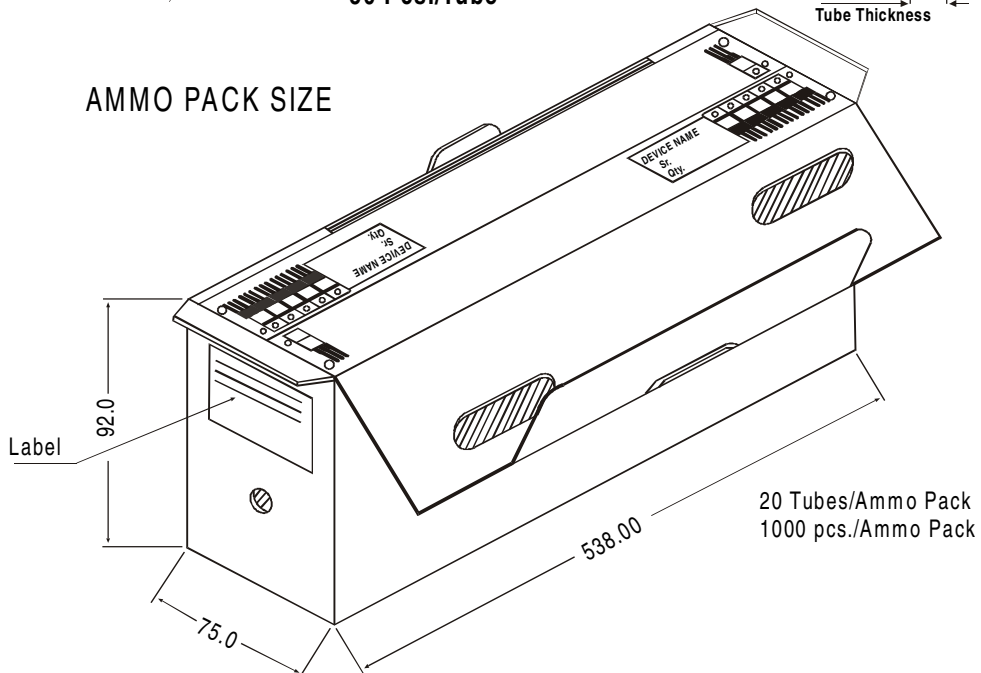

Packing Detail

PACKAGE	STANDARD PACK		INNER CARTON BOX		OUTER CARTON BOX		
	Details	Net Weight/Qty	Size	Qty	Size	Qty	Gr Wt
TO-220 / FP	200 pcs/polybag	396 gm/200 pcs	3" x 7.5" x 7.5"	1.0K	17" x 15" x 13.5"	16.0K	36 kgs
	50 pcs/tube	120 gm/50 pcs	3.5" x 3.7" x 21.5"	1.0K	19" x 19" x 19"	10.0K	29 kgs

Notes

Disclaimer

The product information and the selection guides facilitate selection of the CDIL's Discrete Semiconductor Device(s) best suited for application in your product(s) as per your requirement. It is recommended that you completely review our Data Sheet(s) so as to confirm that the Device(s) meet functionality parameters for your application. The information furnished on the CDIL Web Site/CD is believed to be accurate and reliable. CDIL however, does not assume responsibility for inaccuracies or incomplete information. Furthermore, CDIL does not assume liability whatsoever, arising out of the application or use of any CDIL product; neither does it convey any license under its patent rights nor rights of others. These products are not designed for use in life saving/support appliances or systems. CDIL customers selling these products (either as individual Discrete Semiconductor Devices or incorporated in their end products), in any life saving/support appliances or systems or applications do so at their own risk and CDIL will not be responsible for any damages resulting from such sale(s).

CDIL strives for continuous improvement and reserves the right to change the specifications of its products without prior notice.



CDIL is a registered Trademark of

Continental Device India Limited

C-120 Naraina Industrial Area, New Delhi 110 028, India.

Telephone + 91-11-579 6150 Fax + 91-11-579 9569, 579 5290

e-mail sales@cdil.com www.cdil.com