

TO-220 Plastic Package

2N6290

2N6290 NPN PLASTIC POWER TRANSISTOR

Complementary 2N6109

Medium Power Switching and Linear Applications

PIN CONFIGURATION

- 1. BASE
- 2. COLLECTOR
- 3. EMITTER
- 4. COLLECTOR

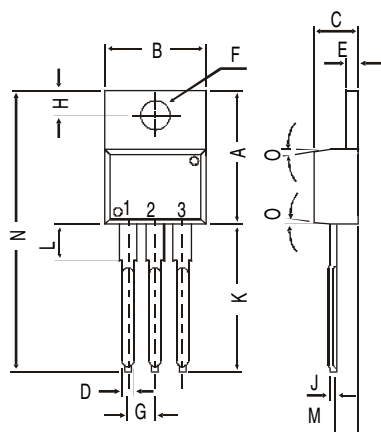
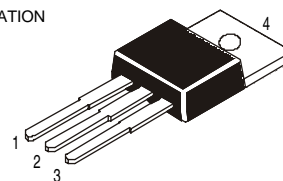

All dimensions in mm.

DIM	MIN.	MAX.
A	14.42	16.51
B	9.63	10.67
C	3.56	4.83
D		0.90
E	1.15	1.40
F	3.75	3.88
G	2.29	2.79
H	2.54	3.43
J		0.56
K	12.70	14.73
L	2.80	4.07
M	2.03	2.92
N		31.24
O		DEG 7

ABSOLUTE MAXIMUM RATINGS

Collector-base voltage (open emitter)	V_{CBO}	max.	60 V
Collector-emitter voltage (open base)	V_{CEO}	max.	50 V
Collector current	I_C	max.	7.0 A
Total power dissipation up to $T_C = 25^\circ\text{C}$	P_{tot}	max.	40 W
Junction temperature	T_j	max.	150 °C
Collector-emitter saturation voltage $I_C = 2.5 \text{ A}; I_B = 0.25 \text{ A}$	V_{CEsat}	max.	1.0 V
D.C. current gain $I_C = 2.5 \text{ A}; V_{CE} = 4 \text{ V}$	h_{FE}	min.	30
		max.	150

RATINGS (at $T_A=25^\circ\text{C}$ unless otherwise specified)

Limiting values

Collector-base voltage (open emitter)	V_{CBO}	max.	60 V
Collector-emitter voltage (open base)	V_{CEO}	max.	50 V
Collector-emitter voltage ($V_{BE} = 1.5\text{V}$)	V_{CEX}	max.	60 V
Collector-emitter voltage ($R_{BE} = 100\Omega$)	V_{CER}	max.	60 V
Emitter-base voltage (open collector)	V_{EBO}	max.	5.0 V

2N6290

Collector current	I_C	max.	7.0 A
Base current	I_B	max.	3.0 A
Total power dissipation up to $T_C = 25^\circ\text{C}$	P_{tot}	max.	40 W
Junction temperature	T_j	max.	150 °C
Storage temperature	T_{stg}		-65 to +150 °C

THERMAL RESISTANCE

From junction to ambient	$R_{th\ j-a}$	=	70 °C/W
From junction to case	$R_{th\ j-c}$	=	3.125 °C/W

CHARACTERISTICS

$T_{amb} = 25^\circ\text{C}$ unless otherwise specified

Collector cutoff current

$I_B = 0; V_{CE} = 40\text{ V}$	I_{CEO}	max.	1.0 mA
$V_{BE} = 1.5\text{ V}; V_{CE} = 60\text{ V}$	I_{CEX}	max.	0.1 mA
$V_{BE} = 1.5\text{ V}; V_{CE} = 50\text{ V}; T_C = 150^\circ\text{C}$	I_{CEX}	max.	2.0 mA

Emitter cut-off current

$I_C = 0; V_{EB} = 5\text{ V}$	I_{EBO}	max.	1 mA
--------------------------------	-----------	------	------

Breakdown voltages

$I_C = 0.1\text{ A}; I_B = 0$	$V_{CEO(sus)}^*$	min.	50 V
$I_C = 1\text{ mA}; I_E = 0$	V_{CBO}	min.	60 V
$I_E = 1\text{ mA}; I_C = 0$	V_{EBO}	min.	5.0 V

Saturation voltages

$I_C = 2.5\text{ A}; I_B = 0.25\text{ A}$	V_{CEsat}^*	max.	1.0 V
$I_C = 7\text{ A}; I_B = 3\text{ A}$	V_{CEsat}^*	max.	3.5 V

Base emitter on voltage

$I_C = 2.5\text{ A}; V_{CE} = 4\text{ V}$	$V_{BE(on)}^*$	max.	1.5 V
$I_C = 7\text{ A}; V_{CE} = 4\text{ V}$	$V_{BE(on)}^*$	max.	3.0 V

D.C. current gain

$I_C = 2.5\text{ A}; V_{CE} = 4\text{ V}$	h_{FE}^*	min.	30
		max.	150

$I_C = 7\text{ A}; V_{CE} = 4\text{ V}$	h_{FE}^*	min.	2.3
---	------------	------	-----

Small signal current gain

$I_C = 0.5\text{ A}; V_{CE} = 4\text{ V}$	h_{fe}	min.	20
---	----------	------	----

Output capacitance at $f = 1\text{ MHz}$

$I_E = 0; V_{CB} = 10\text{ V}$	C_o	max.	250 pF
---------------------------------	-------	------	--------

Transition frequency

$I_C = 0.5\text{ A}; V_{CE} = 4\text{ V}$	f_T	min.	4 MHz
---	-------	------	-------

* Pulsed: pulse duration = 300 μs ; duty cycle = 1.5%

Notes

Disclaimer

The product information and the selection guides facilitate selection of the CDIL's Discrete Semiconductor Device(s) best suited for application in your product(s) as per your requirement. It is recommended that you completely review our Data Sheet(s) so as to confirm that the Device(s) meet functionality parameters for your application. The information furnished on the CDIL Web Site/ CD is believed to be accurate and reliable. CDIL however, does not assume responsibility for inaccuracies or incomplete information. Furthermore, CDIL does not assume liability whatsoever, arising out of the application or use of any CDIL product; neither does it convey any license under its patent rights nor rights of others. These products are not designed for use in life saving/support appliances or systems. CDIL customers selling these products (either as individual Discrete Semiconductor Devices or incorporated in their end products), in any life saving/support appliances or systems or applications do so at their own risk and CDIL will not be responsible for any damages resulting from such sale(s).

CDIL strives for continuous improvement and reserves the right to change the specifications of its products without prior notice.



CDIL is a registered Trademark of
Continental Device India Limited

C-120 Naraina Industrial Area, New Delhi 110 028, India.
Telephone + 91-11-2579 6150, 5141 1112 Fax + 91-11-2579 5290, 5141 1119
email@cdil.com www.cdilsemi.com