

SILICON PLANAR SWITCHING DIODE

**BAL99
SOT-23**

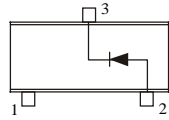
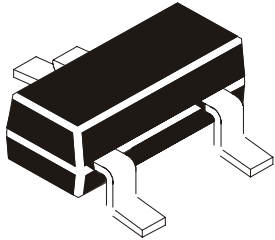

Pin Configuration
1 = NC
2 = ANODE
3 = CATHODE

MARKING- TF

ABSOLUTE MAXIMUM RATINGS

DESCRIPTION	SYMBOL	VALUE	UNIT
Continuous Reverse Voltage	VR	70	V
Peak Forward Current	IF	100	mA
Total Device Dissipation FR-5 Board* Ta=25 deg C	PD	225	mW
Derate Above=25 deg C		1.80	mW/deg C
Thermal Resistance Junction to Ambient	Rth(j-a)	556	deg C/W
Total Device Dissipation Alumina Substrate,** Ta=25 deg C	PD	300	mW
Derate Above=25 deg C		2.40	mW/deg C
Thermal Resistance Junction to Ambient	Rth(j-a)	417	deg C/W
Junction & Storage Temperature	Tj, Tstg	-55 to +150	deg C

*FR-5=1.0 x 0.75 x 0.062 in.

** Alumina= 0.4 x 0.3 x 0.024 in 99.5% alumina

ELECTRICAL CHARACTERISTICS (Ta=25 deg C Unless otherwise noted)

DESCRIPTION	SYMBOL	TEST CONDITION	MIN	TYP	MAX	UNIT
Reverse Voltage Leakage Current	IR	VR=70V	-	-	2.50	uA
		VR=25V, Tj=150 deg C	-	-	30	uA
		VR=70V, Tj=150 deg C	-	-	50	uA
Reverse Breakdown Voltage	V(BR)	IR=100uA	70	-	-	V
Forward Voltage	VF	IF=1.0mA	-	-	715	mV
		IF=10mA	-	-	855	mV
		IF=50mA	-	-	1000	mV
		IF=150mA	-	-	1250	mV
Recovery Current	QS	IF=10mA, VR=5V, RL=500 ohms	-	-	45	pC
Diode Capacitance	CD	VR=0V, f=1MHz	-	-	1.5	pF
Reverse Recovery Time	trr	IF=IR=10mA, RL= 100 ohms measured @ IR=1.0 mA	-	-	6.0	ns
Forward Recovery Voltage	VFR	IF=10mA, tr=20ns	-	-	1.75	V

SOT-23 Formed SMD Package

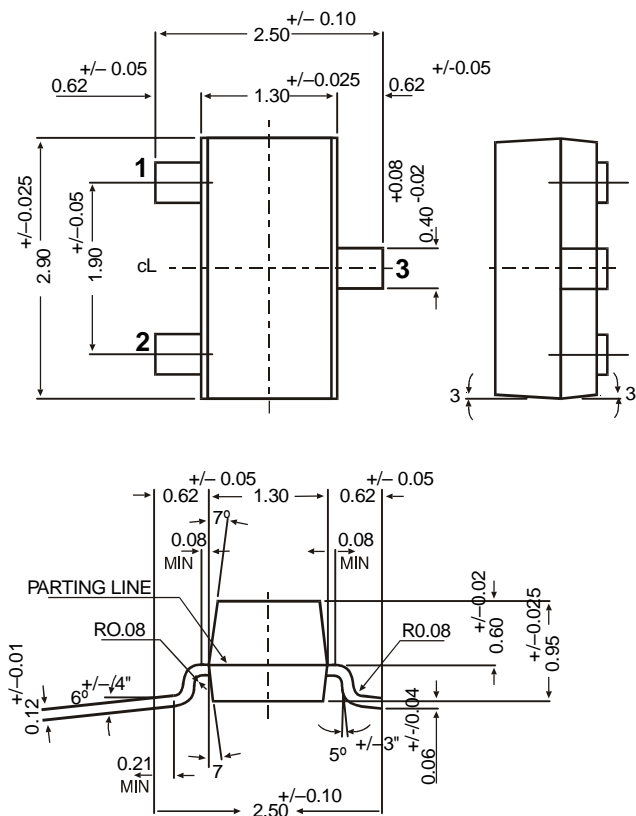

SOT-23 Package Reel Information Reel specifications for Packing (13"/7" reels)

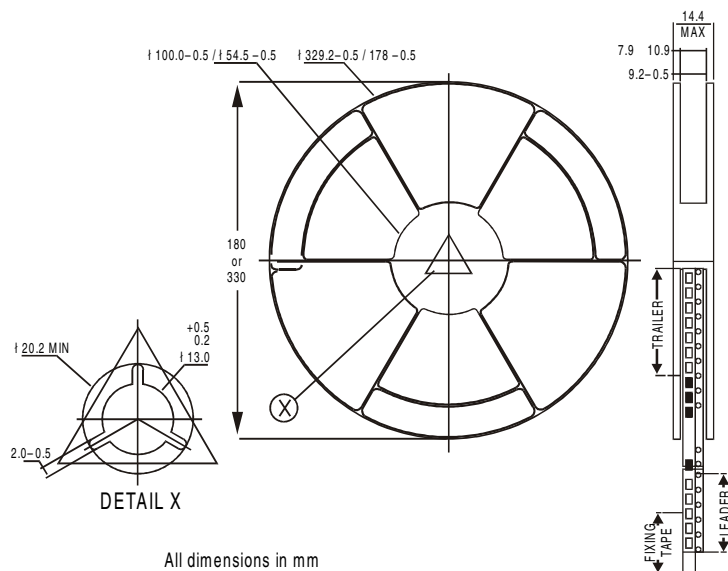

All dimensions in mm
330 / 180 mm Antistatic Coated Plastic Reel

NOTES:

No. of Devices	8mm Tape Size of Reel 330 mm (13") 10,000 Pcs	8mm Tape Size of Reel 180 mm (7") 3,000 Pcs
----------------	--	--

- The bandolier of 330 mm reel contains at least 10,000 devices.
- The bandolier of 180 mm reel contains at least 3,000 devices.
- No more than 0.5% missing devices / reel. 50 empty compartments for 330 mm reel. 15 empty compartments for 180 mm reel.
- Three consecutive empty places might be found provided this gap is followed by 6 consecutive devices.
- The carrier tape (leader) starts with at least 75 empty positions (equivalent to 330 mm). In order to fix the carrier tape a self adhesive tape of 20 to 50 mm is applied. At the end of the bandolier at least 40 empty positions (equivalent to 160 mm) are there.

Tape Specification for SOT-23 Surface Mount Device

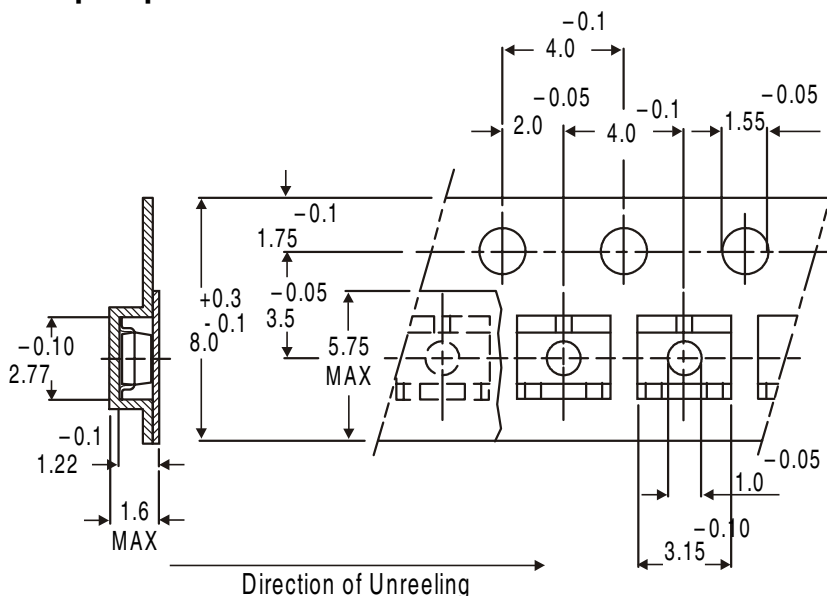

All dimensions in mm

Packing Detail

PACKAGE	STANDARD PACK		INNER CARTON BOX		OUTER CARTON BOX		
	Details	Net Weight/Qty	Size	Qty	Size	Qty	Gr Wt
SOT-23 T&R	3K/reel	136 gm/3K pcs	3" x 7.5" x 7.5"	12.0K	17" x 15" x 13.5"	192.0K	12 kgs
			9" x 9" x 9"	51.0K	19" x 19" x 19"	408.0K	28 kgs
	10K/reel	415 gm/10K pcs	13" x 13" x 0.5"	10.0K	17" x 15" x 13.5"	300.0K	16 kgs

Customer Notes

Component Disposal Instructions

1. CDIL Semiconductor Devices are RoHS compliant, customers are requested to please dispose as per prevailing Environmental Legislation of their Country.
2. In Europe, please dispose as per EU Directive 2002/96/EC on Waste Electrical and Electronic Equipment (WEEE).

Disclaimer

The product information and the selection guides facilitate selection of the CDIL's Discrete Semiconductor Device(s) best suited for application in your product(s) as per your requirement. It is recommended that you completely review our Data Sheet(s) so as to confirm that the Device(s) meet functionality parameters for your application. The information furnished on the CDIL Web Site/CD is believed to be accurate and reliable. CDIL however, does not assume responsibility for inaccuracies or incomplete information. Furthermore, CDIL does not assume liability whatsoever, arising out of the application or use of any CDIL product; neither does it convey any license under its patent rights nor rights of others. These products are not designed for use in life saving/support appliances or systems. CDIL customers selling these products (either as individual Discrete Semiconductor Devices or incorporated in their end products), in any life saving/support appliances or systems or applications do so at their own risk and CDIL will not be responsible for any damages resulting from such sale(s).

CDIL strives for continuous improvement and reserves the right to change the specifications of its products without prior notice.



CDIL is a registered Trademark of

Continental Device India Limited

C-120 Naraina Industrial Area, New Delhi 110 028, India.

Telephone + 91-11-2579 6150, 4141 1112 Fax + 91-11-2579 5290, 4141 1119

email@cdil.com www.cdiseil.com