

CR22™

595mm x 595mm Architectural LED Troffer

Product Description

The CR22™ architectural LED troffer delivers up to 3200 lumens of exceptional 90+ CRI light while achieving 90 lumens per watt. This breakthrough performance is achieved by combining the high efficacy and high-quality light of Cree TrueWhite® Technology with a unique thermal management approach. The CR22 is available in warm or cool color temperatures and has both 1-10V and DALI dimming options. Its compact, lightweight design easily accommodates recessed, surface mount, or suspended installations, making the CR22 perfect for use in commercial new construction or retrofit applications.

Performance Summary

Utilizes Cree TrueWhite® Technology
Active Color Management
Room-Side Heat Sink
Efficacy: 90 LPW
Delivered Light Output: 2000, 3200 lumens
Input Power: 22, 35 watts
CRI: 90
CCT: 3000K, 4000K
Input Voltage: 220-240 VAC
Warranty: 5 Years †
Lifetime: Designed to last 50,000 hours
Dimming: 1-10V or DALI Dimming to 5%*
Mounting: Recessed
Dimensions: L 595mm x W 595mm x H 120mm
Weight: 7 Kg

CR22

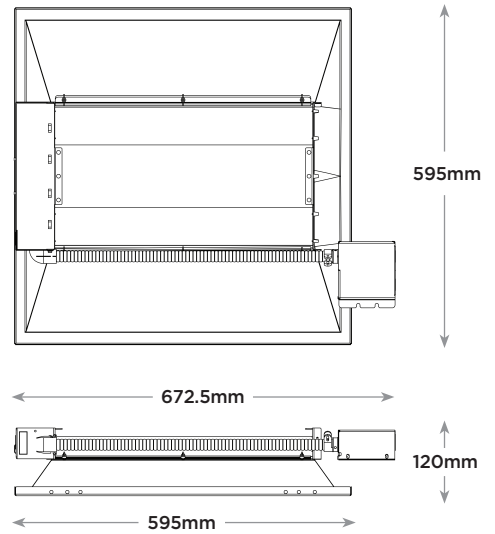
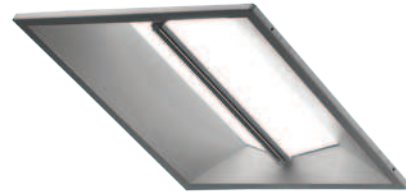

Ordering Information

Example: CR22-20L-40K-23

CR22					
Product	Lumen Output	Color Temperature	Control	Voltage	Options
CR22	20L 22W 2000 lumens - 90 LPW 32L 35W 3200 lumens - 90 LPW	30K 3000 Kelvin 40K 4000 Kelvin	Blank Non-dimming ADIM 1-10V Dimming to 5% DALI** DALI Dimming to 5%	23 220-240 Volt (Standard)	BLANK CE/CB certified CP CCC certified

† See www.cree.com/lighting/products/warranty for warranty terms.

* Reference www.cree.com/lighting for recommended dimming control options.

** DALI only available in 32L types.



Rev. Date 02/27/2013



Product Specifications

CREE TRUEWHITE® TECHNOLOGY

A revolutionary way to generate high-quality white light, Cree TrueWhite® Technology mixes the light from the highest performing red and unsaturated yellow LEDs. This patented approach delivers an exclusive combination of 90+ CRI, beautiful light characteristics, and lifelong color consistency, all while maintaining high luminous efficacy—a true no compromise solution.

ROOM-SIDE HEAT SINK

An innovative thermal management system designed to maximize cooling effectiveness by integrating a unique room-side heat sink into the diffusing lens. This breakthrough design creates a pleasing architectural aesthetic while conducting heat away from LEDs in a temperature-controlled environment. This enables the LEDs to consistently run cooler, providing significant boosts to lifetime, efficacy, and color consistency.

LUMEN MAINTENANCE FACTORS

- Reference www.cree.com/lighting for detailed lumen maintenance factors.

CONSTRUCTION & MATERIALS

- Durable 20-gauge steel housing with standard troffer access plate for electrical installation.
- Field replaceable light engine integrates LEDs, driver, power supply, thermal management, and optical mixing components.
- One-piece lower reflector finished with a textured high reflectance white polyester powder coating creates a comfortable visual transition from the lens to the ceiling plane.
- Provided t-bar clips and holes for mounting support wires enable recessed or suspended installation.
- Individual fixtures may be mounted end to end for a continuous row of illumination.

NOTE: Reference www.cree.com/lighting for detailed instructions on field replacement of the light engine.

OPTICAL SYSTEM

- Unique combination of reflective and refractive optical components achieves a uniform, comfortable appearance while eliminating pixelation and color fringing.
- Components work together to optimize distribution, balancing the delivery of high illuminance levels on horizontal surfaces with an ideal amount of light on walls and vertical surfaces. This increases the perception of spaciousness.
- Diffusing lens integrated with upward-facing LED strip eliminates direct view of LEDs while lower reflector balances brightness of lens with the ceiling to create a low-glare high angle appearance.

ELECTRICAL SYSTEM

- Integral, high-efficiency driver and power supply.
- Power Factor** = 0.9 nominal
- Input Power:** Stays constant over life.
- Input Voltage:** 220-240V, 50/60Hz
- Dimming:** Dimmable to 5% with Analog 1-10V or DALI control protocols. Reference www.cree.com/lighting for recommended dimming controls.
- Temperature Rating:** Designed to operate in temperatures 35 C and below room side and plenum side.
- Total Harmonic Distortion:** < 20%

REGULATORY & VOLUNTARY QUALIFICATIONS

- CE certified.
- CCC certified.
- IP23

Photometry

CR22 BASED ON LTL REPORT TEST #: 24292

Fixture photometry has been conducted by a NVLAP accredited testing laboratory in accordance with IESNA LM-79-08. IESNA LM-79-08 specifies the entire luminaire as the source resulting in a fixture efficiency of 100%.

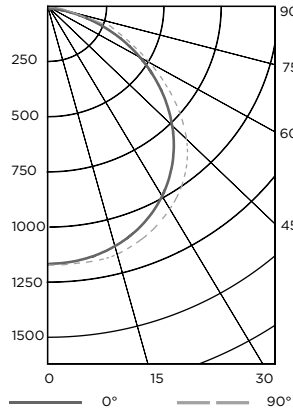

Coefficients Of Utilization

RCC %:	80			
RW %:	70	50	30	10
RCR: 0	119	119	119	119
1	110	105	101	98
2	100	92	85	80
3	91	81	73	67
4	84	72	63	57
5	77	64	55	49
6	71	58	49	43
7	66	52	44	38
8	61	48	39	33
9	57	44	36	30
10	53	40	32	27

Effective Floor Cavity Reflectance: 20%

Average Luminance Table (cd/m2)

		Horizontal Angle		
		0°	45°	90°
Vertical Angle	0°	3864	3864	3864
	45°	3575	3864	3972
	55°	3164	3656	3758
	65°	2498	3133	3347
	75°	1620	2348	2051
	85°	366	252	168

Zonal Lumen Summary

Zone	Lumens	% Lamp	Luminaire
0-30	923	N/A	28.1%
0-40	1527	N/A	46.5%
0-60	2704	N/A	82.5%
0-90	3280	N/A	100%

Reference www.cree.com/lighting for detailed photometric data.

Application Reference

Open Space					
Spacing (m)	Lumens	Wattage	LPW	w/m ²	Actual Lux
2.4 x 2.4	2000L	22W	90	3.76	305
	3200L	35W	90	5.91	480
2.4 x 3.0	2000L	22W	90	3.01	250
	3200L	35W	90	4.73	405
3.0 x 3.0	2000L	22W	90	2.37	435
	3200L	35W	90	3.76	340
3.0 x 3.6	2000L	22W	90	2.04	175
	3200L	35W	90	3.12	275

3m ceiling; 80/50/20 reflectances; 0.75m workplane, open room. LLF: 1.0 Initial. Open Space: 15m x 12m x 3m

