

# FMVCTC SERIES

5.0 Vdc VCTCXO

14 PIN DIP

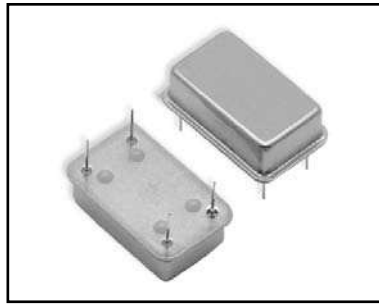

- 5.0 Vdc Supply Voltage
- HCMOS/TTL Compatible
- Clipped Sinewave
- Tight Stability Over Temp.



## SPECIFICATIONS

09 - Issue 2 - 020309

Parameter	HCMOS/TTL Spec.	Clipped Sinewave Spec.
Frequency Range	1.8432 - 48 MHz	10 - 48 MHz
Frequency Adjustment Range	±3 ppm min.	±3 ppm min.
Frequency Stability vs. Temp	See Table	See Table
Frequency Stability vs. Input V.	±0.5 ppm max.	±0.5 ppm max.
Frequency Stability vs. Load	±0.3 ppm max.	±0.3 ppm max.
Frequency Stability vs. Aging	±1 ppm per year max.	±1 ppm per year max.
Storage Temperature	-40 to +85°C	-40 to +85°C
Supply Voltage (Vdd)	+5.0 Vdc (±0.25 Vdc)	+5.0 Vdc (±0.25 Vdc)
Supply Current (Icc)	20 mA max	3 mA max.
Symmetry (Duty Cycle)	40/60% Std.	40/60% Std.
Output "0" Level (VOL)	0.4 Vdc max. (TTL) 0.5 Vdc max. (HCMOS)	1.0 Vp-p min.
Output "1" Level (VOH)	2.4 Vdc min. (TTL) 4.5 Vdc min. (HCMOS)	1.0 Vp-p min.
Rise and Fall Time	10 ns max.	10 ns max.
Output Load	10 TTL / 15 pF HCMOS	20 k ohms // 5 pF
Control Voltage (Vc)	2.5 Vdc ±2.0 Vdc Pos. Transfer	2.5 Vdc ±2.0 Vdc Pos.Trns.
Jitter (typical)	< 10 pico seconds, one sigma	
Phase Noise (typical)	10 Hz -75dBc/Hz 100 Hz -110dBc/Hz 1kHz -125dBc/Hz 10kHz -130dBc/Hz 100kHz -140dBc/Hz	
Aging @ 25°C	±1 ppm max first year	

All specifications subject to change without notice.

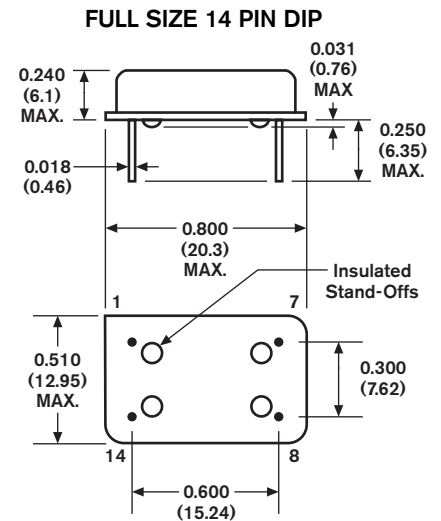

### PIN FUNCTION TABLE

Pin	Function
1	Control Voltage (Vc)
7	Case Ground
8	Output
14	Supply Voltage (Vdd)

### FREQUENCY STABILITY vs. TEMPERATURE AVAILABILITY TABLE

Temp. Range	FM Code	Frequency Stability (±ppm)												
		1.5	2.0	2.5	3.0	3.5	4.0	4.5	5.0	10.0	15.0			
0 to 50°C	J	*	*	*	*	*	*	*	*	*	*	*	*	*
-10 to 60°C	E	*	*	*	*	*	*	*	*	*	*	*	*	*
0 to 70°C	A		*	*	*	*	*	*	*	*	*	*	*	*
-20 to 70°C	B			*	*	*	*	*	*	*	*	*	*	*
-30 to 60°C	F				*	*	*	*	*	*	*	*	*	*
-40 to 85°C	C					*	*	*	*	*	*	*	*	*

\* Denotes Availability

### STANDARD MARKING

XXX.XXXM  
 XXXXXXX  
 • FMI YYWW

XXX.XXXM FREQUENCY in MHz  
 XXXXXXX Part Number  
 Pin 1 Symbol, FMI, Date Code

### Standard Specifications for product indicated in color

Dimensions:  $\frac{\text{Inches}}{\text{(mm)}}$

## PART DESCRIPTION SYSTEM

FMVCTC 050 A SW - XX.XXXXXXM - CM

