



# CyberDisplay® WQVGA LV

Part Numbers: KCD-QWNF-AA Frameless; KCD-QWNF-BA Framed



## FEATURES

- 428 x 240 x 3 dot active resolution (308,160 dots)
- 438 x 246 x 3 dot total resolution (321,768 dots)
- 5 μm (H) x 15 μm (V) dot pitch
- Ultra-compact (0.29" diagonal)
- Active pixel area (6.42 mm x 3.60 mm)
- Parallel RGB analog input
- Simple 3.3-volt interface for CMOS compatible driver chip
- 60-75 Hz frame rate
- Power-saving sleep mode
- Integrated low-voltage detect
- Integrated horizontal and vertical scanners
- Bidirectional horizontal and vertical scanning

BLOCK DIAGRAM

The CyberDisplay® WQVGA LV is a color-filter active-matrix liquid crystal display (AMLCD) with 308,160 (428 x 240 x 3) color dot resolution. The display utilizes high-performance single-crystal silicon transistors, and is the smallest (0.29" diagonal) transmissive AMLCD for the resolution. The transmissive CyberDisplay WQVGA LV with color filter has the same display architecture as the industry standard LCD monitor or TV. The ultra-compact CyberDisplay WQVGA LV is ideal for camcorder and digital camera viewfinders or entry-level portable consumer and industrial applications.

### Functional Description

The CyberDisplay WQVGA LV features Kopin's patent-pending low-voltage architecture for low power consumption and compatibility with CMOS driver ICs. Bidirectional horizontal and vertical scanner circuits are integrated. A sleep mode is provided to simplify system power management. The active array of 1284 x 240 dots is surrounded by opaque dummy pixels, for a total array size of 1308 x 246 dots.

The CyberDisplay WQVGA LV can be driven by the A220 or A221 controller IC.

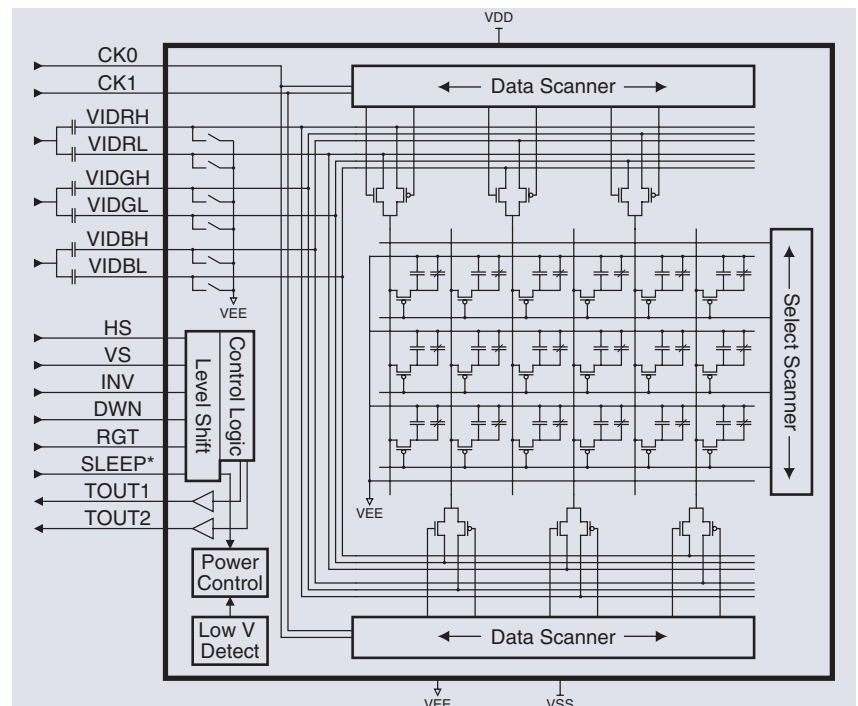

### DISPLAY MARKETING

Tel: 508-870-5959 Fax: 508-870-0660

### HONG KONG

Tel: 852-2607-4151 Fax: 852-2607-4156

### JAPAN

Tel: 81-3-5325-3549 Fax: 81-3-5322-2929

### KOREA

Tel: 82-31-337-2451 Fax: 82-31-335-7680

cyberdisplay@kopin.com

\*Specifications subject to change without notice

DS KCD-QWNF-AA Rev. A 8/3/06



# CyberDisplay® WQVGA LV

Part Numbers: KCD-QWNF-AA Frameless; KCD-QWNF-BA Framed

The Low Voltage

CyberDisplay® WQVGA LV

is an active-matrix liquid

crystal display with

428 x 240 x 3 color dot

resolution, arranged in

a 16 x 9 format.

PIXEL LAYOUT

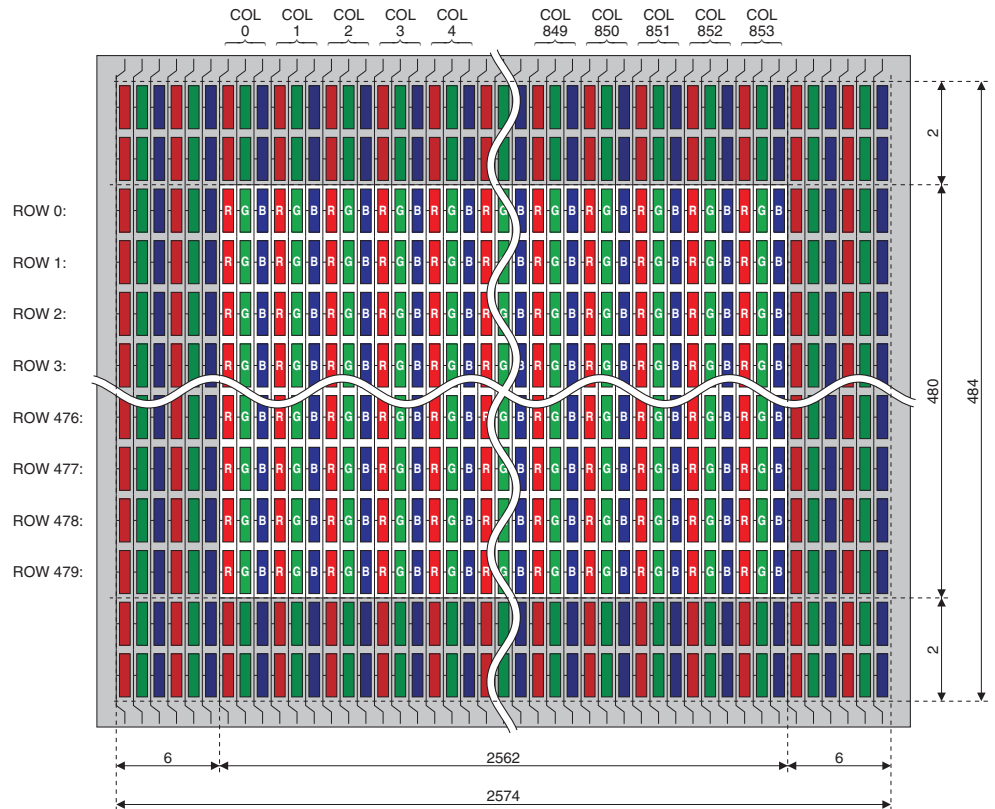

## ELECTRICAL

ITEM	TYPICAL
<b>POWER</b>	
Supply Interface	3.30 volt
Operating Current	0.4 mA
Operating Current Interface	100 µA
<b>OPERATING ENVIRONMENT</b>	
Temperature	-20°C to 60°C
<b>DIMENSIONS</b>	
Height*	6.00 mm
Width*	10.20 mm
Depth*	1.40 mm
Weight	0.28 grams
Flex Cable length	51.22 mm

\*Display die dimensions

## INTERFACE

PIN	SYMBOL	DESCRIPTION
1	VEE	Supply = 0V
2	VIDRH	High red video input
3	VIDGH	High green video input
4	VIDBH	High blue video input
5	VIDRL	Low red video input
6	VIDGL	Low green video input
7	VIDBL	Low blue video input
8	HS	Horizontal sync
9	VS	Vertical sync
10	INV	Inversion polarity
11	DWN	Vertical scan direction (H = top-to-bottom)
12	RGT	Horizontal scan direction (H = left-to-right)
13	SLEEP*	Sleep mode
14	CK0	Clock
15	CK1	Clock
16	VDD	Supply
17	VSS	Supply = -5V
18	TOUT1	Test output
19	TOUT2	Test output
20	VEE	Supply = 0V

\*Signal is active low