

FEATURES

- 1280 x 1024 x 3 dot active resolution (3,932,160 dots)
- 1288 x 1028 x 3 dot total resolution (3,972,192 dots)
- 5 μm (H) x 15 μm (V) dot pitch
- Ultra-compact (0.97" diagonal)
- Active pixel area (19.20 mm x 15.36 mm)
- Parallel RGB analog input
- Simple 3.3-volt interface for CMOS compatible driver chip
- 60-75 Hz frame rate
- Power-saving sleep mode
- Integrated low-voltage detect
- Integrated horizontal and vertical scanners
- Bidirectional vertical scanning

BLOCK DIAGRAM



The CyberDisplay® SXGA LV is a color-filter active-matrix liquid crystal display (AMLCD) with 3,932,160 (1280 x 1024 x 3) color dot resolution. The display utilizes high-performance single-crystal silicon transistors, and is the smallest (0.97" diagonal) transmissive AMLCD for the resolution. The transmissive CyberDisplay SXGA LV with color filter has the same display architecture as the industry standard LCD monitor or TV. The ultra-compact CyberDisplay SXGA LV is ideal for high end consumer or professional portable devices and industrial applications.

Functional Description

The CyberDisplay SXGA LV features Kopin's patent-pending low-voltage architecture for low power consumption and compatibility with CMOS driver ICs. Bidirectional vertical scanner circuits are integrated, along with a sleep mode. The active array of 3840 x 1024 dots is surrounded by opaque dummy pixels, for a total array size of 3864 x 1028 dots. Each full color square pixel is composed of three primary color dots.

The CyberDisplay SVGA LV can be driven by the A910 controller IC.

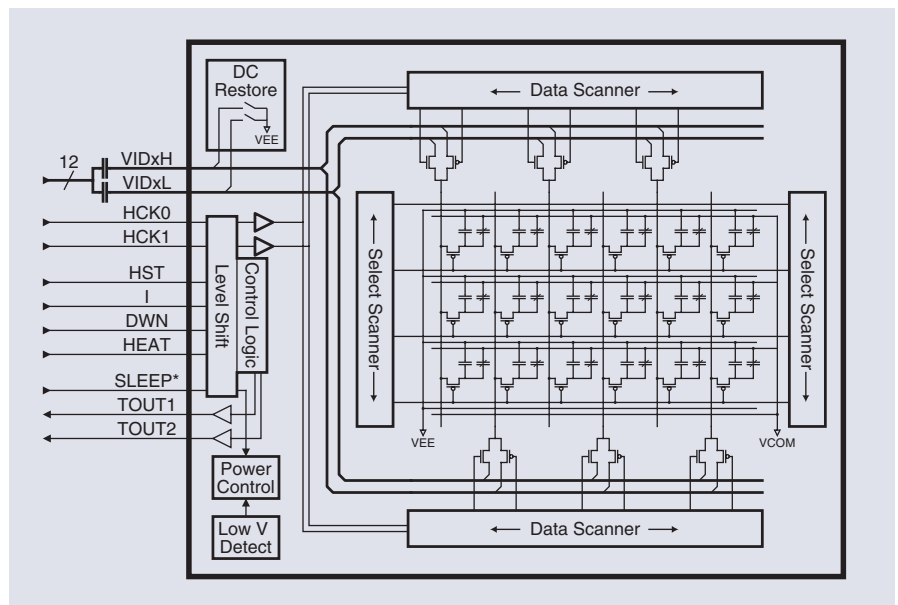

*Specifications subject to change without notice

DISPLAY MARKETING

Tel: 508-870-5959 Fax: 508-870-0660

HONG KONG

Tel: 852-2607-4151 Fax: 852-2607-4156

JAPAN

Tel: 81-3-5325-3549 Fax: 81-3-5322-2929

KOREA

Tel: 82-31-337-2451 Fax: 82-31-335-7680

cyberdisplay@kopin.com

The CyberDisplay®

SXGA LV is an active matrix liquid crystal display with 1280 x 1024 x 3 color dot resolution.

PIXEL LAYOUT

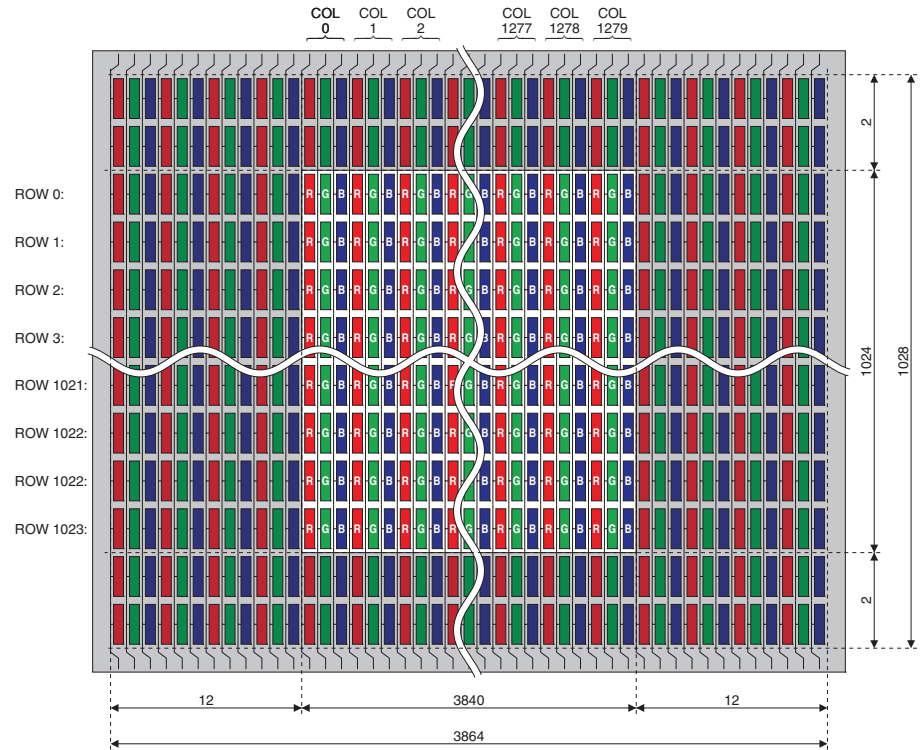

INTERFACE

PIN	SYMBOL	DESCRIPTION
1	VCOM	Pixel common electrode
2	VIDR0H	High video input
3	VIDG0H	High video input
4	VIDB0H	High video input
5	VIDR1H	High video input
6	VIDG1H	High video input
7	VIDB1H	High video input
8	VIDR2H	High video input
9	VIDG2H	High video input
10	VIDB2H	High video input
11	VIDR3H	High video input
12	VIDG3H	High video input
13	VIDB3H	High video input
14	VDD	Supply
15	VCC	Interface Supply
16	VSS	Supply
17	HCK0	Horizontal clock
18	HCK1	Horizontal clock
19	HST	Horizontal start
20	I	Instruction input

PIN	SYMBOL	DESCRIPTION
21	DWN	Vertical scan direction
22	SPR	Spare
23	SLEEP*	Sleep mode
24	VEE	Supply = 0V
25	VDD	Supply
26	VSS	Supply
27	VIDB3L	Low video input
28	VIDG3L	Low video input
29	VIDR3L	Low video input
30	VIDB2L	Low video input
31	VIDG2L	Low video input
32	VIDR2L	Low video input
33	VIDB1L	Low video input
34	VIDG1L	Low video input
35	VIDR1L	Low video input
36	VIDB0L	Low video input
37	VIDG0L	Low video input
38	VIDR0L	Low video input
39	TOUT0	Test output
40	TOUT1	Test output

*Signal is active low