

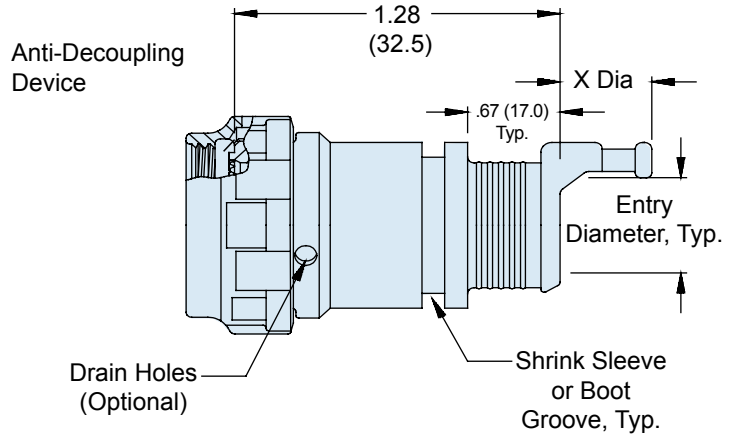

447-327 Composite Standard Profile EMI/RFI Banding Backshell with Qwik-Ty® Strain Relief and Self-Locking Rotatable Coupling

A

CONNECTOR DESIGNATOR:	
A	MIL-DTL-5015, -26482 Series II, and -83723 Series I and III
F	MIL-DTL-38999 Series I, II
L	MIL-DTL-38999 Series 1.5 (JN1003)
H	MIL-DTL-38999 Series III and IV
G	MIL-DTL-28840
U	DG123 and DG123A
SELF-LOCKING	
ROTATABLE COUPLING	
STANDARD PROFILE	

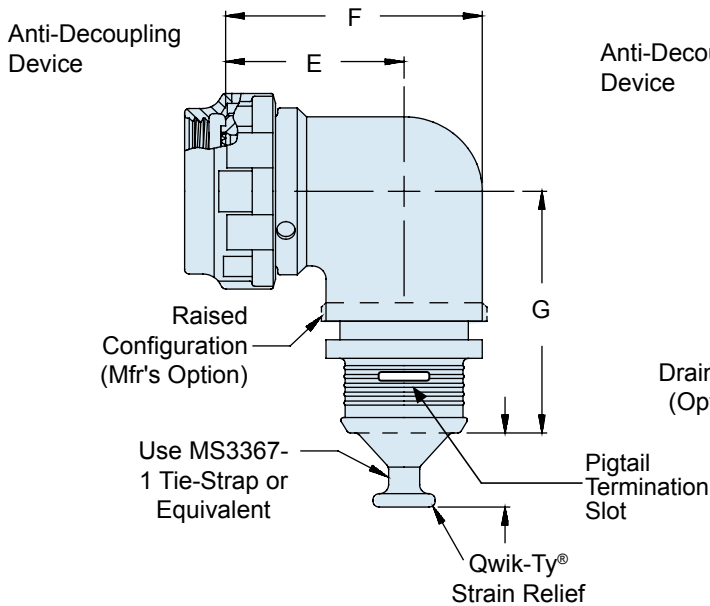
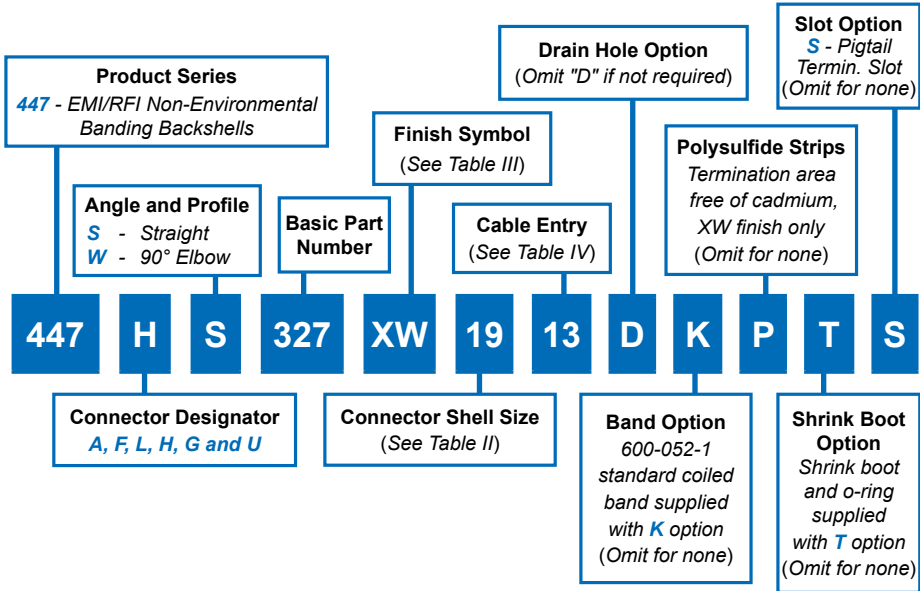

447-327
Composite Standard Profile EMI/RFI
Banding Backshell with Qwik-Ty® Strain Relief
and Self-Locking Rotatable Coupling

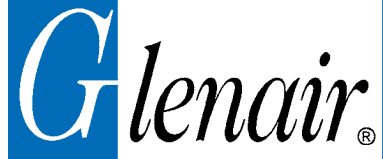

TABLE II: CONNECTOR SHELL SIZE

Shell Size For												
Connector Designator*					E		F		G		Max Entry	
A	F/L	H	G	U	±.06	(1.5)	±.09	(2.3)	±.09	(2.3)	Dash No**	
08	08	09	—	—	.69	(17.5)	.88	(22.4)	1.36	(34.5)	04	
10	10	11	—	08	.75	(19.1)	1.00	(25.4)	1.42	(36.1)	05	
12	12	13	11	10	.81	(20.6)	1.13	(28.7)	1.48	(37.6)	07	
14	14	15	13	12	.88	(22.4)	1.31	(33.3)	1.55	(39.4)	09	
16	16	17	15	14	.94	(23.9)	1.38	(35.1)	1.61	(40.9)	11	
18	18	19	17	16	.97	(24.6)	1.44	(36.6)	1.64	(41.7)	13	
20	20	21	19	18	1.06	(26.9)	1.63	(41.4)	1.73	(43.9)	15	
22	22	23	—	20	1.13	(28.7)	1.75	(44.5)	1.80	(45.7)	17	
24	24	25	23	22	1.19	(30.2)	1.88	(47.8)	1.86	(47.2)	20	

**Consult factory for additional entry sizes available.

TABLE III: FINISH

Symbol	Finish Description
XM	2000 Hour Corrosion Resistant Electroless Nickel
XMT	2000 Hour Corrosion Resistant Ni-PTFE, Nickel-Fluorocarbon Polymer. <i>1000 Hour Grey™</i>
XW	2000 Hour Corrosion Resistant Cadmium/Olive Drab over Electroless Nickel

TABLE IV: CABLE ENTRY

Entry Code	Entry Dia. ±.03 (0.8)	X Dia. ±.03 (0.8)
04	.250 (6.4)	.510 (13.0)
05	.310 (7.9)	.510 (13.0)
07	.440 (11.2)	.510 (13.0)
09	.560 (14.2)	.630 (16.0)
11	.680 (17.3)	.630 (16.0)
13	.810 (20.6)	.630 (16.0)
15	.940 (23.9)	.630 (16.0)
16	1.000 (25.4)	.630 (16.0)
17	1.160 (29.5)	.630 (16.0)
20	1.250 (31.8)	.630 (16.0)

NOTES

1. 770-001S**-0 shrink boot supplied with T option. See shrink boot product page for more details.
2. O-Ring will not be supplied with Connector Designator A.
3. Consult factory for O-ring to be supplied with part less shrink boot.
4. Metric dimensions (mm) are in parenthesis and are for reference only.
5. Coupling nut supplied unplated.
6. See Table I in Intro for front-end dimensional details.