



713-379

Hat Trick System Composite Junction Box Adapter with Banding and Boot Platform For Series 74 Helical Plastic Conduit

Hat Trick System Composite junction box adapter for Series 74 conduit with EMI/ environmental banding and boot platform

Master Keyway Clocking

Master keyway angle for angular assemblies is measured with adapter body as shown.

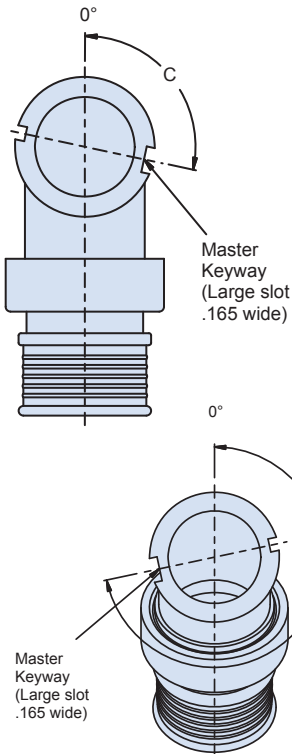

How To Order

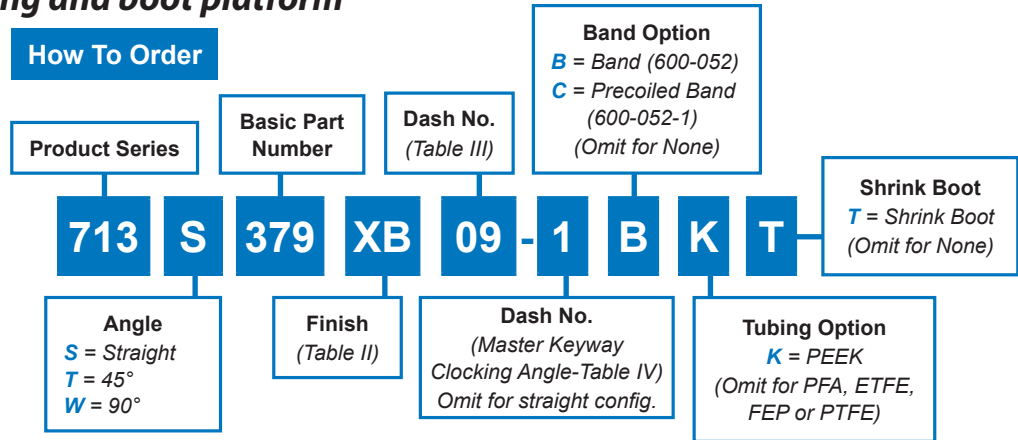

Dash No	Tubing I.D. Nom	B Dia	Shrink Boot
06	.188 (4.8)	.481 (12.2)	770-001S103
09	.281 (7.1)	.575 (14.6)	770-001S104
10	.312 (7.9)	.611 (15.5)	770-001S104
12	.375 (9.5)	.671 (17.0)	770-001S104
14	.437 (11.1)	.732 (18.6)	770-001S104
16	.500 (12.7)	.811 (2.6)	770-001S105
20	.625 (15.9)	.931 (23.6)	770-001S106
24	.750 (19.1)	1.091 (27.7)	770-001S106
28	.875 (22.2)	1.234 (31.3)	770-001S107
32	1.000 (25.4)	1.382 (35.1)	770-001S107

Symbol	Finish Description
XMT	PTFE - Gray (1000 hr. salt spray)
XM	Electroless Nickel
XW	Cadmium Olive Drab over Electroless Nickel
XB	Black color/unplated

Dash No	G
1	0°
2	30°
3	45°
19	45°
20	135°
21	180°
22	225°
23	315°

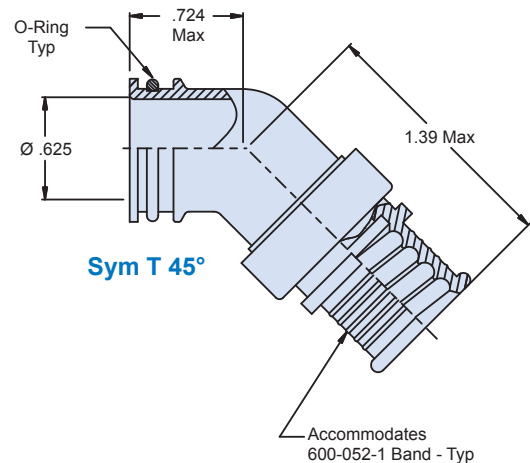
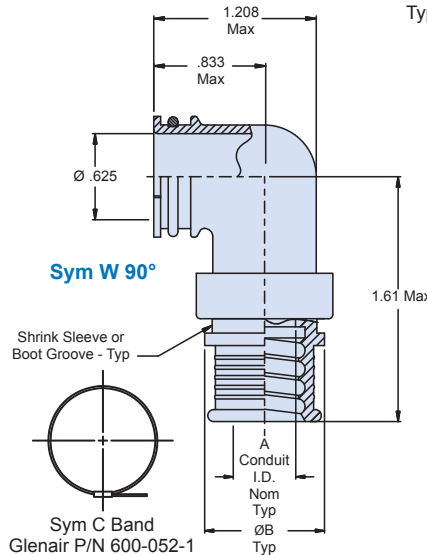
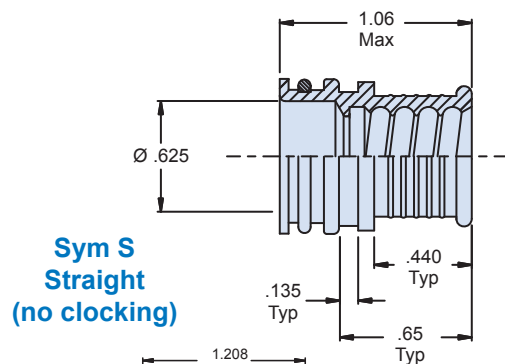

Material/Finish

- Elbow, adapter: High grade engineering thermoplastic, black/table II
- O-Ring: silicone/NA