

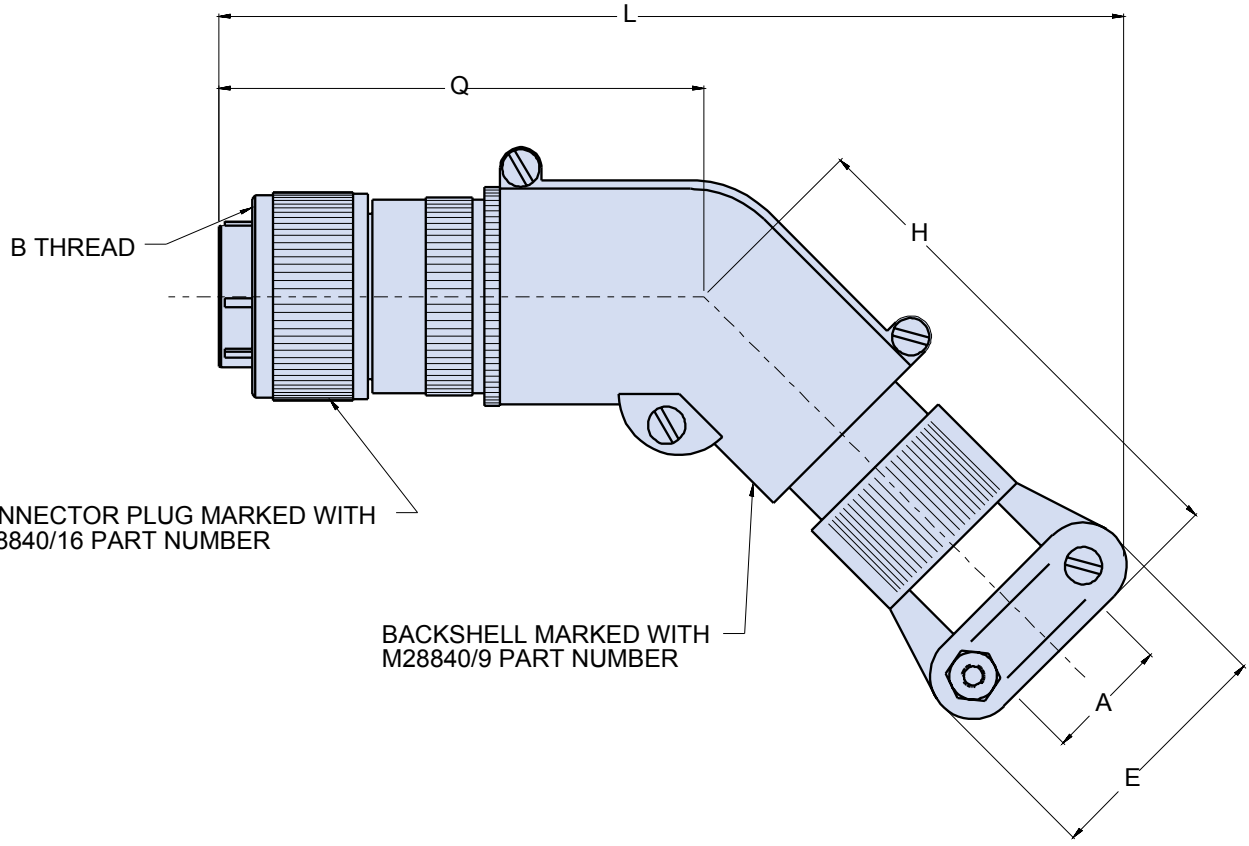

M28840/29
Plug Connector
with 45° EMI/RFI Backshell

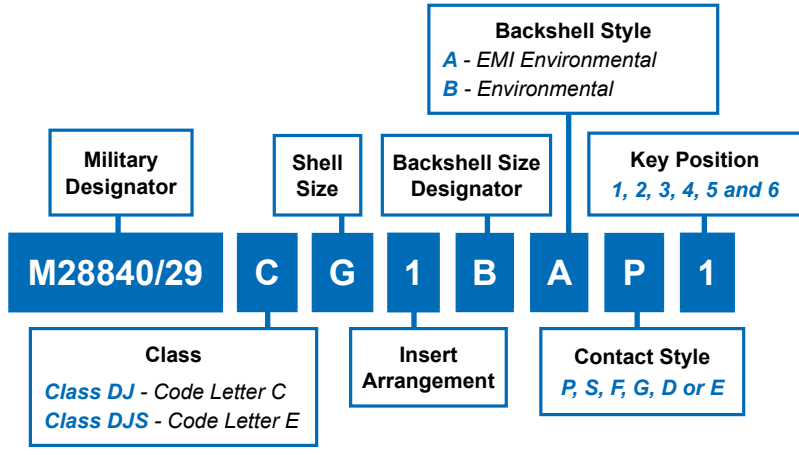

Dimensions in Inches (millimeters) are subject to change without notice.

**M28840/29
Plug Connector
with 45° EMI/RFI Backshell**



J Military Shell Size	Shell Size	Backshell Size Designator	A Cable Entry		A Thread Class 2B	E Max.	H Max.	L Max.	Q Max.
			Open	Closed					
A	11	A	.312	.188	.750-1P-.2L-DS	.938	5.432	7.404	3.250
A	11	B	.438	.281		1.125	5.432	7.457	3.250
A	11	C	.562	.344		1.312	5.557	7.727	3.375
B	13	A	.438	.281	.875-1P-.2L-DS	1.125	5.432	7.457	3.250
B	13	B	.562	.344		1.312	5.557	7.727	3.375
B	13	C	.625	.375		1.312	5.682	7.938	3.500
C	15	A	.438	.281	1.062-1P-.2L-DS	1.125	5.557	7.671	3.375
C	15	B	.562	.344		1.312	5.557	7.727	3.375
C	15	C	.625	.375		1.312	5.682	7.938	3.500
C	15	D	.750	.438		1.593	5.713	8.058	3.500
D	17	A	.625	.375	1.125-1P-.2L-DS	1.312	5.682	7.938	3.500
D	17	B	.750	.438		1.593	5.713	8.058	3.500
E	19	A	.625	.375	1.312-1P-.2L-DS	1.312	5.682	7.938	3.500
E	19	B	.938	.625		1.750	5.932	8.371	3.625
F	23	A	.750	.438	1.500-1P-.2L-DS	1.593	5.838	8.272	3.625
F	23	B	.938	.625		1.750	5.932	8.371	3.625
F	23	C	1.188	.812		2.093	6.119	8.628	3.625
G	25	A	.938	.625	1.625-1P-.2L-DS	1.750	5.932	8.371	3.625
G	25	B	1.188	.812		2.093	6.119	8.628	3.625
G	25	C	1.250	.875		2.093	6.244	8.841	3.750
G	25	D	1.380	1.000		2.343	6.276	8.950	3.750
H	29	A	1.188	.812	1.812-1P-.2L-DS	2.093	6.244	8.841	3.750
H	29	B	1.380	1.000		2.343	6.276	8.950	3.750
J	33	A	1.380	1.000	2.000-1P-.2L-DS	2.343	6.526	9.377	4.000
J	33	B	1.625	1.250		2.750	6.801	9.659	4.000

Dimensions in Inches (millimeters) are subject to change without notice.

