

### SIZE #8 COAXIAL CONTACTS FOR M17/095-RG-180 CABLE



**Fig. 1**  
Pin Contact  
852-007-08-367



**Fig. 2**  
Socket Contact  
852-006-08-366

Coax contacts accept M17/095-RG180 cable. These snap-in, rear release contacts fit Glenair Series 80 Mighty Mouse connectors and Glenair MIL-DTL-38999 Series I, III and IV connectors with size #8 cavities. Crimp termination. Gold-plated copper alloy, Teflon insulator. Supplied unassembled.. Order sealing boot separately (fig. 3). 1 A. current rating, 500 Vac. SAE AS39029 qualified.

Fig.	Description	Cable Accommodation	Part Number	AS39029 Part Number	Color Bands		
					1st	2nd	3rd
Fig.1	Pin	M17/095-RG180	<a href="#">852-007-08-367</a>	M39029/60-367	Orn	Blu	Vio
Fig.2	Socket	M17/095-RG180	<a href="#">852-006-08-366</a>	M39029/59-366	Orn	Blu	Blu
Fig.3	Sealing Boot	M17/095-RG180	<a href="#">859-042-02</a>				

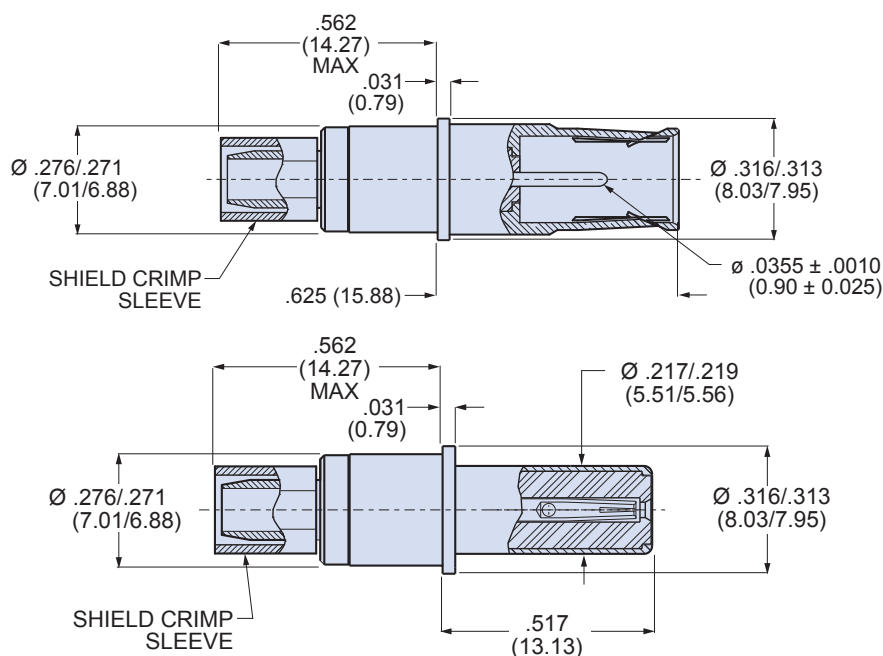

### CONTACT REMOVAL TOOL

Plastic tool extracts wired contact from connector. First, remove sealing boot, then insert tool from rear of connector.

Size	Part Number	Military Part Number
#8	<a href="#">859-049</a>	M81969/14-12



### SEALING BOOT

Sealing boot is ordered separately. Slide boot onto wire before terminating contact. After contact is installed in connector, slide boot forward into connector grommet to seal the contact cavity.

Wire Dia. (in.)	Wire Dia. (mm.)	Part Number
.090 - .130	2.3 - 3.3	<a href="#">859-042-01</a>
.130 - .170	3.3 - 4.3	<a href="#">859-042-02</a>
.170 - .205	4.3 - 5.2	<a href="#">859-042-03</a>

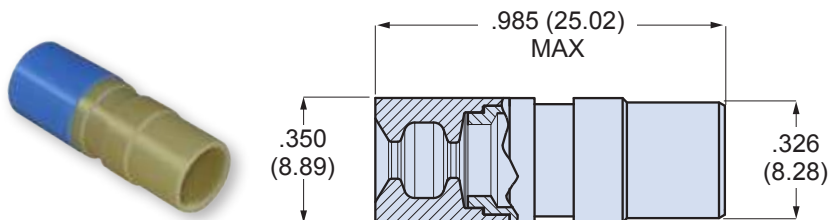

Dimensions in inches (millimeters) and are subject to change without notice.

CAGE Code 06324

Printed in U.S.A.

# Mighty Mouse Connectors with Size #8 Quadrax, Twinax, Coax or Power Contacts Size #8 Coax Contacts for RG180 Cable



## MATERIAL AND FINISH

Inner Contact, Outer Contact, Inner Ferrule, Crimp Sleeve	Copper alloy, 50 microinches gold over nickel
Insulator	Teflon
Sealing Boot Rigid Dielectric	Ultem
Sealing Boot Grommet	Fluorosilicone

## SPECIFICATIONS

Current Rating	1 ampere
Contact Resistance, Inner Contact	120 millivolt max. voltage drop @ 1 ampere
Contact Resistance – Outer Contact	60 millivolt max. voltage drop @ 12 amperes
Dielectric Withstanding Voltage	1300 Vrms Sea Level, 250 Vrms at 50,000 feet
Temperature Range	-65°C to +200°C
Durability	500 mating cycles
Corrosion	EIA-364-26, condition B, 48 hours
Vibration	EIA-364-28, condition V, letter J, 37g's
Shock	EIA-364-27, condition D, 300g's

## TERMINATION TOOLS FOR SIZE #8 COAX CONTACTS FOR RG-180 CABLE



**A** M22520/2-01 crimper for inner contact. Requires **B** positioner, ordered separately. Length is 6.75 inches, weight is approx. 10 oz.

**B** Positioner, M22520/2-31. Use with **A** crimper, ordered separately. Positioner holds contact at proper depth.

**C** Parallel action tool terminates intermediate contact and outer shield ferrule. Use with **D** hex crimp dies. 11 inches OAL, 2.0 pounds. Anodized aluminum frame, steel mechanism, plastic handles. Accepts all M22520/5 die sets.

**D** Die set for terminating intermediate contact and cable shield. Two closures—.218(5.54) hex closure for cable shield and Requires **C** crimp tool sold separately. Hardened steel, black oxide finish.

Figure	Part Number	Military Part Number	Daniels Part Number
A	<a href="#">809-015</a>	M22520/2-01	AFM8
B	<a href="#">859-050</a>	M22520/2-31	K406
C	<a href="#">809-129</a>	M22520/5-01	HX4
D	<a href="#">859-051</a>	M22520/5-05	Y197

## ABOUT SEALING BOOTS

The sealing boot is necessary to prevent moisture and contamination from penetrating the connector. The sealing boot is ordered separately. The boot consists of a rigid dielectric sleeve and a fluorosilicone rubber grommet. Slide boot onto cable before terminating contact. After the contact is installed into connector, seat the boot into connector grommet.

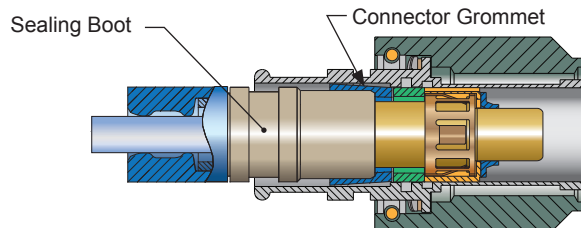

Dimensions in inches (millimeters) and are subject to change without notice.