

Glenair®



VG95328 Qualified Bayonet-Lock Connectors

*High-Density MIL-C-26482 Type Connectors—VG95328
Qualified for Rugged Military and Industrial Applications*

United States ■ United Kingdom ■ Germany ■ France ■ Nordic ■ Italy ■ Spain ■ Japan

Now Arriving on Track 5015!

Glenair Series ITS

Reverse Bayonet Connectors



EU Sales: Glenair Connectors Italia, S.r.L. Tel: +39-02-91082121 Email: sales-italia@glenair.com

North American Sales: Glenair Connecticut, Tel: 203-741-1115 Email: sales@glenair.com

Factory Support: Commital S.p.a. (Italy) Tel: +39-51-7821811 Email: commital@commital.com

United States • United Kingdom • Germany • Nordic • France • Italy • Spain

www.glenair.com

A World of Interconnect Solutions

VG95328
High Performance Crimp Contact
Bayonet-Lock Signal Connectors (MIL-C-26482 Type)



Qualified VG95328 Connector and Backshell Products for High Performance Military and Industrial Applications

Harsh Application Environments

The Glenair Series VG95328 Bayonet-Lock Signal Connector is ideally suited for all general and environmental applications that require a high-performance military type cylindrical connector with crimp-removable contacts. Qualified to VG95328, the bayonet mechanism provides fast and easy coupling, especially when the connector is situated in an awkward or hard to reach location.

Environmental protection to IP67 levels provides additional reliability and the flexibility to specify these rugged connectors in harsh

applications such as in machine tools and factory automation. Supplied crimp contacts are gold-plated copper alloy. Inserts are made from high-insulation synthetic rubber, oil and temperature resistant to -55°C to $+125^{\circ}\text{C}$.

Intermateability

The Series VG95328 Connector is interchangeable and intermateable with the wide range of industry-standard bayonet connectors designed around MIL-C-26482 and/or qualified to VG 95328.

- *High Performance Crimp Version with Contact Retention Clips and Sealed Inserts*
- *Environmental and Hermetic Versions*
- *2 Contact Sizes: #20 and #16.*
- *Closed Entry Socket Contacts*
- *18 Signal Contact Insert Arrangements, 3 to 61 Contacts*
- *Rear-Insertion/Front Release Snap-In Contacts*
- *Intermateable with Other MIL-C-26482 Products*
- *Ruggedized Contact Retention Clip*
- *Environmentally Sealed System*
- *Audible and Visual Coupling Indicators*
- *Keyed Polarization*
- *Optional Grounding Fingers on Plugs*



VG95328

Glenair's qualified VG95328 miniature bayonet-lock connector series is based on the MIL-C-26482 Series I standard, and shares the same insert arrangements, shell dimensions, supported contacts and electrical performance ratings as MIL-C-26482 and Glenair's commercial equivalent product line, the IPT SE. The VG 95328 3-point bayonet coupling mechanism provides easy mating and positive locking resistance to vibration, shock, and other connector de-coupling forces in general duty and environmental interconnect systems such as military and commercial aircraft, medical equipment, industrial controls, factory robotics, instrumentation and other general electronic applications.

Component Materials

VG95328 connectors are available in aluminum alloy and are supplied standard with an olive green cadmium finish IAW QQ-P-416. Supplied crimp contacts are gold plated copper alloy. Insulators are High Insulation Synthetic Rubber (Chloroprene): $-55^{\circ}\text{C}/+125^{\circ}\text{C}$.

EMI and Environmental Applications

VG95328 Series connectors are perfectly suited for use in rugged applications where EEC compliance directives for electromagnetical compatibility is required. A complete range of EMI shield termination accessories are available for both overall as well as individual wire shields.

Equipped with the appropriate backshells and environmental sealing, the connectors are submersible for 48 hours up to a depth of two meters.



Connector Accessories

Many of the VG95328 Series connectors come standard already paired with selected backshell accessories for most application requirements. See the accessory descriptions on the opposite page for more information. A full range of additional connector accessories including dustcaps and EMI gaskets are also available.

Please contact the factory for additional information or any of our worldwide sales and engineering facilities. Glenair's website, www.glenair.com also has complete information on these products, as well as other ruggedized power and signal connectors.

VG95328 offers a simplified ordering and part number format that combines the five standard connector shell styles with the most popular backshells and connector accessories. Available connector shell styles, backshell types and accessories include:

VG95328 Connector Shell Styles

- *Front Panel Mount Square Flange Receptacle with Accessory Threads*
- *Rear Box Mount Square Flange Receptacle with No Accessory Threads*
- *Rear Box Mount Square Flange Through Bulkhead Receptacle*
- *Straight Plug Connector with Accessory Threads*
- *Rear Box Mount Jam Nut Receptacle*

VG95328 Integrated Backshell Types

Type N Backshell for general-duty applications. This connector-backshell assembly is supplied with a general-duty backshell for the attachment of additional accessories such as MS 3057 cable clamps (ordered separately).

Types A, C and D: Backshell for general-duty environmental applications using unjacketed wire bundles. Additional environmental sealing is provided through an individual wire sealing grommet in the connector and an overall cable grommet seal in the backshell. No cable clamp supplied.

Types B, E and K Same as class above, but with cable clamp and bushing for strain-relief.

Types J, S and V Backshell for Heat Shrink Boot.

Types M, R and T Plug with backshell for EMI shield termination and/or heatshrink boot.

VG95328 Accessories

- *Plug and receptacle protective covers with various lanyard styles for panel attachment*
- *Plug and receptacle covers with various lanyard styles for cable attachment*
- *Conductive and non-conductive gaskets for panel mount connectors*
- *Dummy stowage receptacles*
- *Consult factory for additional products*



VG95328 Bayonet-Lock High Performance Crimp Contact Connector Materials and Finishes

The Glenair VG95328 miniature bayonet-lock connector series features a 3 point bayonet coupling mating interface with stainless steel coupling pins for advanced durability. Resilient closed entry inserts provide outstanding dielectric performance and environmental protection. Individual wire sealing grommets elevate the environmental protection rating to IP67. Conductive metal shells and plating provide a reliable ground plane for EMI applications when connectors are combined with appropriate shield termination backshells. Ground springs are also available in selected plug versions to further enhance EMC. Shells are keyed with five total alternate key positions. Connector shells are supplied standard in aluminum alloy with cadmium/olive drab passivation. For other plating options please consult Glenair's commercial equivalent catalog, *IPT and IPT SE Bayonet Lock Connectors*. The connectors are temperature rated from -55°C to +125°C (see opposite page for current ratings versus temperature). The VG95328 family consists of:

- 20 styles of connectors
- 9 Sizes of Connectors
- 2 Contact Sizes: #20 and #16
- 18 Insert Arrangements
- 2 Kinds of Contacts: Crimp Contacts (Standard); Solder Contacts (Hermetic Versions)

MATERIALS	
SHELLS	INSERTS (Temperature Range)
Aluminum Alloy IAW QQ-A-591 Shells	High Insulation Synthetic Rubber (Chloroprene): -55°C/+125°C
Stainless Steel Coupling Pins	CRIMP CONTACTS
Stainless Steel Spring	Copper Alloy with Gold Plating Over Nickel

STANDARD FINISH (For QQ-A-591 Aluminum Shells)	
Requirements	Cadmium with Olive Drab Passivation IAW QQ-P-416
Thermal Shock	-55°C + 125°C
Salt Spray After Thermal Shock	500 hour
Electical Conductivity	Very Good
Abrasion Resistance	Very Good

VG95328 Bayonet-Lock High Performance Crimp Contact Connector Technical Data



Service Rating			
Class	Operating voltage AC	Operating voltage DC	Test voltage AC
I	600	700	1500
II	1000	1250	2300

Potential Drop		
Contact size	Test current	Potential drop
20	7.5 A	25 mV
16	13.0 A	21 mV

Rated Current Versus Temperature

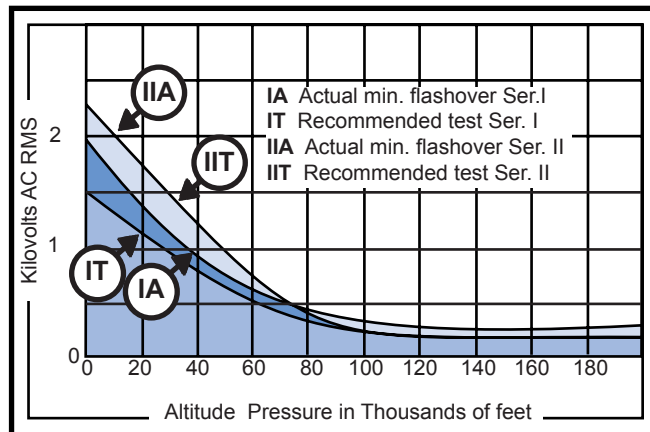
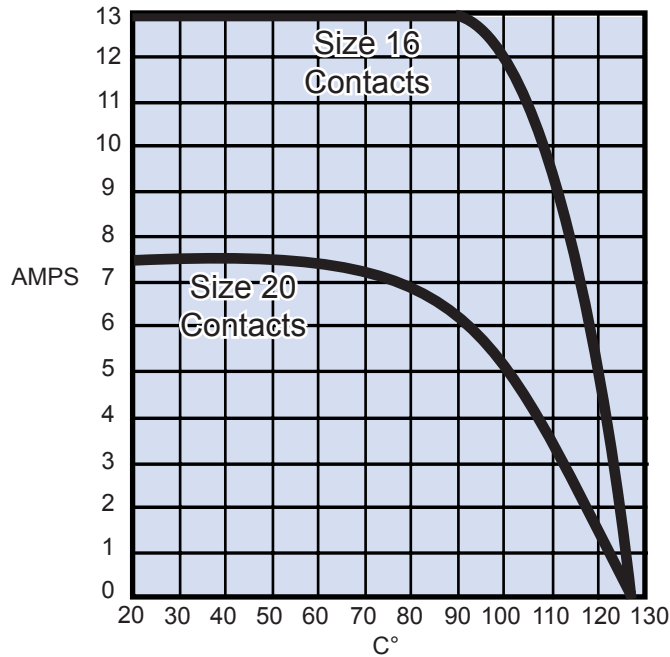



**VG95328 Bayonet-Lock
High Performance Crimp Contact (MIL-C-26482 Type)
How to Order • Cross Reference**

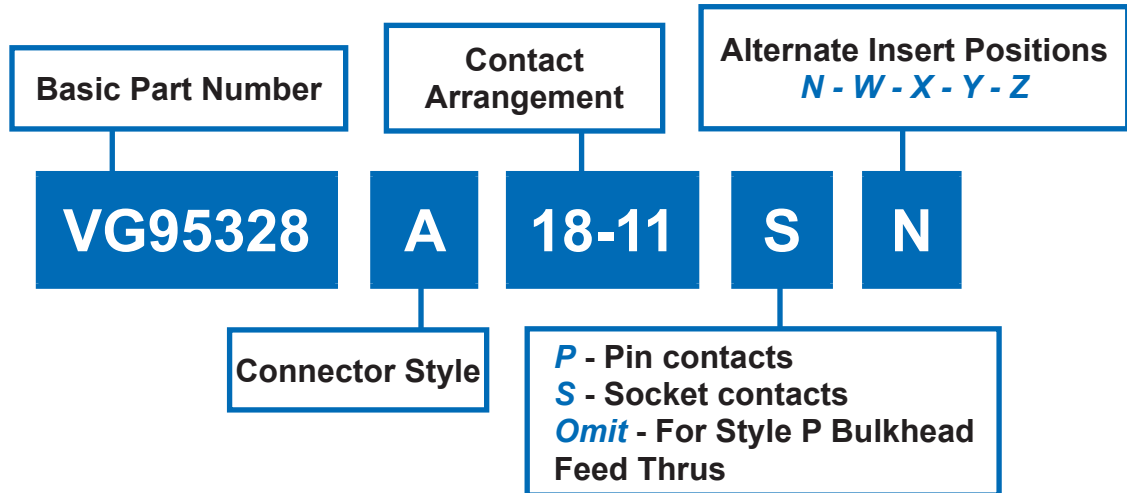

Connector Cross Reference		
VG95328 Connectors	MS	Glenair
VG95328 A	MS 3120 E	IPT 00 SE
VG95328 B	MS 3120 F	IPT 00 SE ... SR
VG95328 C	MS 3122 E	IPT 02 SE
VG95328 D	MS 3124 E	IPT 07 SE
VG95328 E	MS 3124 F	IPT 07 SE ... SR
VG95328 F	N.A.	N. A.
VG95328 G	N.A.	N. A.
VG95328 H	MS 3112 E	IPT 02 E
VG95328 J	N.A.	IPT 06 GSE
VG95328 K	MS 3126 F	IPT 06 SE ... SR
VG95328 L	N.A.	N. A.
VG95328 M	N.A.	IPT G 06 MSE
VG95328 N	N.A.	IPT G 06 ASE
VG95328 P	MS 3119 E	IPT 02 PP
VG95328 R	N.A.	IPT 00 MSE
VG95328 S	N.A.	IPT 07 GSE
VG95328 T	N.A.	IPT 07 MSE
VG95328 U	N.A.	N. A.
VG95328 V	N.A.	IPT G 06 GSE
VG95328 W	N.A.	N. A.

Accessory Cross Reference		
VG95328 Accessories	MS	Glenair
VG95328 Z1 A	MS 3181 C	IPT 3181 C
VG95328 Z1 B	N.A.	IPT 3181 CF
VG95328 Z1 C	N.A.	N. A.
VG95328 Z2 A	MS 3180 C	IPT 3180 C
VG95328 Z2 B	N.A.	IPT 3180 CF
VG95328 Z2 C	N.A.	N. A.
VG95328 Z3 C	N.A.	IPT 3181 NF
VG95328 T07 A	N.A.	10-101949
VG95328 T07 B	N.A.	10-101949 S
VG95328 T07 C	MS 3115	IPT 3115
VG95328 T07 D	N.A.	N. A.

Glenair IPT SE Commercial Equivalent Product Line



Glenair offers a complete commercial equivalent product line, the Series IPT SE, that conforms exactly to the VG95328 standard but also offers additional connector styles, backshell types, plating codes and other enhancements. For complete product information see the *IPT and IPT SE Bayonet-Lock Connector Catalog*.

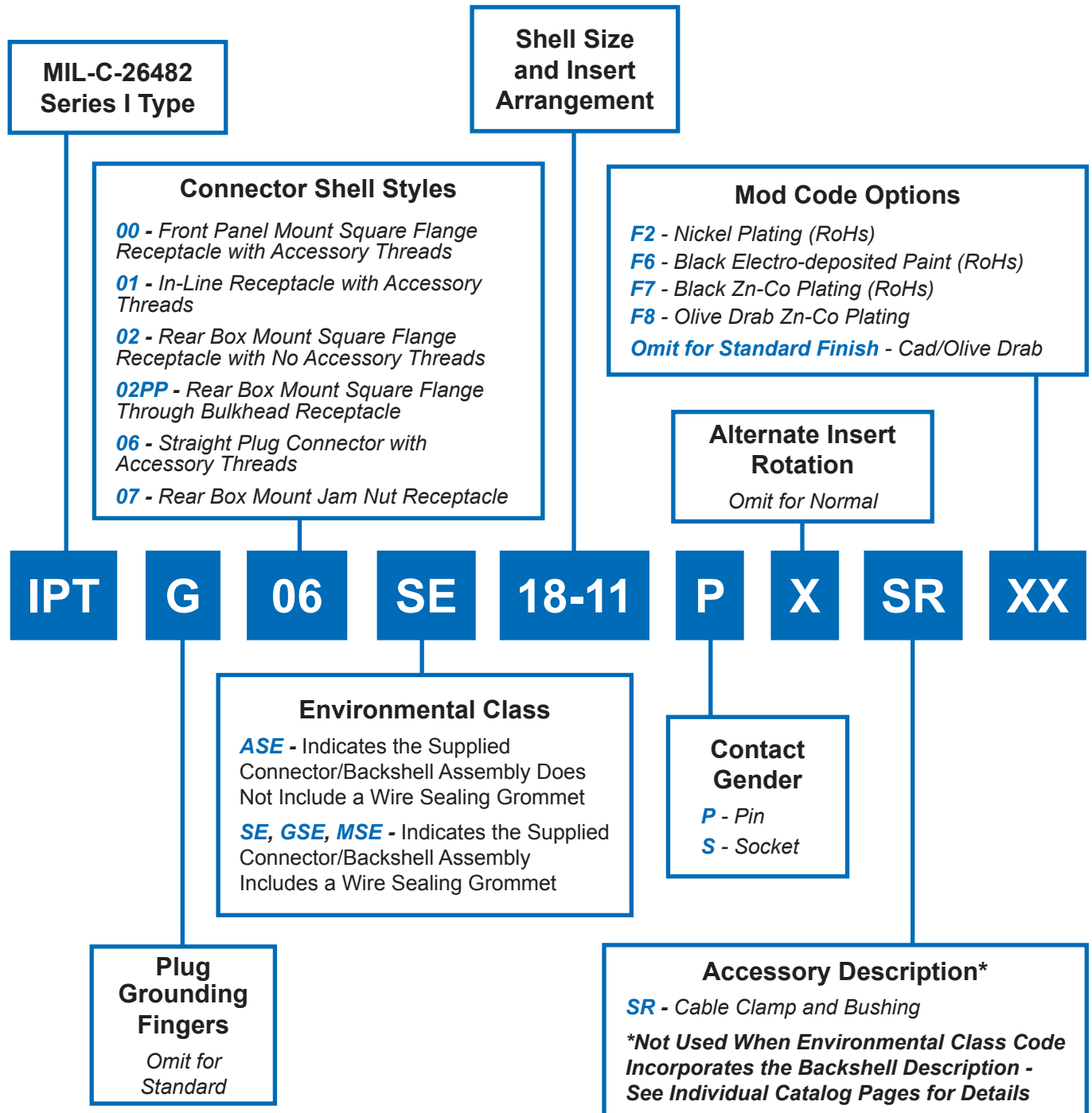

VG95328 Bayonet-Lock Connectors Solder Contacts for Hermetic Styles F, G and H Plus Crimp Contact Assembly Tools

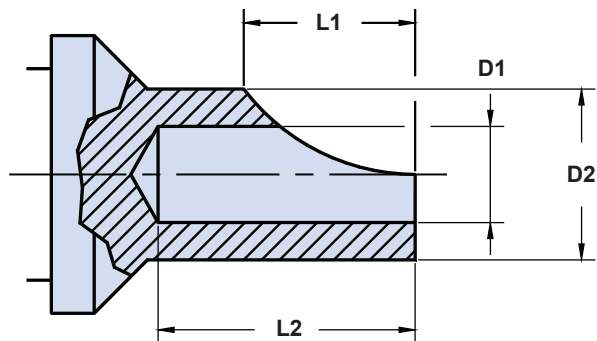

Termination Dimensions						
Contact size	D1 min.	D2 min.	Max.	L1 +1.5 -0.4	L2 ±0.8	Color
20	1.1	1.5	2.2	3.2	2.4	Red
16	1.8	2.4	2.9	4.8	3.2	Blue

VG95328 Crimp Connector Assembly Tools										
Contact Size	Wires Cross Section	Manual Crimping Tool	Pneumatic Crimping Tool	Turret	Insertion Tool	Removal Tool	mm ²		AWG	
							mm ²	AWG	mm ²	AWG
10-314980-20P										
10-314980-20S							20	20	M.105001 [AF8]	M.105003 [WA27F]
10-314980-16P										
10-314980-16S							16	16	M.105001 [AF8]	M.105003 [WA27F]

DMC Part Numbers indicated in [parentheses]

**VG95328 Bayonet-Lock Connectors
Crimp Contact Dimensions
Pin and Socket**

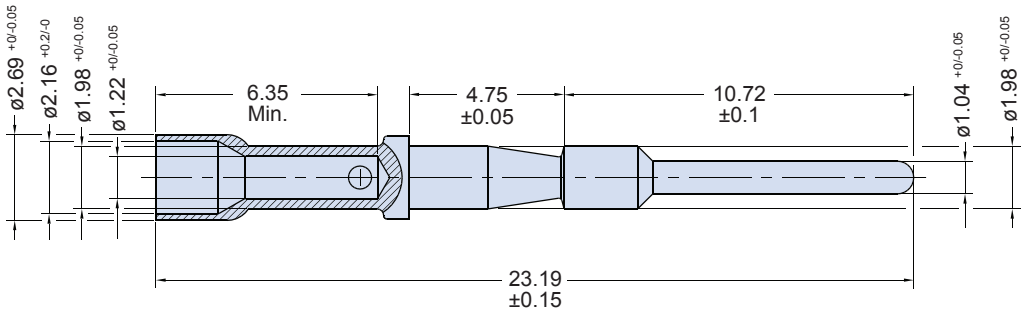

**Size 20 Pin Contact
10-314980-20P**

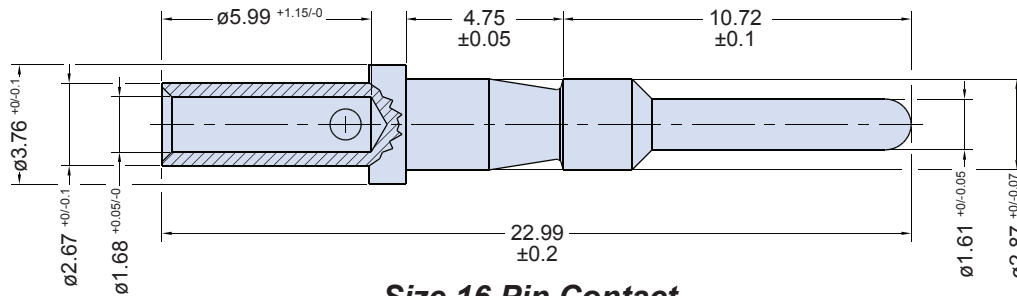

**Size 16 Pin Contact
10-314980-16P**

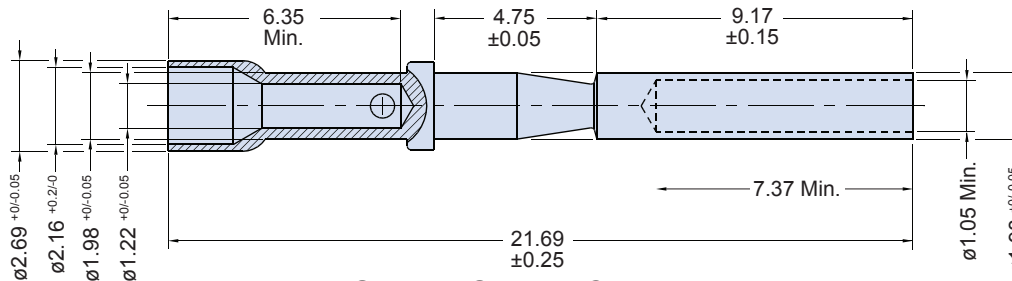

**Size 20 Socket Contact
10-314980-20S**

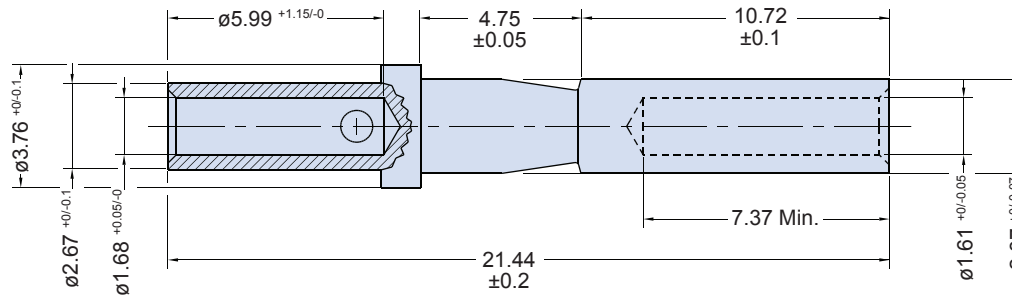

**Size 16 Socket Contact
10-314980-16S**

Sealing Plugs for Socket Cavity

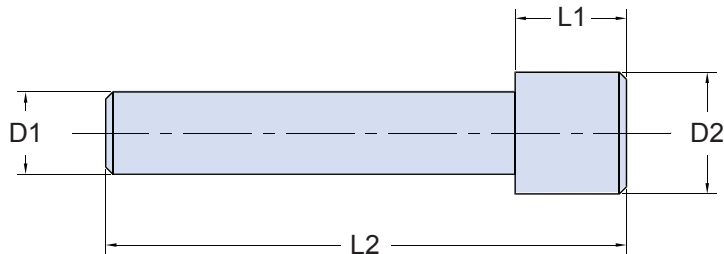

SEALING PLUG DIMENSIONS					
Part Number	D1 ±0.1	D2 ±0.2	L1 ±0.1	L2 ±0.3	Color
DIN 65194-20	1.62	2.3	3.5	14.5	Red
DIN 65194-16	2.30	3.4	3.1	14.5	Blue

Arrangement	Cl. Isol. Rating	Dim. contact size	
		20	16
8 - 3A	I	3	
10 - 6	I	6	
12 - 3	II		3
12 - 10	I	10	
14 - 5	II		5
14 - 12	I	8	4
14 - 15	I	14	1
14 - 19	I	19	
16 - 8	II		8
16 - 23	I	22	1
16 - 26	I	26	
18 - 11	II		11
18 - 32	I	32	
20 - 16	II		16
20 - 41	I	41	
22 - 21	II		21
22 - 55	I	55	
24 - 61	I	61	

Arrangement	Degrees			
	W	X	Y	Z
8 - 3A	60	(120)		
10 - 6	90			
12 - 3			180	
12 - 10	60	155	270	295
14 - 5	40	92	184	273
14 - 12	43	90		
14 - 15	17	110	155	234
14 - 19	30	165	315	
16 - 8	54	152	180	331
16 - 23	158	270		
16 - 26	60		275	338
18 - 11	62	119	241	340
18 - 32	85	138	222	265
20 - 16	238	318	333	347
20 - 41	45	126	225	
22 - 21	16	135	175	349
22 - 55	30	142	226	314
24 - 61	90	180	270	324

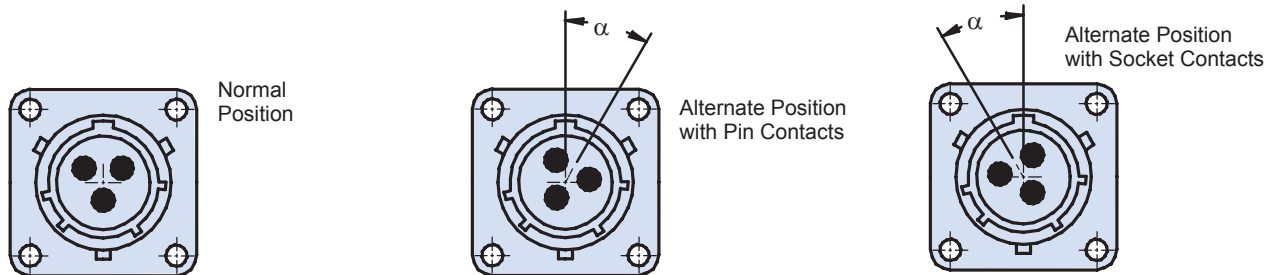

VG95328 Available Insert Arrangements



3 Contacts

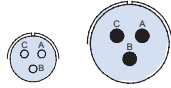

Arrangement:	8-3A	12-3
Contact Size:	20	16
Service Rating:	I	II

6 Contacts



Arrangement:	10-6
Contact Size:	20
Service Rating:	I

10 Contacts



Arrangement:	12-10
Contact Size:	20
Service Rating:	I

12 Contacts

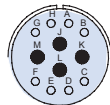

Arrangement:	14-12
Contact Size:	8-20, 4-16
Service Rating:	I

16 Contacts

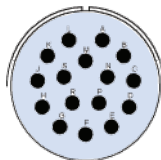

Arrangement:	20-16
Contact Size:	16
Service Rating:	II

5 Contacts

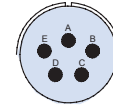

Arrangement:	14-5
Contact Size:	16
Service Rating:	II

8 Contacts

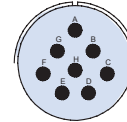

Arrangement:	16-8
Contact Size:	16
Service Rating:	II

11 Contacts

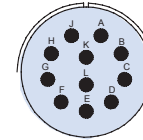

Arrangement:	18-11
Contact Size:	16
Service Rating:	II

15 Contacts

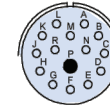

Arrangement:	14-15
Contact Size:	14-20, 1-16
Service Rating:	I

19 Contacts

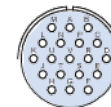

Arrangement:	14-19
Contact Size:	20
Service Rating:	I

Contact Legend



20



16

*Consult Factory

21 Contacts

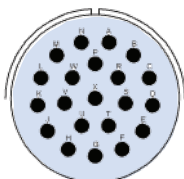

Arrangement:	22-21*
Contact Size:	16
Service Rating:	II

26 Contacts

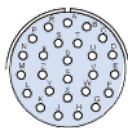

Arrangement:	16-26
Contact Size:	20
Service Rating:	I

41 Contacts

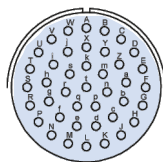

Arrangement:	20-41
Contact Size:	20
Service Rating:	I

61 Contacts

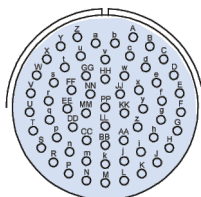

Arrangement:	24-61
Contact Size:	20
Service Rating:	I

23 Contacts

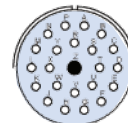

Arrangement:	16-23
Contact Size:	22-20, 1-16
Service Rating:	I

32 Contacts

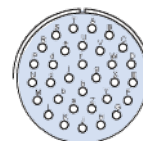

Arrangement:	18-32
Contact Size:	20
Service Rating:	I

55 Contacts

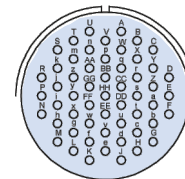

Arrangement:	22-55
Contact Size:	20
Service Rating:	I

Contact Legend



20



16

*Consult Factory

VG95328 Bayonet-Lock High Performance Crimp (MIL-C-26482 Type) Fastener Height Requirements and Panel Cutout Dimensions



For front panel mount square flange connectors the "A" dimension indicates the measured maximums that mounting hardware can stand proud from the connector flange before it will interfere with connector mating. For rear box mount square flange connectors the same "A" column maximum dimensions apply, but in this case the measurement taken includes the thickness of the panel wall or box (so the mounting hardware needs to be correspondingly shorter). Column "A1" defines the maximums for the bulkhead feedthrough product before mounting hardware interferes with mating.

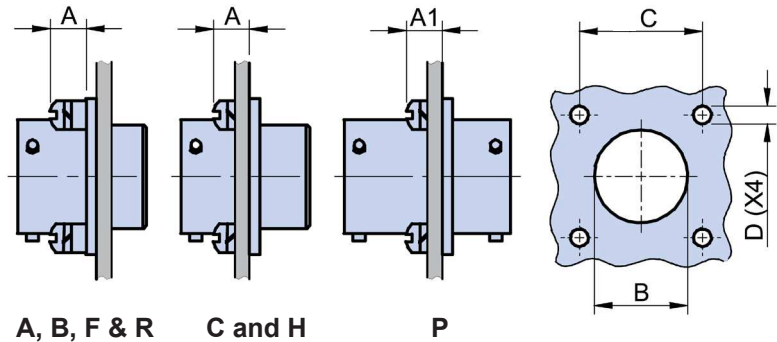

Panel Thickness and Panel Cutout for Square Flange Mount Receptacles					
Shell size	A max	A1 max	B +0.2 -0	C ±0.1	D ±0.12
8	2.2	5.54	15.1	15.10	3.04
10	2.2	5.54	18.3	18.25	3.04
12	2.2	5.54	20.6	20.60	3.04
14	2.2	5.54	23.0	23.00	3.04
16	2.2	5.54	24.6	24.60	3.04
18	2.2	5.54	27.0	27.00	3.04
20	5.4	8.74	29.4	29.35	3.04
22	5.4	8.74	31.8	31.75	3.04
24	5.4	7.9	34.9	34.90	3.73

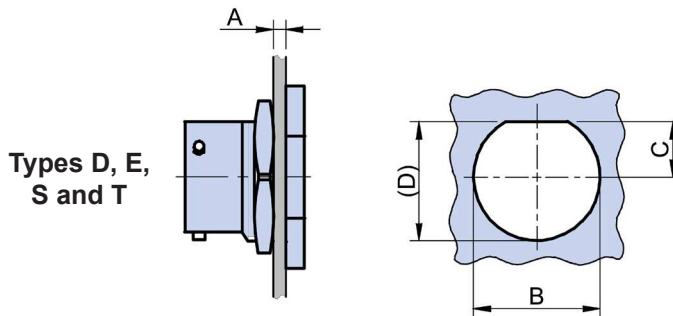

Panel Thickness and Panel Cutout for Jam Nut Mount Receptacles				
Shell size	A min - max	B +0.25 -0	C +0 -0.25	D
8	1.6 - 3.2	14.5	6.55	13.8
10	1.6 - 3.2	17.7	8.15	17.0
12	1.6 - 3.2	22.5	9.85	21.1
14	1.6 - 3.2	25.6	11.50	24.3
16	1.6 - 3.2	28.8	13.10	27.5
18	1.6 - 3.2	32.0	14.70	30.7
20	1.6 - 6.3	35.2	16.30	33.9
22	1.6 - 6.3	38.3	17.95	37.1
24	1.6 - 6.3	41.5	19.25	40.0

VG95328 A
Bayonet-Lock
Front Panel Mount Square Flange Receptacle
with Backshell

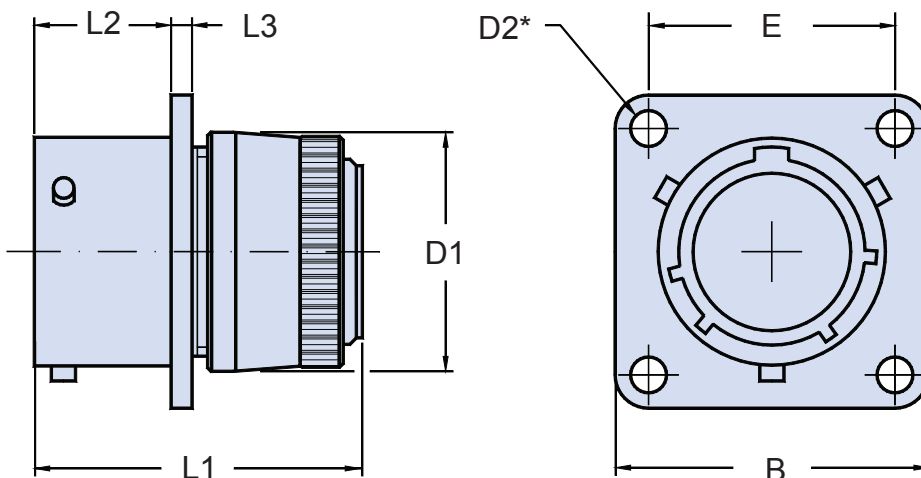
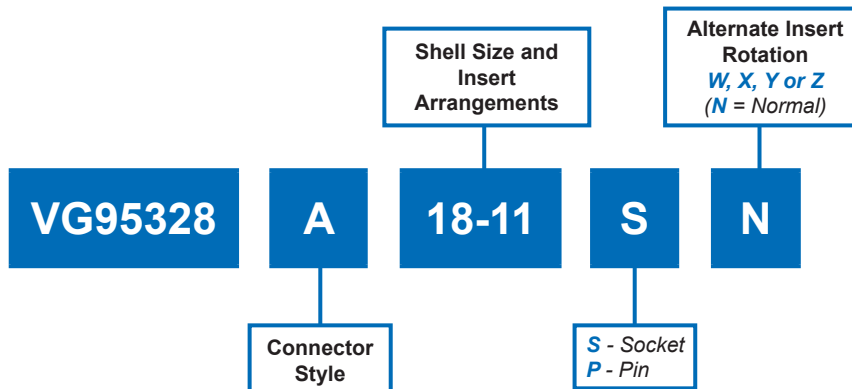

TABLE I: DIMENSIONS

Shell Size	B Max.	D1 Max.	D2 * Min.	E ±0.15	L1 Max.	L2 + 0.8 - 0	L3 Max.	Maximum Weight in Grams
8	21.03	15.44	2.9	15.08	40	10.94	2.0	10
10	24.23	18.64	2.9	18.26	40	10.94	2.0	14
12	26.59	21.79	2.9	20.62	40	10.94	2.0	22
14	28.98	25.00	2.9	23.01	40	10.94	2.0	29
16	31.34	28.19	2.9	24.61	40	10.94	2.0	37
18	33.73	31.34	2.9	26.97	40	10.94	2.0	45
20	36.90	34.54	2.9	29.36	44	14.12	2.8	50
22	40.08	37.69	2.9	31.75	44	14.12	2.8	55
24	43.25	40.89	3.6	34.92	44	14.86	2.8	65

* Through Mounting Holes

VG95328 A Bayonet-Lock Front Panel Mount Square Flange Receptacle with Backshell



VG95328
Connectors

Contact Arrangements			
Arrangement	Cl. Isol. Rating	Dim. contact size	
		20	16
8 - 3A	I	3	
10 - 6	I	6	
12 - 3	II		3
12 - 10	I	10	
14 - 5	II		5
14 - 12	I	8	4
14 - 15	I	14	1
14 - 19	I	19	
16 - 8	II		8
16 - 23	I	22	1
16 - 26	I	26	
18 - 11	II		11
18 - 32	I	32	
20 - 16	II		16
20 - 41	I	41	
22 - 21	II		21
22 - 55	I	55	
24 - 61	I	61	

Alternate Insert Orientations				
Arrangement	Degrees			
	W	X	Y	Z
8 - 3A	60	(120)		
10 - 6	90			
12 - 3			180	
12 - 10	60	155	270	295
14 - 5	40	92	184	273
14 - 12	43	90		
14 - 15	17	110	155	234
14 - 19	30	165	315	
16 - 8	54	152	180	331
16 - 23	158	270		
16 - 26	60		275	338
18 - 11	62	119	241	340
18 - 32	85	138	222	265
20 - 16	238	318	333	347
20 - 41	45	126	225	
22 - 21	16	135	175	349
22 - 55	30	142	226	314
24 - 61	90	180	270	324

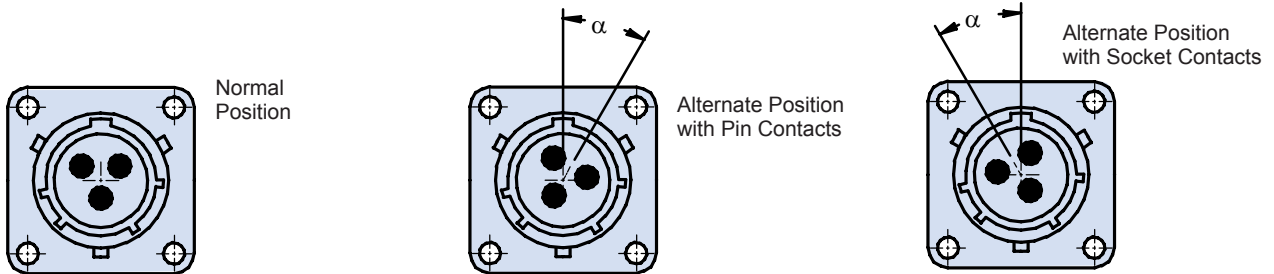

MATERIALS	
SHELLS	INSERTS (Temperature Range)
Aluminum Alloy IAW QQ-A-591 Shells	High Insulation Synthetic Rubber (Chloroprene): -55°C/+125°C
Stainless Steel Coupling Pins	CRIMP CONTACTS
Stainless Steel Spring	Copper Alloy with Gold Plating Over Nickel

STANDARD FINISH (For QQ-A-591 Aluminum Shells)	
Requirements	Cadmium with Olive Drab Passivation IAW QQ-P-416
Thermal Shock	-55°C + 125°C
Salt Spray After Thermal Shock	500 hour
Electrical Conductivity	Very Good
Abrasion Resistance	Very Good

See Page 13 for Panel Thickness and Cutout Dimensions

VG95328 B
Bayonet-Lock
Front Panel Mount Square Flange Receptacle
with Backshell, Cable Clamp and Bushing

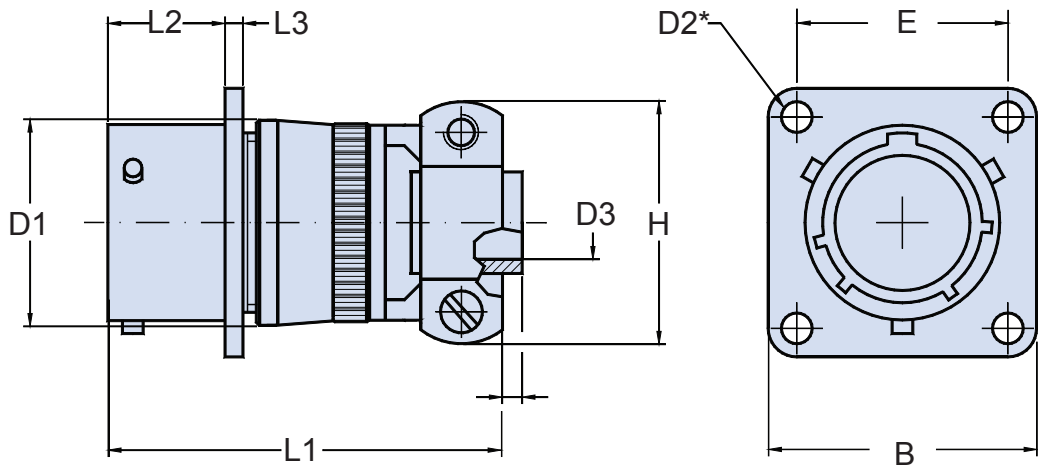
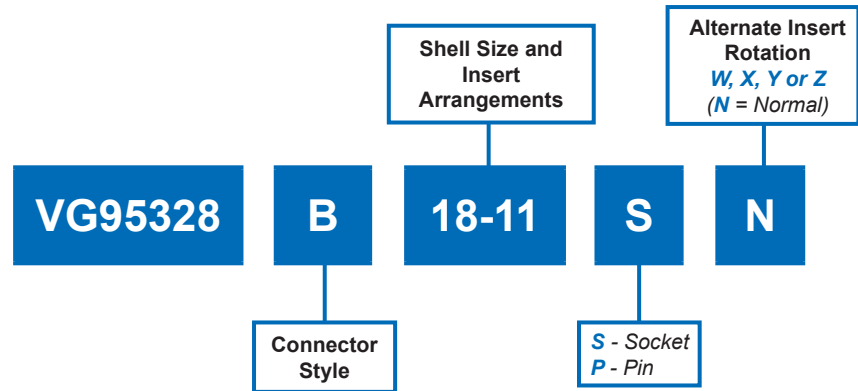

TABLE I: DIMENSIONS

Shell size	B Max.	D1 Max.	D2 * Min.	D3 + 0.3 - 0.7	E ±0.15	H Max.	L1 Max.	L2 + 0.8 - 0	L3 Max.	Maximum Weight in Grams
8	21.03	15.44	2.9	3.2	15.08	21.1	61.5	10.94	2.0	20
10	24.23	18.64	2.9	4.8	18.26	22.7	61.5	10.94	2.0	22
12	26.59	27.79	2.9	7.9	20.62	25.9	61.5	10.94	2.0	29
14	28.98	25.00	2.9	9.5	23.01	29.0	61.5	10.94	2.0	40
16	31.34	28.19	2.9	12.7	24.61	30.6	64.4	10.94	2.0	51
18	33.73	31.34	2.9	15.9	26.97	37.4	64.4	10.94	2.0	62
20	36.90	34.54	2.9	15.9	29.36	37.4	71.1	14.12	2.8	70
22	40.08	37.69	2.9	19.1	31.75	42.1	71.1	14.12	2.8	75
24	43.25	40.89	3.6	20.3	34.92	44.5	73.6	14.96	2.8	87

* Through Mounting Holes

VG95328 B Bayonet-Lock Front Panel Mount Square Flange Receptacle with Backshell, Cable Clamp and Bushing



VG95328
Connectors

Contact Arrangements			
Arrangement	Cl. Isol. Rating	Dim. contact size	
		20	16
8 - 3A	I	3	
10 - 6	I	6	
12 - 3	II		3
12 - 10	I	10	
14 - 5	II		5
14 - 12	I	8	4
14 - 15	I	14	1
14 - 19	I	19	
16 - 8	II		8
16 - 23	I	22	1
16 - 26	I	26	
18 - 11	II		11
18 - 32	I	32	
20 - 16	II		16
20 - 41	I	41	
22 - 21	II		21
22 - 55	I	55	
24 - 61	I	61	

Alternate Insert Orientations				
Arrangement	Degrees			
	W	X	Y	Z
8 - 3A	60	(120)		
10 - 6	90			
12 - 3			180	
12 - 10	60	155	270	295
14 - 5	40	92	184	273
14 - 12	43	90		
14 - 15	17	110	155	234
14 - 19	30	165	315	
16 - 8	54	152	180	331
16 - 23	158	270		
16 - 26	60		275	338
18 - 11	62	119	241	340
18 - 32	85	138	222	265
20 - 16	238	318	333	347
20 - 41	45	126	225	
22 - 21	16	135	175	349
22 - 55	30	142	226	314
24 - 61	90	180	270	324

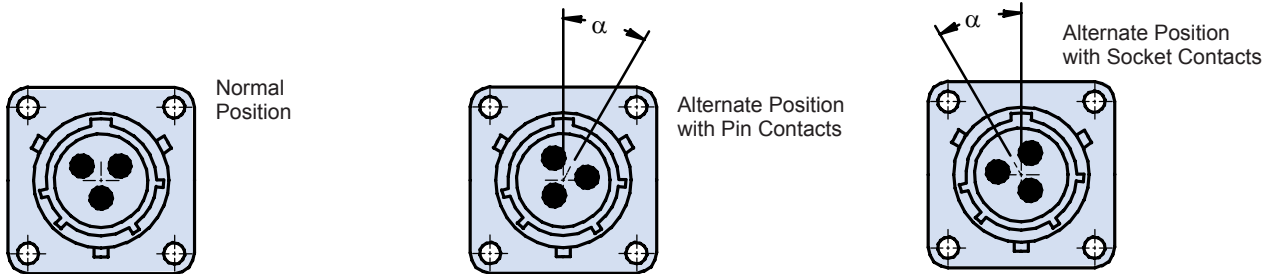

MATERIALS	
SHELLS	INSERTS (Temperature Range)
Aluminum Alloy IAW QQ-A-591 Shells	High Insulation Synthetic Rubber (Chloroprene): -55°C/+125°C
Stainless Steel Coupling Pins	CRIMP CONTACTS
Stainless Steel Spring	Copper Alloy with Gold Plating Over Nickel

STANDARD FINISH (For QQ-A-591 Aluminum Shells)	
Requirements	Cadmium with Olive Drab Passivation IAW QQ-P-416
Thermal Shock	-55°C + 125°C
Salt Spray After Thermal Shock	500 hour
Electical Conductivity	Very Good
Abrasion Resistance	Very Good

See Page 13 for Panel Thickness and Cutout Dimensions

VG95328 C
Bayonet-Lock
Rear Box Mount Square Flange Receptacle

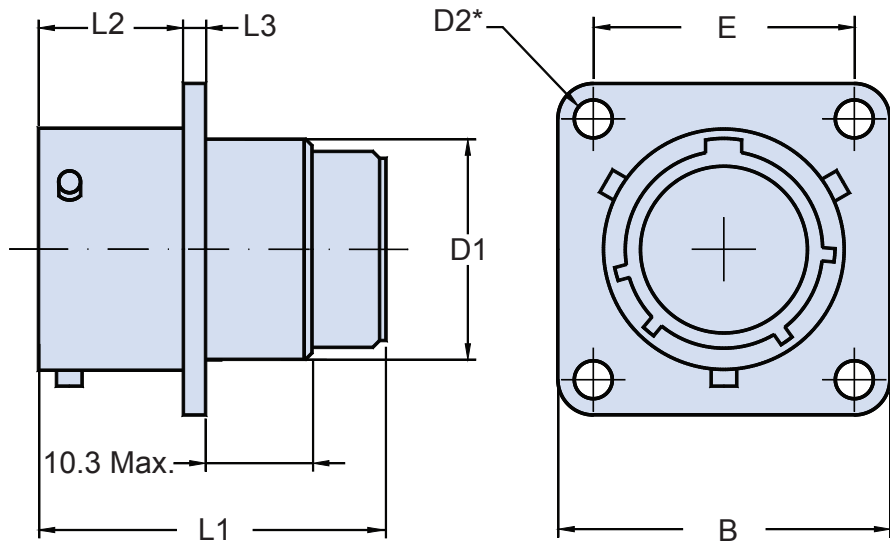
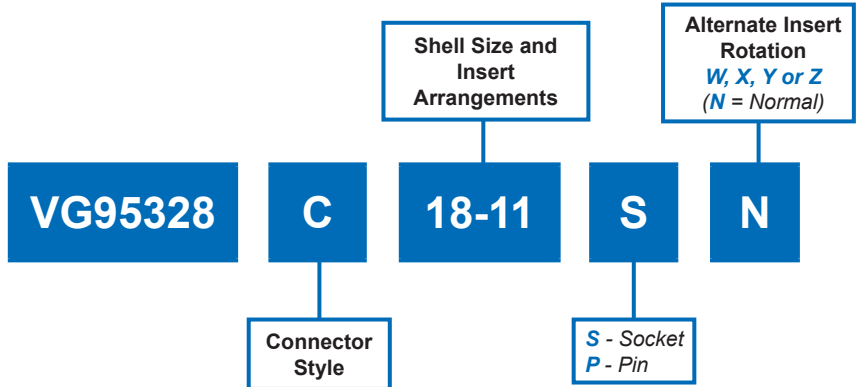

TABLE I: DIMENSIONS

Shell size	B Max.	D1 +0.8 -0.6	D2* Min.	E ± 0.15	L1 Max.	L2 +0.8 -0	L3 Max.	Maximum Weight in Grams
8	21.03	11.2	2.9	15.08	33.5	10.94	2.0	6
10	24.23	14.3	2.9	18.26	33.5	10.94	2.0	7
12	26.59	17.5	2.9	20.62	33.5	10.94	2.0	10
14	28.98	20.7	2.9	23.01	33.5	10.94	2.0	12
16	31.34	23.9	2.9	24.61	33.5	10.94	2.0	14
18	33.73	27.0	2.9	26.97	33.5	10.94	2.0	17
20	36.90	30.2	2.9	29.36	34.7	14.12	2.8	21
22	40.08	33.4	2.9	31.75	36.0	14.12	2.8	25
24	43.25	36.6	3.6	34.92	36.0	14.96	2.8	27

* Through Mounting Holes

VG95328 C Bayonet-Lock Rear Box Mount Square Flange Receptacle



VG95328
Connectors

Contact Arrangements			
Arrangement	Cl. Isol. Rating	Dim. contact size	
		20	16
8 - 3A	I	3	
10 - 6	I	6	
12 - 3	II		3
12 - 10	I	10	
14 - 5	II		5
14 - 12	I	8	4
14 - 15	I	14	1
14 - 19	I	19	
16 - 8	II		8
16 - 23	I	22	1
16 - 26	I	26	
18 - 11	II		11
18 - 32	I	32	
20 - 16	II		16
20 - 41	I	41	
22 - 21	II		21
22 - 55	I	55	
24 - 61	I	61	

Alternate Insert Orientations				
Arrangement	Degrees			
	W	X	Y	Z
8 - 3A	60	(120)		
10 - 6	90			
12 - 3			180	
12 - 10	60	155	270	295
14 - 5	40	92	184	273
14 - 12	43	90		
14 - 15	17	110	155	234
14 - 19	30	165	315	
16 - 8	54	152	180	331
16 - 23	158	270		
16 - 26	60		275	338
18 - 11	62	119	241	340
18 - 32	85	138	222	265
20 - 16	238	318	333	347
20 - 41	45	126	225	
22 - 21	16	135	175	349
22 - 55	30	142	226	314
24 - 61	90	180	270	324

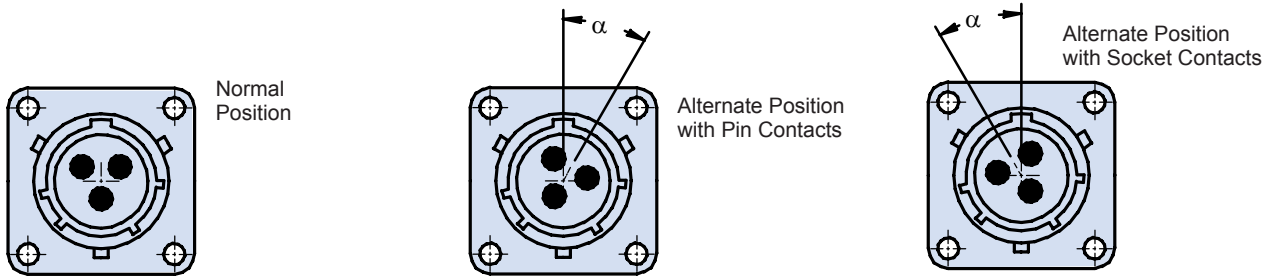

MATERIALS	
SHELLS	INSERTS (Temperature Range)
Aluminum Alloy IAW QQ-A-591 Shells	High Insulation Synthetic Rubber (Chloroprene): -55°C/+125°C
Stainless Steel Coupling Pins	CRIMP CONTACTS
Stainless Steel Spring	Copper Alloy with Gold Plating Over Nickel

STANDARD FINISH (For QQ-A-591 Aluminum Shells)	
Requirements	Cadmium with Olive Drab Passivation IAW QQ-P-416
Thermal Shock	-55°C + 125°C
Salt Spray After Thermal Shock	500 hour
Electrical Conductivity	Very Good
Abrasion Resistance	Very Good

See Page 13 for Panel Thickness and Cutout Dimensions

VG95328 D Bayonet-Lock Rear Panel Mount Jam Nut Receptacle with Backshell

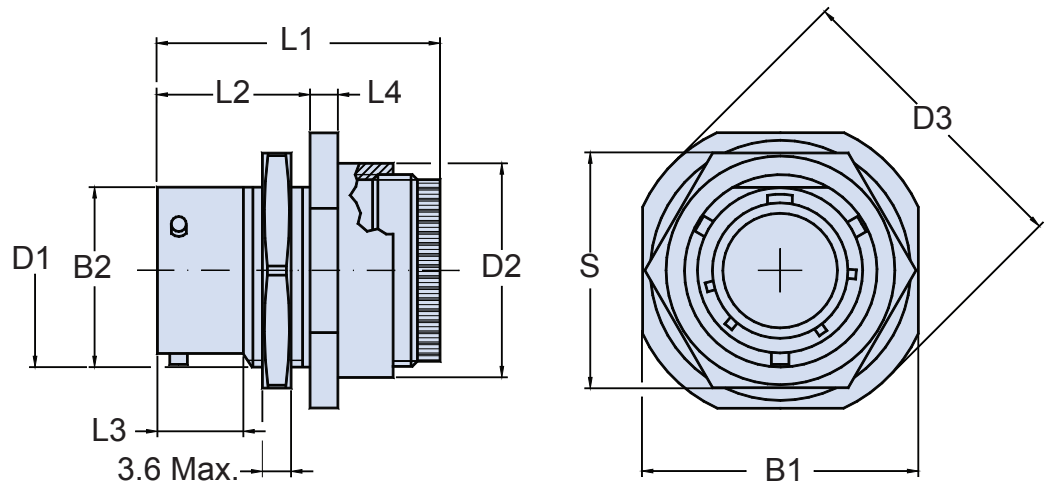
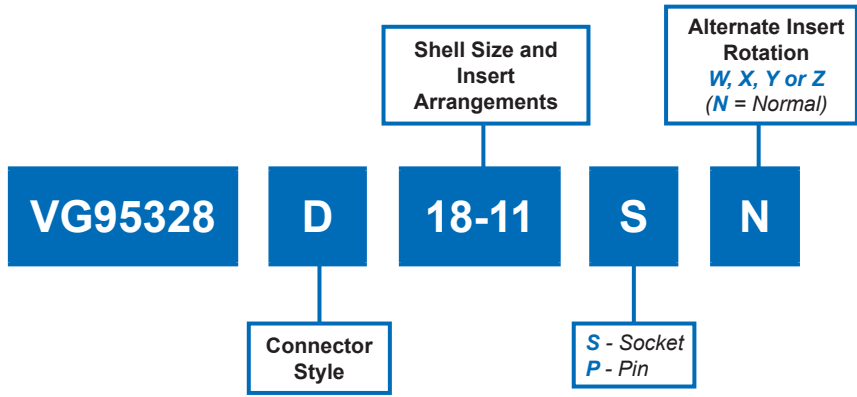

TABLE I: DIMENSIONS

Shell size	B1 Max.	B2 +0 -0.25	D1	D2 Min.	D3 +0 -0.8	L1 Max.	L2 +0.8 -0	L3 Min.	L4 ±0.5	S ±0.43	Maximum Weight in Grams
8	24.3	13.46	0.5625 - 24 UNEF	19.0	27.3	39.3	17.5	9.75	3.0	19.05	20
10	27.4	16.64	0.6875 - 24 UNEF	22.2	30.5	39.3	17.5	9.75	3.0	22.23	21
12	32.2	20.78	0.8750 - 20 UNEF	25.4	35.3	39.3	17.5	9.75	3.0	26.97	30
14	35.4	23.93	1.0000 - 20 UNEF	28.5	38.5	39.3	17.5	9.75	3.0	30.18	39
16	38.6	27.08	1.1250 - 18 UNEF	31.7	41.6	39.3	17.5	9.75	3.0	33.32	49
18	41.7	30.25	1.2500 - 18 UNEF	34.9	44.8	39.3	17.5	9.75	3.0	36.53	57
20	46.5	33.43	1.3750 - 18 UNEF	38.8	49.6	43.4	22.3	11.32	3.8	39.67	78
22	49.7	36.60	1.5000 - 18 UNEF	42.0	52.7	43.4	22.3	11.32	3.8	42.88	97
24	52.8	39.78	1.6250 - 18 UNEF	45.2	55.9	43.4	23.1	12.16	3.8	46.02	115

Single Hole Mounting

VG95328 D Bayonet-Lock Rear Panel Mount Jam Nut Receptacle with Backshell



VG95328
Connectors

Contact Arrangements			
Arrangement	Cl. Isol. Rating	Dim. contact size	
		20	16
8 - 3A	I	3	
10 - 6	I	6	
12 - 3	II		3
12 - 10	I	10	
14 - 5	II		5
14 - 12	I	8	4
14 - 15	I	14	1
14 - 19	I	19	
16 - 8	II		8
16 - 23	I	22	1
16 - 26	I	26	
18 - 11	II		11
18 - 32	I	32	
20 - 16	II		16
20 - 41	I	41	
22 - 21	II		21
22 - 55	I	55	
24 - 61	I	61	

Alternate Insert Orientations				
Arrangement	Degrees			
	W	X	Y	Z
8 - 3A	60	(120)		
10 - 6	90			
12 - 3			180	
12 - 10	60	155	270	295
14 - 5	40	92	184	273
14 - 12	43	90		
14 - 15	17	110	155	234
14 - 19	30	165	315	
16 - 8	54	152	180	331
16 - 23	158	270		
16 - 26	60		275	338
18 - 11	62	119	241	340
18 - 32	85	138	222	265
20 - 16	238	318	333	347
20 - 41	45	126	225	
22 - 21	16	135	175	349
22 - 55	30	142	226	314
24 - 61	90	180	270	324

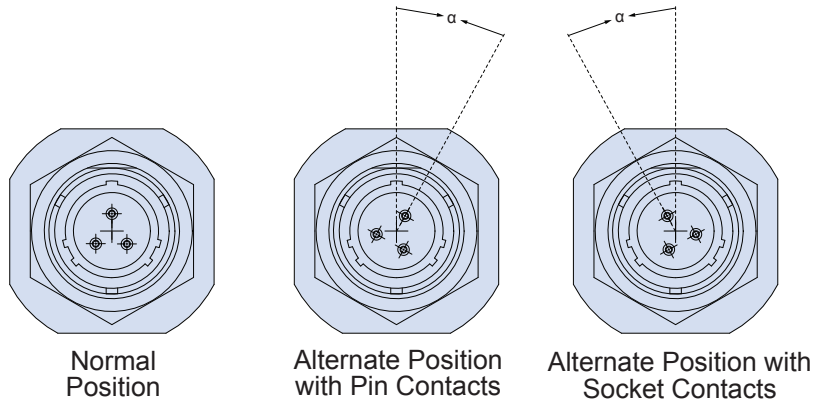

MATERIALS	
SHELLS	INSERTS (Temperature Range)
Aluminum Alloy IAW QQ-A-591 Shells	High Insulation Synthetic Rubber (Chloroprene): -55°C/+125°C
Stainless Steel Coupling Pins	CRIMP CONTACTS
Stainless Steel Spring	Copper Alloy with Gold Plating Over Nickel

STANDARD FINISH (For QQ-A-591 Aluminum Shells)	
Requirements	Cadmium with Olive Drab Passivation IAW QQ-P-416
Thermal Shock	-55°C + 125°C
Salt Spray After Thermal Shock	500 hour
Electrical Conductivity	Very Good
Abrasion Resistance	Very Good

See Page 13 for Panel Thickness and Cutout Dimensions

VG95328 E Bayonet-Lock Rear Panel Mount Jam Nut Receptacle with Cable Clamp and Bushing

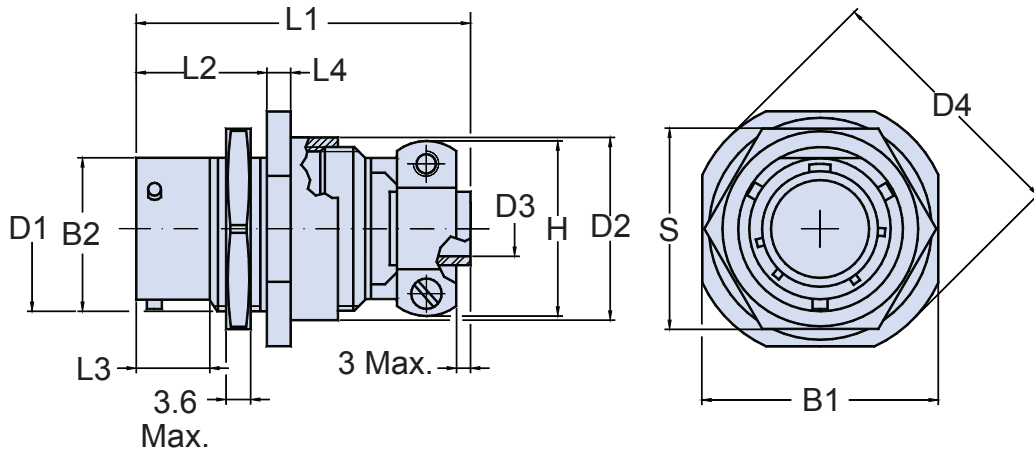
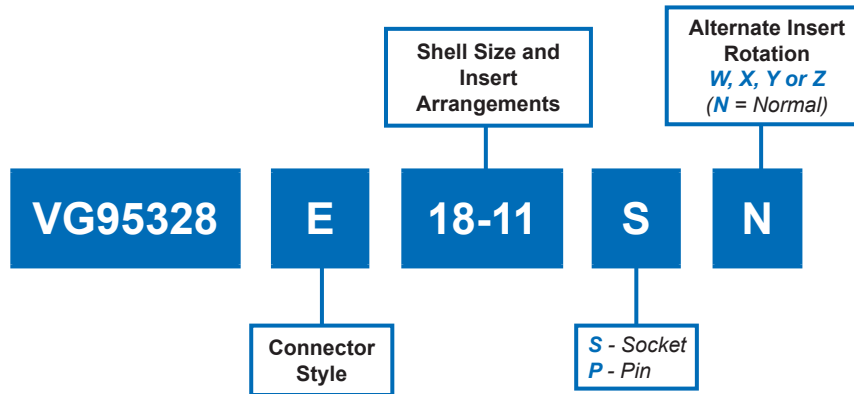

TABLE I: DIMENSIONS

Shell size	B1 Max.	B2 +0 -0.25	D1	D2 Min.	D3 + 0.3 - 0.7	D4 + 0 - 0.8	L1 Max.	L2 + 0.8 - 0	L3 Min.	L4 ± 0.15	S ± 0.43	Maximum Weight in Grams
8	24.3	13.46	0.5625 - 24 UNEF	19.0	3.2	27.3	61.5	17.5	9.75	3.0	19.05	25
10	27.4	16.64	0.6875 - 24 UNEF	22.2	4.8	30.5	61.5	17.5	9.75	3.0	22.23	25
12	32.2	20.78	0.8750 - 20 UNEF	25.4	7.9	35.3	61.5	17.5	9.75	3.0	26.97	37
14	35.4	23.93	1.0000 - 20 UNEF	28.5	9.5	38.5	61.5	17.5	9.75	3.0	30.18	50
16	38.6	27.08	1.1250 - 18 UNEF	31.7	12.7	41.6	64.4	17.5	9.75	3.0	33.32	63
18	41.7	30.25	1.2500 - 18 UNEF	34.9	15.9	44.8	64.4	17.5	9.75	3.0	36.53	74
20	46.5	33.43	1.3750 - 18 UNEF	38.8	15.9	49.6	71.1	22.3	11.32	3.8	39.67	97
22	49.7	36.60	1.5000 - 18 UNEF	42.0	19.1	52.7	71.1	22.3	11.32	3.8	42.88	117
24	52.8	39.78	1.6250 - 18 UNEF	45.2	20.3	55.9	73.6	23.1	12.16	3.8	46.02	137

Single Hole Mounting

VG95328 E Bayonet-Lock Rear Panel Mount Jam Nut Receptacle with Cable Clamp and Bushing



VG95328
Connectors

Contact Arrangements			
Arrangement	Cl. Isol. Rating	Dim. contact size	
		20	16
8 - 3A	I	3	
10 - 6	I	6	
12 - 3	II		3
12 - 10	I	10	
14 - 5	II		5
14 - 12	I	8	4
14 - 15	I	14	1
14 - 19	I	19	
16 - 8	II		8
16 - 23	I	22	1
16 - 26	I	26	
18 - 11	II		11
18 - 32	I	32	
20 - 16	II		16
20 - 41	I	41	
22 - 21	II		21
22 - 55	I	55	
24 - 61	I	61	

Alternate Insert Orientations				
Arrangement	Degrees			
	W	X	Y	Z
8 - 3A	60	(120)		
10 - 6	90			
12 - 3			180	
12 - 10	60	155	270	295
14 - 5	40	92	184	273
14 - 12	43	90		
14 - 15	17	110	155	234
14 - 19	30	165	315	
16 - 8	54	152	180	331
16 - 23	158	270		
16 - 26	60		275	338
18 - 11	62	119	241	340
18 - 32	85	138	222	265
20 - 16	238	318	333	347
20 - 41	45	126	225	
22 - 21	16	135	175	349
22 - 55	30	142	226	314
24 - 61	90	180	270	324

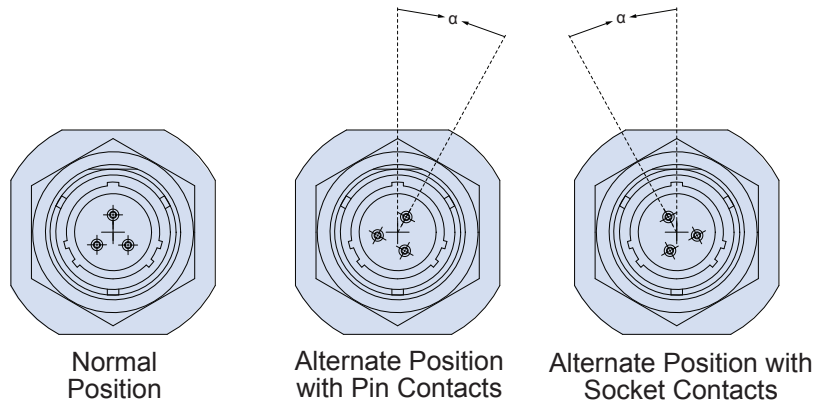

MATERIALS	
SHELLS	INSERTS (Temperature Range)
Aluminum Alloy IAW QQ-A-591 Shells	High Insulation Synthetic Rubber (Chloroprene): -55°C/+125°C
Stainless Steel Coupling Pins	CRIMP CONTACTS
Stainless Steel Spring	Copper Alloy with Gold Plating Over Nickel

STANDARD FINISH (For QQ-A-591 Aluminum Shells)	
Requirements	Cadmium with Olive Drab Passivation IAW QQ-P-416
Thermal Shock	-55°C + 125°C
Salt Spray After Thermal Shock	500 hour
Electrical Conductivity	Very Good
Abrasion Resistance	Very Good

See Page 13 for Panel Thickness and Cutout Dimensions

VG95328 F
Bayonet-Lock
Rear Panel Mount Hermetic Jam Nut
Receptacle with Pin Solder Contacts

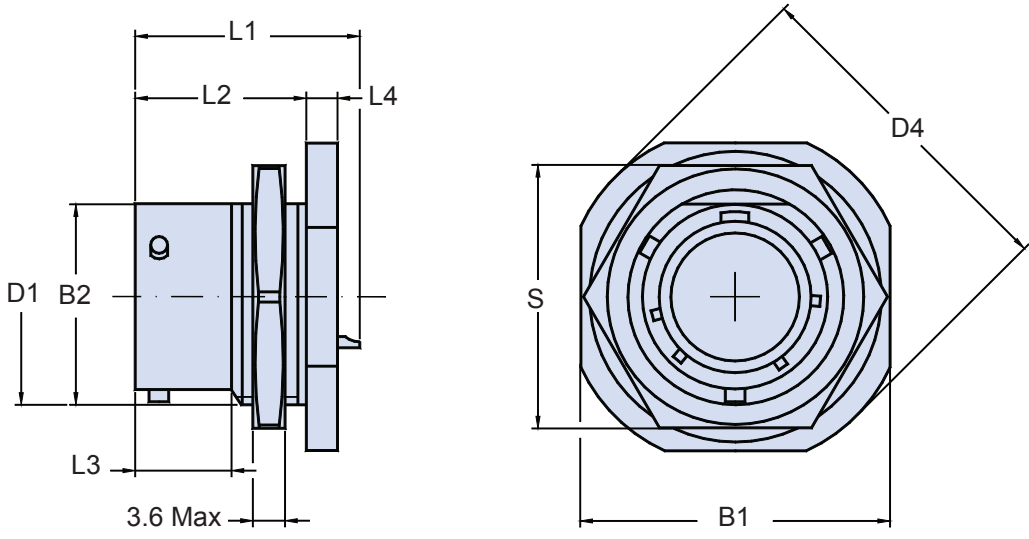
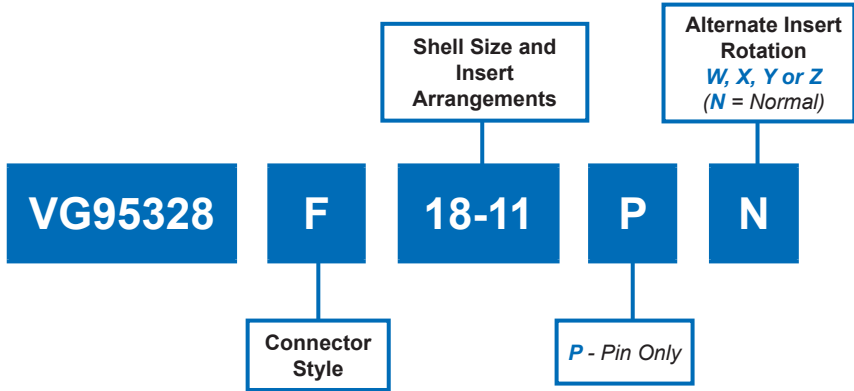

TABLE I: DIMENSIONS

Shell Size	B1 Max	B2 +0 -0.25	D1	D4 +0 -0.8	L1 Max	L2 +0.8 -0	L3 Min	L4 ± 0.15	S ± 0.43	Maximum Weight in Grams
8	24.3	13.46	0.5626 - 24 UNEF	27.3	26.0	17.5	9.75	3.0	19.05	20
10	27.4	16.64	0.6875 - 24 UNEF	30.5	26.0	17.5	9.75	3.0	22.23	26
12	32.2	20.78	0.8750 - 20 UNEF	35.3	26.0	17.5	9.75	3.0	26.97	40
14	35.4	23.93	1.0000 - 20 UNEF	38.5	26.0	17.5	9.75	3.0	30.18	46
16	38.6	27.08	1.1250 - 18 UNEF	41.6	26.0	17.5	9.75	3.0	33.32	56
18	41.7	30.25	1.2500 - 18 UNEF	44.8	26.0	17.5	9.75	3.0	36.53	68
20	46.5	33.43	1.3750 - 18 UNEF	49.6	32.0	22.3	22.3	3.8	39.67	90
22	49.7	36.60	1.5000 - 18 UNEF	52.7	32.0	22.3	22.3	3.8	42.88	105
24	52.8	39.78	1.6250 - 18 UNEF	55.9	32.0	23.1	23.1	3.8	46.02	115

Single Hole Mounting

VG95328 F Bayonet-Lock Rear Panel Mount Hermetic Jam Nut Receptacle with Pin Solder Contacts



VG95328
Connectors

Contact Arrangements			
Arrangement	Cl. Isol. Rating	Dim. contact size	
		20	16
8 - 3A	I	3	
10 - 6	I	6	
12 - 3	II		3
12 - 10	I	10	
14 - 5	II		5
14 - 12	I	8	4
14 - 15	I	14	1
14 - 19	I	19	
16 - 8	II		8
16 - 23	I	22	1
16 - 26	I	26	
18 - 11	II		11
18 - 32	I	32	
20 - 16	II		16
20 - 41	I	41	
22 - 21	II		21
22 - 55	I	55	
24 - 61	I	61	

Alternate Insert Orientations				
Arrangement	Degrees			
	W	X	Y	Z
8 - 3A	60	(120)		
10 - 6	90			
12 - 3			180	
12 - 10	60	155	270	295
14 - 5	40	92	184	273
14 - 12	43	90		
14 - 15	17	110	155	234
14 - 19	30	165	315	
16 - 8	54	152	180	331
16 - 23	158	270		
16 - 26	60		275	338
18 - 11	62	119	241	340
18 - 32	85	138	222	265
20 - 16	238	318	333	347
20 - 41	45	126	225	
22 - 21	16	135	175	349
22 - 55	30	142	226	314
24 - 61	90	180	270	324

Class F, G and H hermetic versions not qualified to VG95328. Please consult factory for Glenair commercial equivalent MIL-DTL-26482 and VG95328 type hermetic connectors.

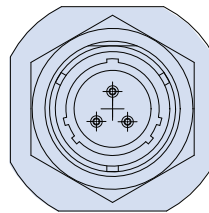

Normal Position

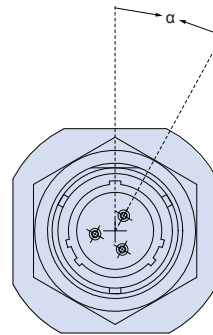

Alternate Position with Pin Contacts

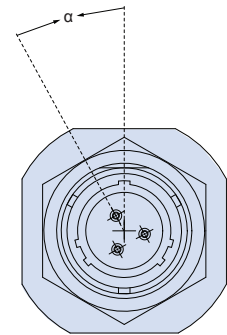

Alternate Position with Socket Contacts

MATERIALS	
SHELLS	INSERTS
Aluminum Alloy IAW QQ-A-591 Shells	Glass
Stainless Steel Coupling Pins	SOLDER CONTACTS
Stainless Steel Spring	Copper Alloy with Gold Plating Over Nickel

STANDARD FINISH (For QQ-A-591 Aluminum Shells)	
Requirements	Cadmium with Olive Drab Passivation IAW QQ-P-416
Thermal Shock	-55°C + 125°C
Salt Spray After Thermal Shock	500 hour
Electrical Conductivity	Very Good
Abrasion Resistance	Very Good

See Page 13 for Panel Thickness and Cutout Dimensions

VG95328 G Bayonet-Lock Solder Mount Hermetic Receptacle with Pin Solder Contacts

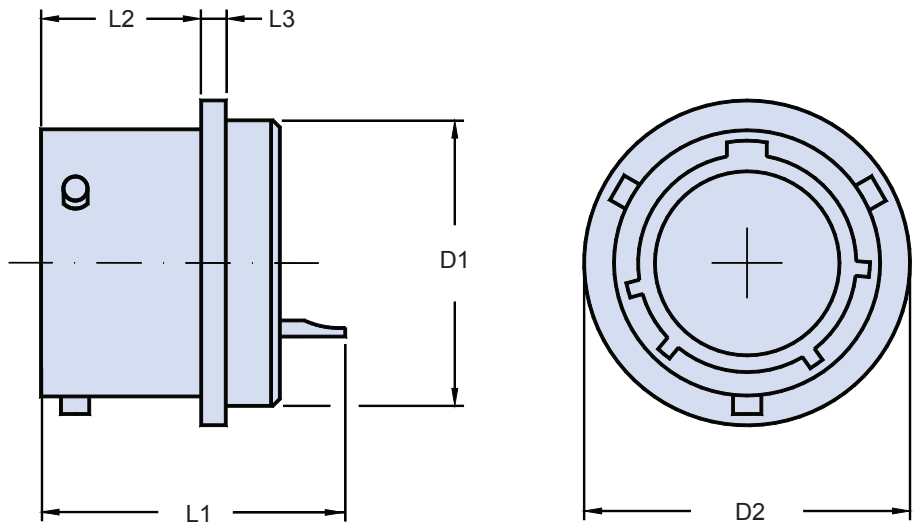
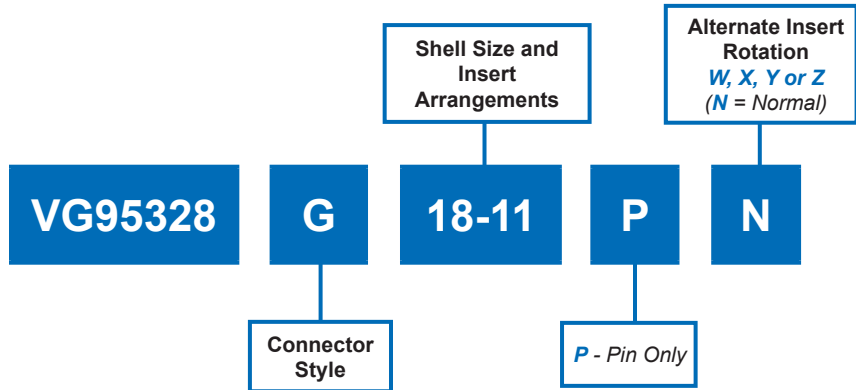

TABLE I: DIMENSIONS						
Shell Size	D1 +0.02 -0.13	D2 ±0.4	L1 Max	L2 +0.8 -0	L3 +0.4 -0.13	Maximum Weight in Grams
8	14.27	15.9	21.0	10.5	0.8	8
10	17.07	19.1	21.0	10.5	0.8	13
12	19.84	21.4	21.0	10.5	0.8	20
14	23.01	24.6	21.0	10.5	0.8	23
16	26.19	27.8	21.0	10.5	0.8	26
18	29.36	30.9	21.0	10.5	0.8	32
20	31.75	33.3	22.6	12.1	0.8	44
22	34.92	36.5	23.4	12.1	0.8	56
24	38.10	39.7	23.4	12.9	0.8	60

Single Hole Mounting

VG95328 G Bayonet-Lock Solder Mount Hermetic Receptacle with Pin Solder Contacts



VG95328
Connectors

Contact Arrangements			
Arrangement	Cl. Isol. Rating	Dim. contact size	
		20	16
8 - 3A	I	3	
10 - 6	I	6	
12 - 3	II		3
12 - 10	I	10	
14 - 5	II		5
14 - 12	I	8	4
14 - 15	I	14	1
14 - 19	I	19	
16 - 8	II		8
16 - 23	I	22	1
16 - 26	I	26	
18 - 11	II		11
18 - 32	I	32	
20 - 16	II		16
20 - 41	I	41	
22 - 21	II		21
22 - 55	I	55	
24 - 61	I	61	

Alternate Insert Orientations				
Arrangement	Degrees			
	W	X	Y	Z
8 - 3A	60	(120)		
10 - 6	90			
12 - 3			180	
12 - 10	60	155	270	295
14 - 5	40	92	184	273
14 - 12	43	90		
14 - 15	17	110	155	234
14 - 19	30	165	315	
16 - 8	54	152	180	331
16 - 23	158	270		
16 - 26	60		275	338
18 - 11	62	119	241	340
18 - 32	85	138	222	265
20 - 16	238	318	333	347
20 - 41	45	126	225	
22 - 21	16	135	175	349
22 - 55	30	142	226	314
24 - 61	90	180	270	324

Class F, G and H hermetic versions not qualified to VG95328. Please consult factory for Glenair commercial equivalent MIL-DTL-26482 and VG95328 type hermetic connectors.

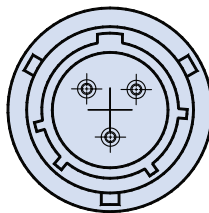

Normal Position

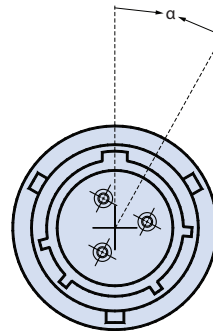

Alternate Position with Pin Contacts

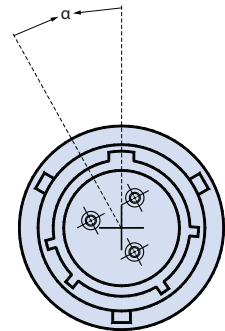

Alternate Position with Socket Contacts

MATERIALS	
SHELLS	INSERTS
Aluminum Alloy IAW QQ-A-591 Shells	Glass
Stainless Steel Coupling Pins	SOLDER CONTACTS
Stainless Steel Spring	Copper Alloy with Gold Plating Over Nickel

STANDARD FINISH (For QQ-A-591 Aluminum Shells)	
Requirements	Cadmium with Olive Drab Passivation IAW QQ-P-416
Thermal Shock	-55°C + 125°C
Salt Spray After Thermal Shock	500 hour
Electrical Conductivity	Very Good
Abrasion Resistance	Very Good

Consult Factory for Panel Thickness and Cutout Dimensions

VG95328 H
Bayonet-Lock
Front Panel Mount Square Flange Hermetic Receptacle
with Solder Contacts

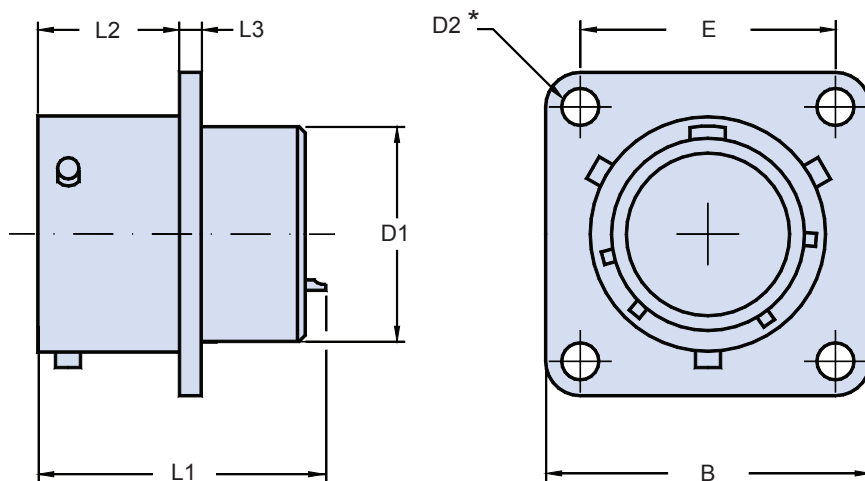
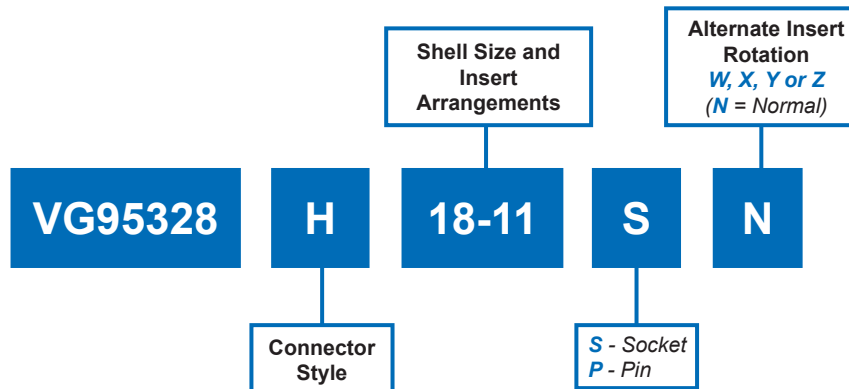

TABLE I: DIMENSIONS								
Shell Size	B Max	D1 +0.8 -0.6	D2 * Min	E ±0.15	L1 Max	L2 +0.8 -0	L3 Max	Maximum Weight in Grams
8	21.03	11.2	2.9	15.08	24.9	10.94	2.0	7
10	24.23	14.3	2.9	18.26	24.9	10.94	2.0	10
12	26.59	17.5	2.9	20.62	24.9	10.94	2.0	20
14	28.98	20.7	2.9	23.01	24.9	10.94	2.0	20
16	31.34	23.9	2.9	24.61	24.9	10.94	2.0	28
18	33.73	27.0	2.9	26.97	24.9	10.94	2.0	34
20	36.90	30.2	2.9	29.36	30.4	14.12	2.8	43
22	40.08	33.4	2.9	31.75	30.4	14.12	2.8	55
24	43.25	36.6	3.6	34.92	30.4	14.96	2.8	70

* Through Mounting Holes

VG95328 H Bayonet-Lock Front Panel Mount Square Flange Hermetic Receptacle with Solder Contacts



VG95328
Connectors

Contact Arrangements			
Arrangement	Cl. Isol. Rating	Dim. contact size	
		20	16
8 - 3A	I	3	
10 - 6	I	6	
12 - 3	II		3
12 - 10	I	10	
14 - 5	II		5
14 - 12	I	8	4
14 - 15	I	14	1
14 - 19	I	19	
16 - 8	II		8
16 - 23	I	22	1
16 - 26	I	26	
18 - 11	II		11
18 - 32	I	32	
20 - 16	II		16
20 - 41	I	41	
22 - 21	II		21
22 - 55	I	55	
24 - 61	I	61	

Alternate Insert Orientations				
Arrangement	Degrees			
	W	X	Y	Z
8 - 3A	60	(120)		
10 - 6	90			
12 - 3			180	
12 - 10	60	155	270	295
14 - 5	40	92	184	273
14 - 12	43	90		
14 - 15	17	110	155	234
14 - 19	30	165	315	
16 - 8	54	152	180	331
16 - 23	158	270		
16 - 26	60		275	338
18 - 11	62	119	241	340
18 - 32	85	138	222	265
20 - 16	238	318	333	347
20 - 41	45	126	225	
22 - 21	16	135	175	349
22 - 55	30	142	226	314
24 - 61	90	180	270	324

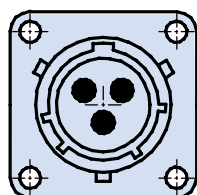

Normal Position

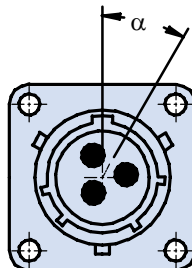

Alternate Position with Pin Contacts

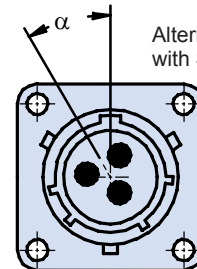

Alternate Position with Socket Contacts

**Class F, G and H hermetic versions not qualified to VG95328.
Please consult factory for Glenair commercial equivalent
MIL-DTL-26482 and VG95328 type hermetic connectors.**

MATERIALS	
SHELLS	INSERTS
Aluminum Alloy IAW QQ-A-591 Shells	Glass
Stainless Steel Coupling Pins	SOLDER CONTACTS
Stainless Steel Spring	Copper Alloy with Gold Plating Over Nickel

STANDARD FINISH (For QQ-A-591 Aluminum Shells)	
Requirements	Cadmium with Olive Drab Passivation IAW QQ-P-416
Thermal Shock	-55°C + 125°C
Salt Spray After Thermal Shock	500 hour
Electical Conductivity	Very Good
Abrasion Resistance	Very Good

See Page 13 for Panel Thickness and Cutout Dimensions

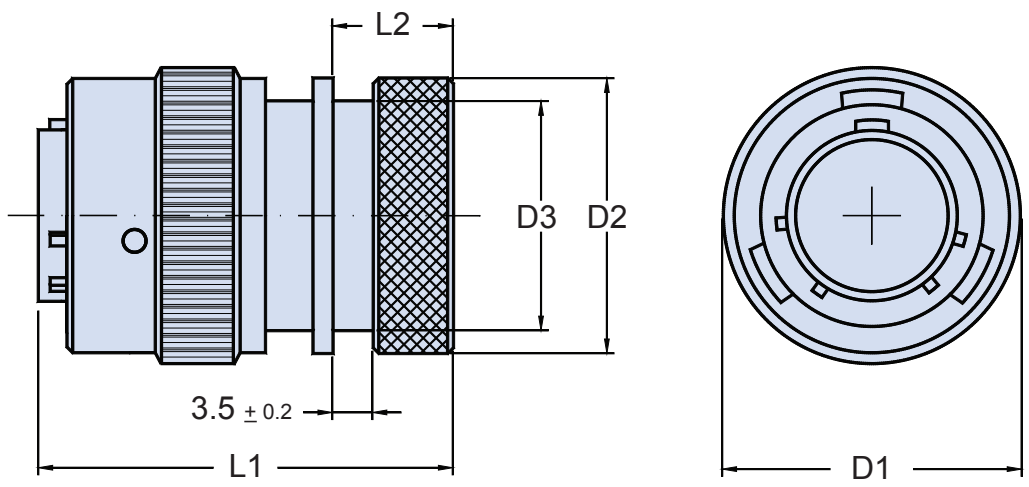
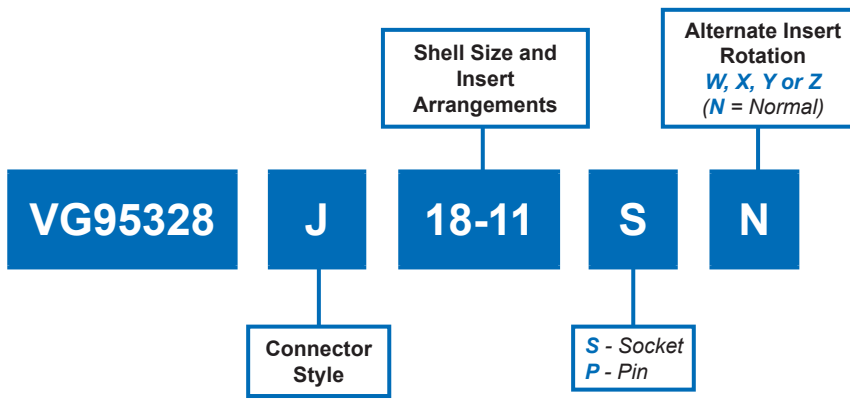

TABLE I: DIMENSIONS						
Shell size	D1 Max.	D2 +0 -0.5	D3 +0 -0.5	L1 Max.	L2 ± 0.5	Maximum Weight in Grams
8	19.8	15.6	13.3	39	12.2	14
10	23.5	18.4	16.1	39	12.2	16
12	26.5	23.7	21.4	39	12.2	23
14	30.0	24.5	22.2	39	12.2	30
16	33.1	29.8	26.2	39	14.5	43
18	35.3	32.0	28.5	39	14.5	46
20	38.8	36.1	32.5	44	15.8	63
22	42.0	38.5	34.8	44	15.8	78
24	45.1	41.6	37.9	44	14.9	84

VG95328 J Bayonet-Lock Straight Plug Connector with Shrinkboot Backshell



VG95328
Connectors

Contact Arrangements			
Arrangement	Cl. Isol. Rating	Dim. contact size	
		20	16
8 - 3A	I	3	
10 - 6	I	6	
12 - 3	II		3
12 - 10	I	10	
14 - 5	II		5
14 - 12	I	8	4
14 - 15	I	14	1
14 - 19	I	19	
16 - 8	II		8
16 - 23	I	22	1
16 - 26	I	26	
18 - 11	II		11
18 - 32	I	32	
20 - 16	II		16
20 - 41	I	41	
22 - 21	II		21
22 - 55	I	55	
24 - 61	I	61	

Alternate Insert Orientations				
Arrangement	Degrees			
	W	X	Y	Z
8 - 3A	60	(120)		
10 - 6	90			
12 - 3			180	
12 - 10	60	155	270	295
14 - 5	40	92	184	273
14 - 12	43	90		
14 - 15	17	110	155	234
14 - 19	30	165	315	
16 - 8	54	152	180	331
16 - 23	158	270		
16 - 26	60		275	338
18 - 11	62	119	241	340
18 - 32	85	138	222	265
20 - 16	238	318	333	347
20 - 41	45	126	225	
22 - 21	16	135	175	349
22 - 55	30	142	226	314
24 - 61	90	180	270	324

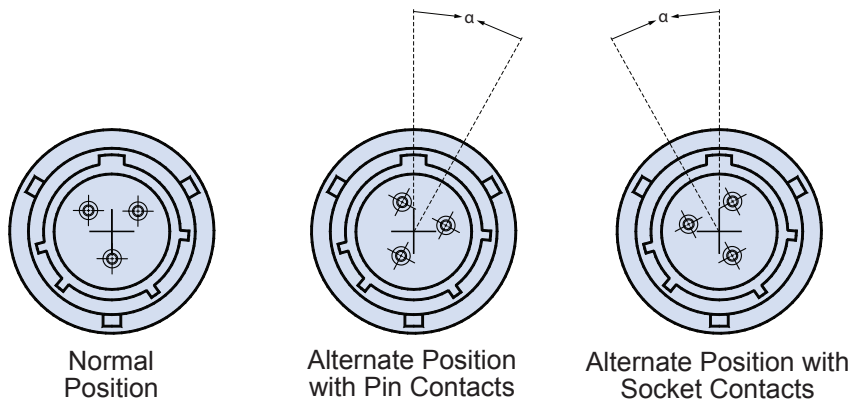

MATERIALS	
SHELLS	INSERTS (Temperature Range)
Aluminum Alloy IAW QQ-A-591 Shells	High Insulation Synthetic Rubber (Chloroprene): -55°C/+125°C
Stainless Steel Coupling Pins	CRIMP CONTACTS
Stainless Steel Spring	Copper Alloy with Gold Plating Over Nickel

STANDARD FINISH (For QQ-A-591 Aluminum Shells)	
Requirements	Cadmium with Olive Drab Passivation IAW QQ-P-416
Thermal Shock	-55°C + 125°C
Salt Spray After Thermal Shock	500 hour
Electrical Conductivity	Very Good
Abrasion Resistance	Very Good

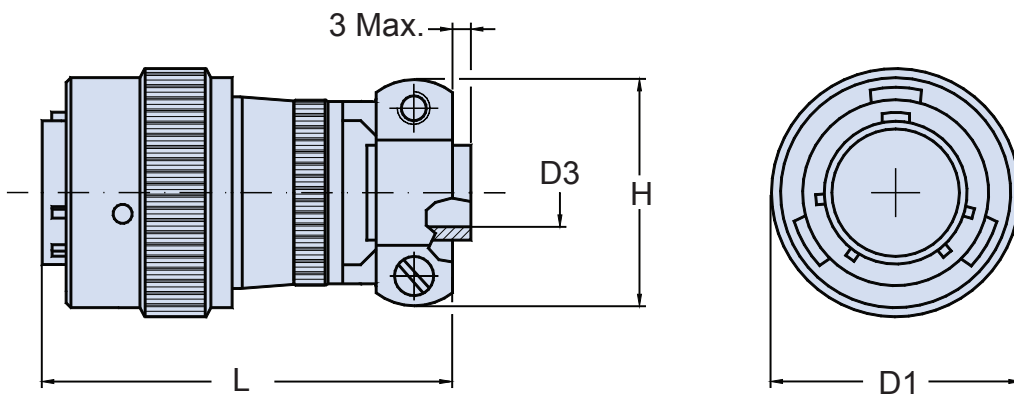
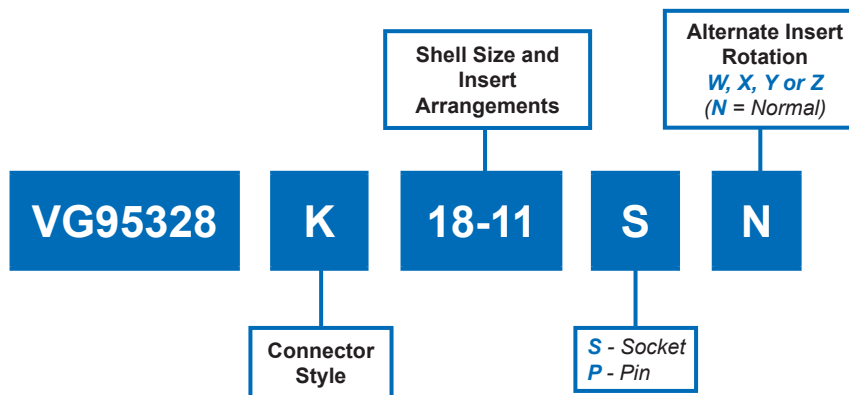

TABLE I: DIMENSIONS

Shell size	D1 Max.	D3 + 0.3 - 0.7	H Max.	L Max.	Maximum Weight in Grams
8	19.8	3.2	21.1	61.3	22
10	23.5	4.8	22.7	61.3	24
12	26.5	7.9	25.9	61.3	30
14	30.0	9.5	29.0	61.3	40
16	33.1	12.7	30.6	64.3	47
18	35.3	15.9	37.4	64.3	62
20	38.8	15.9	37.4	70.0	79
22	42.0	19.1	42.1	70.0	97
24	45.1	20.3	44.5	71.9	104

VG95328 K Bayonet-Lock Straight Plug Connector with Cable Clamp and Bushing



VG95328
Connectors

Contact Arrangements			
Arrangement	Cl. Isol. Rating	Dim. contact size	
		20	16
8 - 3A	I	3	
10 - 6	I	6	
12 - 3	II		3
12 - 10	I	10	
14 - 5	II		5
14 - 12	I	8	4
14 - 15	I	14	1
14 - 19	I	19	
16 - 8	II		8
16 - 23	I	22	1
16 - 26	I	26	
18 - 11	II		11
18 - 32	I	32	
20 - 16	II		16
20 - 41	I	41	
22 - 21	II		21
22 - 55	I	55	
24 - 61	I	61	

Alternate Insert Orientations				
Arrangement	Degrees			
	W	X	Y	Z
8 - 3A	60	(120)		
10 - 6	90			
12 - 3			180	
12 - 10	60	155	270	295
14 - 5	40	92	184	273
14 - 12	43	90		
14 - 15	17	110	155	234
14 - 19	30	165	315	
16 - 8	54	152	180	331
16 - 23	158	270		
16 - 26	60		275	338
18 - 11	62	119	241	340
18 - 32	85	138	222	265
20 - 16	238	318	333	347
20 - 41	45	126	225	
22 - 21	16	135	175	349
22 - 55	30	142	226	314
24 - 61	90	180	270	324

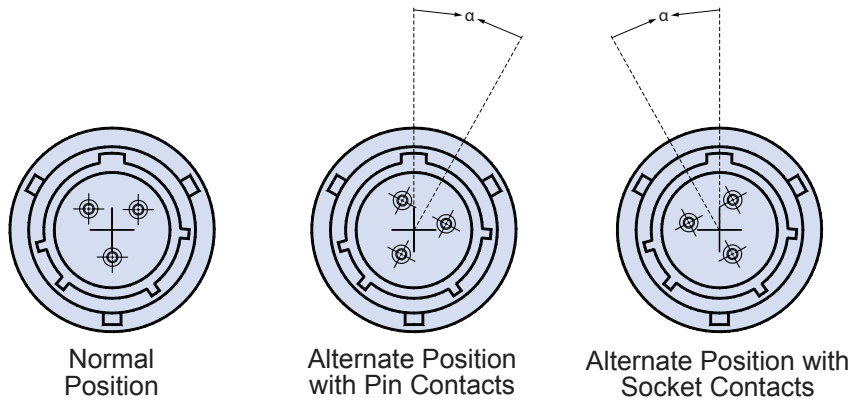

MATERIALS	
SHELLS	INSERTS (Temperature Range)
Aluminum Alloy IAW QQ-A-591 Shells	High Insulation Synthetic Rubber (Chloroprene): -55°C/+125°C
Stainless Steel Coupling Pins	CRIMP CONTACTS
Stainless Steel Spring	Copper Alloy with Gold Plating Over Nickel

STANDARD FINISH (For QQ-A-591 Aluminum Shells)	
Requirements	Cadmium with Olive Drab Passivation IAW QQ-P-416
Thermal Shock	-55°C + 125°C
Salt Spray After Thermal Shock	500 hour
Electrical Conductivity	Very Good
Abrasion Resistance	Very Good

VG95328 L
Bayonet-Lock
Straight Plug Connector with Thumb-Lock Lever
and Heat-Shrink Boot Backshell

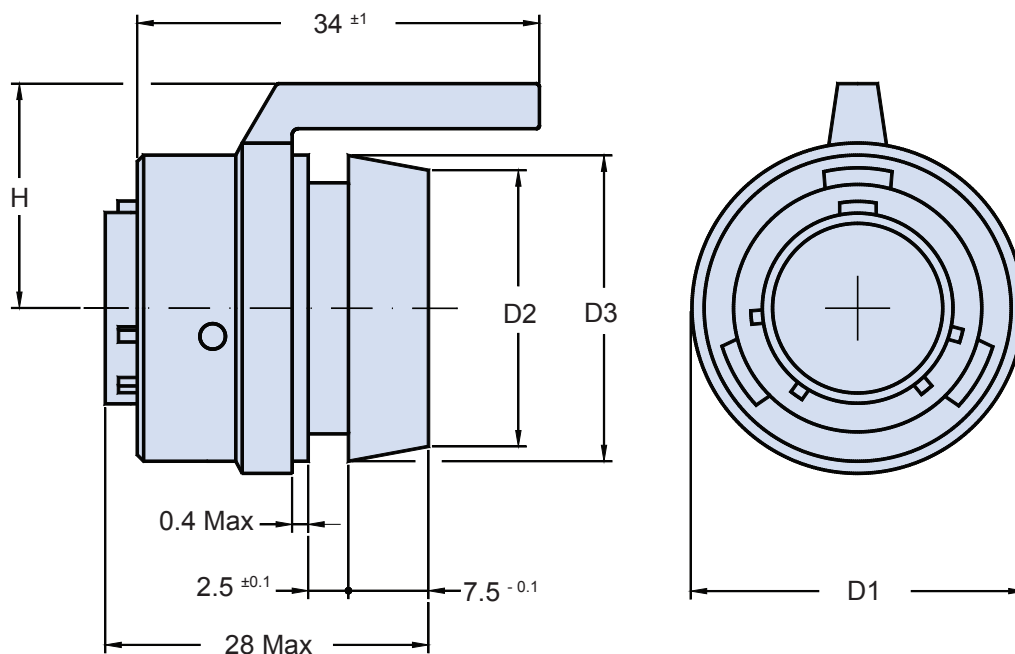
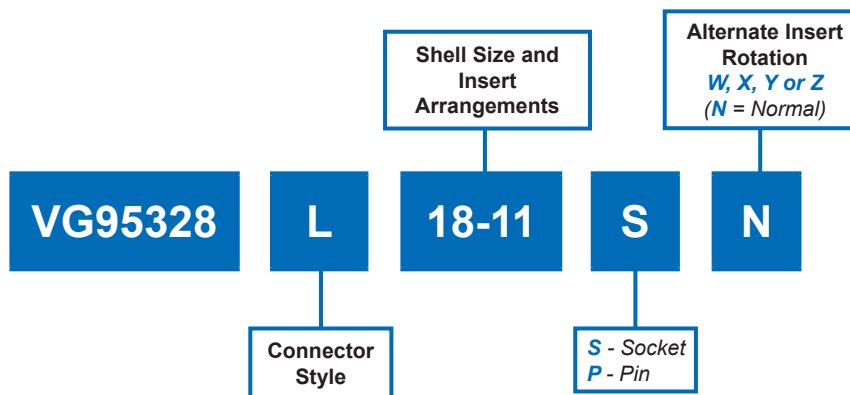

TABLE I: DIMENSIONS					
Shell Size	D1 ± 1	D2 ± 0.5	D3 ± 0.5	H ± 1	Maximum Weight in Grams
14	28	19.0	21	20	16
16	31	22.2	24	21	16

VG95328 L Bayonet-Lock Straight Plug Connector with Thumb-Lock Lever and Heat-Shrink Boot Backshell



VG95328
Connectors

Contact Arrangements			
Arrangement	Cl. Isol. Rating	Dim. contact size	
		20	16
8 - 3A	I	3	
10 - 6	I	6	
12 - 3	II		3
12 - 10	I	10	
14 - 5	II		5
14 - 12	I	8	4
14 - 15	I	14	1
14 - 19	I	19	
16 - 8	II		8
16 - 23	I	22	1
16 - 26	I	26	
18 - 11	II		11
18 - 32	I	32	
20 - 16	II		16
20 - 41	I	41	
22 - 21	II		21
22 - 55	I	55	
24 - 61	I	61	

Alternate Insert Orientations				
Arrangement	Degrees			
	W	X	Y	Z
8 - 3A	60	(120)		
10 - 6	90			
12 - 3			180	
12 - 10	60	155	270	295
14 - 5	40	92	184	273
14 - 12	43	90		
14 - 15	17	110	155	234
14 - 19	30	165	315	
16 - 8	54	152	180	331
16 - 23	158	270		
16 - 26	60		275	338
18 - 11	62	119	241	340
18 - 32	85	138	222	265
20 - 16	238	318	333	347
20 - 41	45	126	225	
22 - 21	16	135	175	349
22 - 55	30	142	226	314
24 - 61	90	180	270	324

Class L, U, and W Thumb-Lock versions not qualified to VG95328. Please consult factory for Glenair commercial equivalent VG95328 type Thumb-Lock connectors

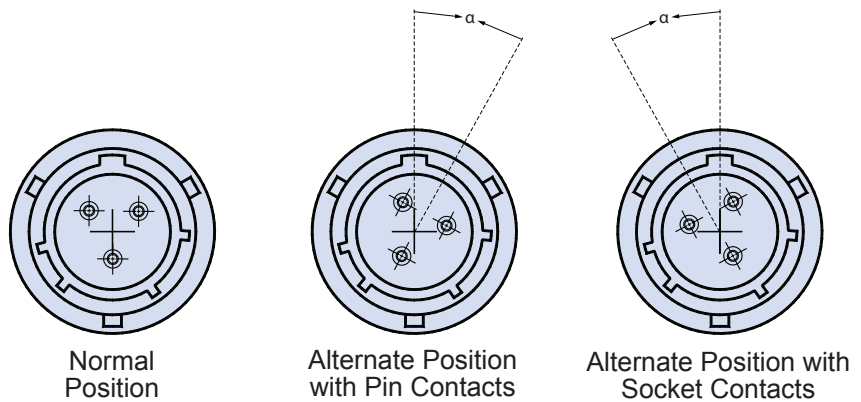

MATERIALS	
SHELLS	INSERTS (Temperature Range)
Aluminum Alloy IAW QQ-A-591 Shells	High Insulation Synthetic Rubber (Chloroprene): -55°C/+125°C
Stainless Steel Coupling Pins	CRIMP CONTACTS
Stainless Steel Spring	Copper Alloy with Gold Plating Over Nickel

STANDARD FINISH (For QQ-A-591 Aluminum Shells)	
Requirements	Cadmium with Olive Drab Passivation IAW QQ-P-416
Thermal Shock	-55°C + 125°C
Salt Spray After Thermal Shock	500 hour
Electrical Conductivity	Very Good
Abrasion Resistance	Very Good

VG95328 M
Bayonet-Lock
Straight Plug Connector
with Ground-Fingers and EMI Shrink-Boot Backshell

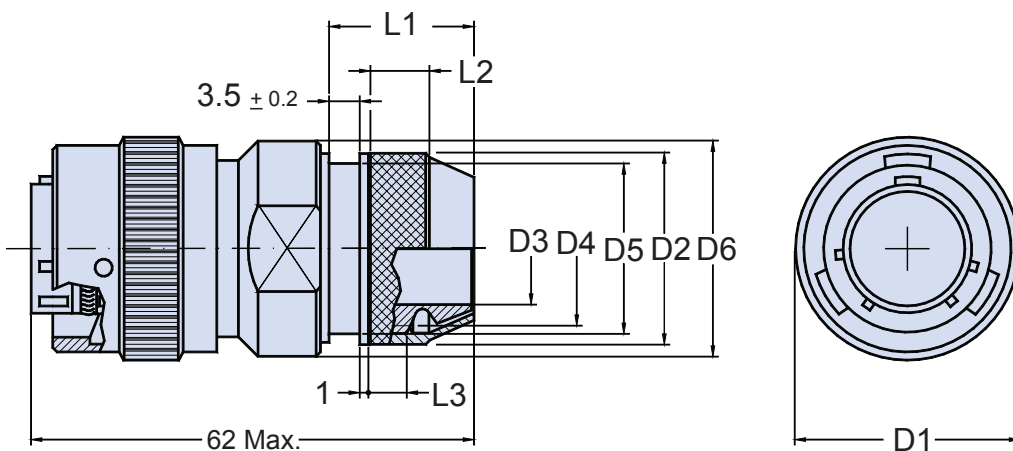
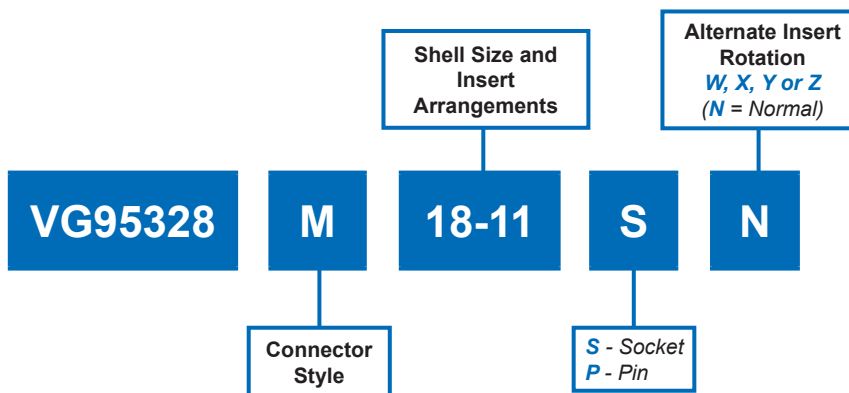

TABLE I: DIMENSIONS

Shell size	D1 Max.	D2 + 0.5 - 0	D3 Min.	D4	D5 + 0 - 1	D6 Max.	L1 + 0 - 2.5	L2 + 1.5 - 0	L3 Min.	Maximum Weight in Grams
8	19.8	16	6.6	M14 x 1	14.0	20	17	5	4	27
10	23.5	18	9.2	M16 x 1	16.0	23	17	5	4	29
12	26.5	22	12.2	M20 x 1	20.0	27	17	7	5	35
14	30.0	25	15.2	M23 x 1	23.0	30	18	8	6	45
16	33.1	28	18.3	M26 x 1	26.0	33	18	8	6	52
18	35.3	32	20.0	M30 x 1	28.5	36	18	10	6	67
20	38.8	34	23.0	M32 x 1	30.5	40	18	10	6	84
22	42.0	38	26.0	M36 x 1	34.5	43	18	10	6	102
24	45.1	41	28.8	M39 x 1	37.5	46	18	10	6	109

VG95328 M
Bayonet-Lock
Straight Plug Connector
 with Ground-Fingers and EMI Shrink-Boot Backshell



VG95328
Connectors

Contact Arrangements			
Arrangement	Cl. Isol. Rating	Dim. contact size	
		20	16
8 - 3A	I	3	
10 - 6	I	6	
12 - 3	II		3
12 - 10	I	10	
14 - 5	II		5
14 - 12	I	8	4
14 - 15	I	14	1
14 - 19	I	19	
16 - 8	II		8
16 - 23	I	22	1
16 - 26	I	26	
18 - 11	II		11
18 - 32	I	32	
20 - 16	II		16
20 - 41	I	41	
22 - 21	II		21
22 - 55	I	55	
24 - 61	I	61	

Alternate Insert Orientations				
Arrangement	Degrees			
	W	X	Y	Z
8 - 3A	60	(120)		
10 - 6	90			
12 - 3			180	
12 - 10	60	155	270	295
14 - 5	40	92	184	273
14 - 12	43	90		
14 - 15	17	110	155	234
14 - 19	30	165	315	
16 - 8	54	152	180	331
16 - 23	158	270		
16 - 26	60		275	338
18 - 11	62	119	241	340
18 - 32	85	138	222	265
20 - 16	238	318	333	347
20 - 41	45	126	225	
22 - 21	16	135	175	349
22 - 55	30	142	226	314
24 - 61	90	180	270	324

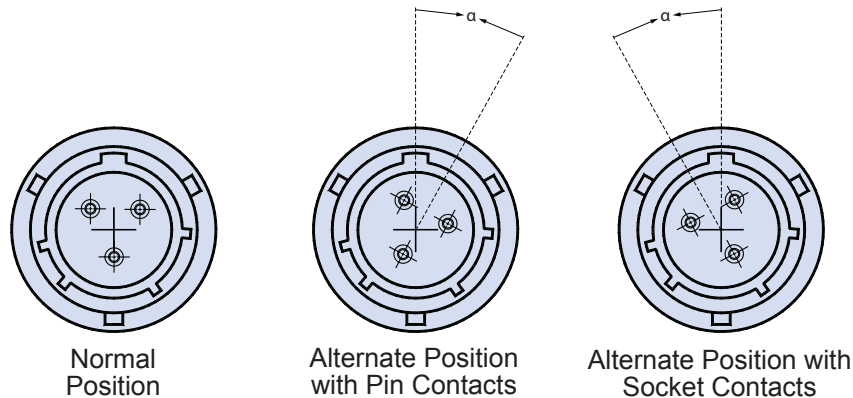

MATERIALS	
SHELLS	INSERTS (Temperature Range)
Aluminum Alloy IAW QQ-A-591 Shells	High Insulation Synthetic Rubber (Chloroprene): -55°C/+125°C
Stainless Steel Coupling Pins	CRIMP CONTACTS
Stainless Steel Spring	Copper Alloy with Gold Plating Over Nickel

STANDARD FINISH (For QQ-A-591 Aluminum Shells)	
Requirements	Cadmium with Olive Drab Passivation IAW QQ-P-416
Thermal Shock	-55°C + 125°C
Salt Spray After Thermal Shock	500 hour
Electrical Conductivity	Very Good
Abrasion Resistance	Very Good

VG95328 N
Bayonet-Lock
Straight Plug Connector
 with Backshell to Accommodate MS3057 Cable Clamp

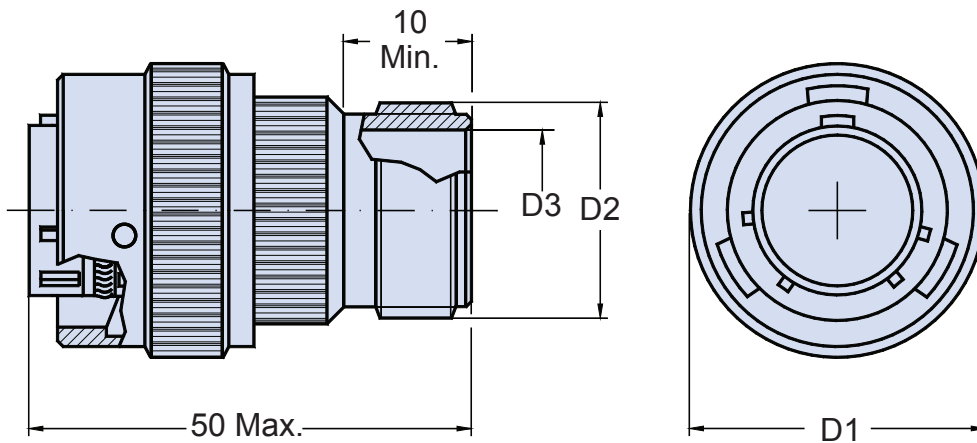
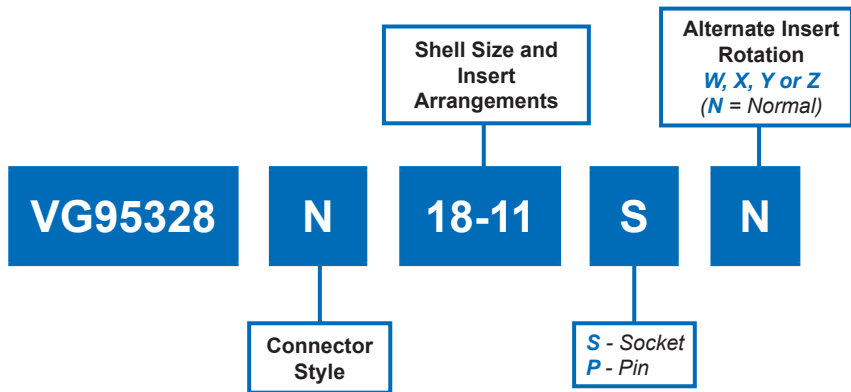

TABLE I: DIMENSIONS

Shell size	D1 Max.	D2	D3 Min.	Maximum Weight in Grams
8	19.8	0.5000 - 28UNEF	6.6	22
10	23.5	0.6250 - 24UNEF	9.2	22
12	26.5	0.7500 - 20UNEF	12.2	28
14	30.0	0.8750 - 20UNEF	15.2	38
16	33.1	1.0000 - 20UNEF	18.3	45
18	35.3	1.1875 - 18UNEF	20.0	60
20	38.8	1.1875 - 18UNEF	23.0	77
22	42.0	1.4375 - 18UNEF	26.0	95
24	45.1	1.4375 - 18UNEF	28.8	102

Cable Clamp Sold Separately

VG95328 N Bayonet-Lock Straight Plug Connector with Backshell to Accommodate MS3057 Cable Clamp



VG95328
Connectors

Contact Arrangements			
Arrangement	Cl. Isol. Rating	Dim. contact size	
		20	16
8 - 3A	I	3	
10 - 6	I	6	
12 - 3	II		3
12 - 10	I	10	
14 - 5	II		5
14 - 12	I	8	4
14 - 15	I	14	1
14 - 19	I	19	
16 - 8	II		8
16 - 23	I	22	1
16 - 26	I	26	
18 - 11	II		11
18 - 32	I	32	
20 - 16	II		16
20 - 41	I	41	
22 - 21	II		21
22 - 55	I	55	
24 - 61	I	61	

Alternate Insert Orientations				
Arrangement	Degrees			
	W	X	Y	Z
8 - 3A	60	(120)		
10 - 6	90			
12 - 3			180	
12 - 10	60	155	270	295
14 - 5	40	92	184	273
14 - 12	43	90		
14 - 15	17	110	155	234
14 - 19	30	165	315	
16 - 8	54	152	180	331
16 - 23	158	270		
16 - 26	60		275	338
18 - 11	62	119	241	340
18 - 32	85	138	222	265
20 - 16	238	318	333	347
20 - 41	45	126	225	
22 - 21	16	135	175	349
22 - 55	30	142	226	314
24 - 61	90	180	270	324

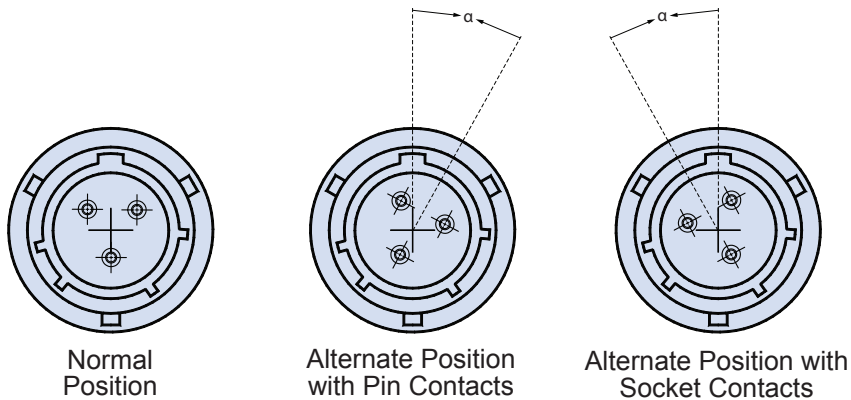

MATERIALS	
SHELLS	INSERTS (Temperature Range)
Aluminum Alloy IAW QQ-A-591 Shells	High Insulation Synthetic Rubber (Chloroprene): -55°C/+125°C
Stainless Steel Coupling Pins	CRIMP CONTACTS
Stainless Steel Spring	Copper Alloy with Gold Plating Over Nickel

STANDARD FINISH (For QQ-A-591 Aluminum Shells)	
Requirements	Cadmium with Olive Drab Passivation IAW QQ-P-416
Thermal Shock	-55°C + 125°C
Salt Spray After Thermal Shock	500 hour
Electrical Conductivity	Very Good
Abrasion Resistance	Very Good

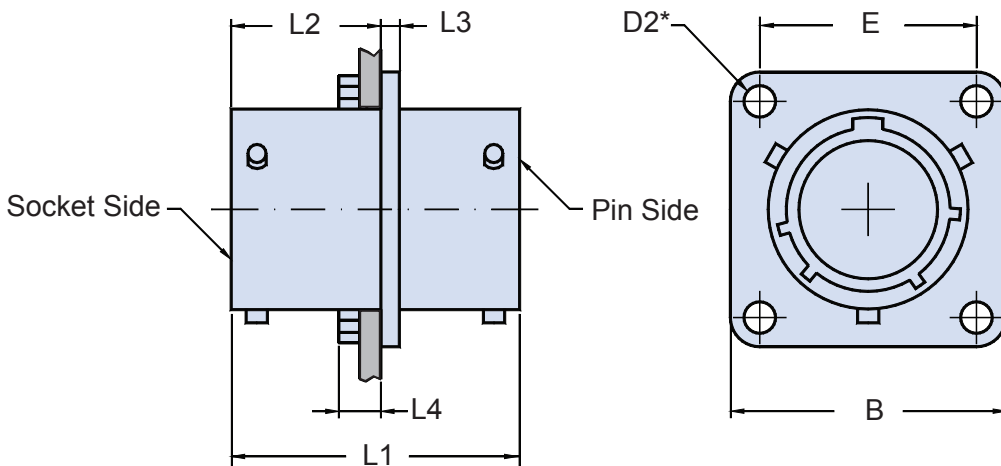
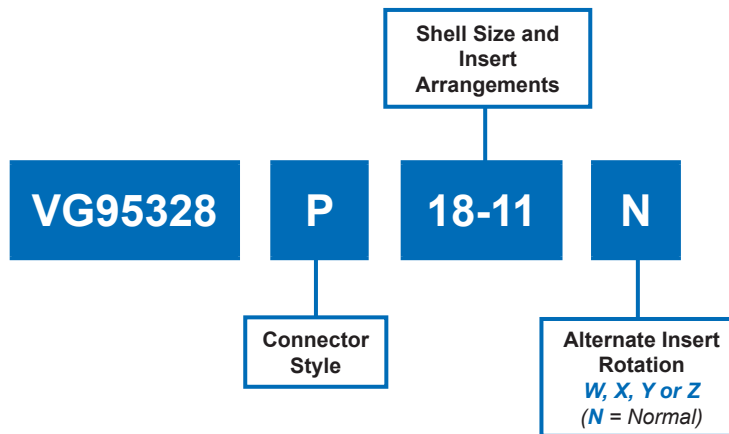

TABLE I: DIMENSIONS

Shell size	B Max.	D2 * Min.	E ± 0.15	L1 Max.	L2 + 0.79 - 0	L3 ± 0.4	L4 Max.	Maximum Weight in Grams
8	21.03	2.9	15.08	29	14.27	1.57	5.54	10
10	24.23	2.9	18.26	29	14.27	1.57	5.54	11
12	26.59	2.9	20.62	29	14.27	1.57	5.54	14
14	28.98	2.9	23.01	29	14.27	1.57	5.54	16
16	31.34	2.9	24.61	29	14.27	1.57	5.54	18
18	33.73	2.9	26.97	29	14.27	1.57	5.54	21
20	36.90	2.9	29.36	36	17.47	2.39	8.74	25
22	40.08	2.9	31.75	36	17.47	2.39	8.74	29
24	43.25	3.6	34.92	36	17.47	2.39	7.90	31

* Through Mounting Holes

VG95328 P Bayonet-Lock Rear Mount Square Flange Through Bulkhead Receptacle Pre-Assembled with Solid Contacts



VG95328
Connectors

Contact Arrangements			
Arrangement	Cl. Isol. Rating	Dim. contact size	
		20	16
8 - 3A	I	3	
10 - 6	I	6	
12 - 3	II		3
12 - 10	I	10	
14 - 5	II		5
14 - 12	I	8	4
14 - 15	I	14	1
14 - 19	I	19	
16 - 8	II		8
16 - 23	I	22	1
16 - 26	I	26	
18 - 11	II		11
18 - 32	I	32	
20 - 16	II		16
20 - 41	I	41	
22 - 21	II		21
22 - 55	I	55	
24 - 61	I	61	

Alternate Insert Orientations				
Arrangement	Degrees			
	W	X	Y	Z
8 - 3A	60	(120)		
10 - 6	90			
12 - 3			180	
12 - 10	60	155	270	295
14 - 5	40	92	184	273
14 - 12	43	90		
14 - 15	17	110	155	234
14 - 19	30	165	315	
16 - 8	54	152	180	331
16 - 23	158	270		
16 - 26	60		275	338
18 - 11	62	119	241	340
18 - 32	85	138	222	265
20 - 16	238	318	333	347
20 - 41	45	126	225	
22 - 21	16	135	175	349
22 - 55	30	142	226	314
24 - 61	90	180	270	324

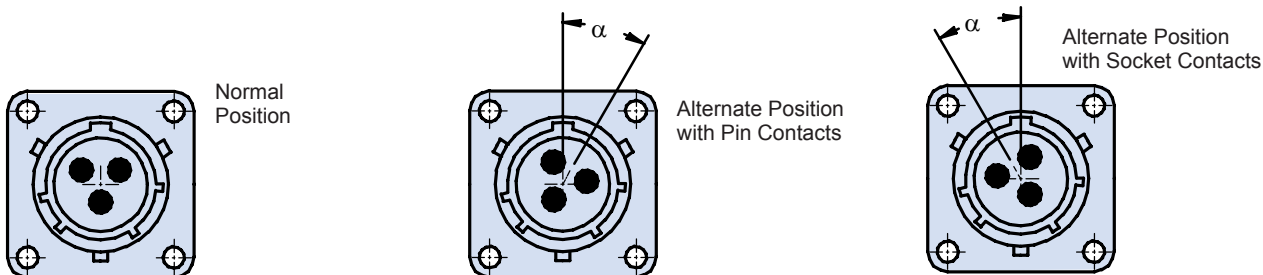

MATERIALS	
SHELLS	INSERTS (Temperature Range)
Aluminum Alloy IAW QQ-A-591 Shells	High Insulation Synthetic Rubber (Chloroprene): -55°C/+125°C
Stainless Steel Coupling Pins	SOLID CONTACTS
Stainless Steel Spring	Copper Alloy with Gold Plating Over Nickel

STANDARD FINISH (For QQ-A-591 Aluminum Shells)	
Requirements	Cadmium with Olive Drab Passivation IAW QQ-P-416
Thermal Shock	-55°C + 125°C
Salt Spray After Thermal Shock	500 hour
Electrical Conductivity	Very Good
Abrasion Resistance	Very Good

See Page 13 for Panel Thickness and Cutout Dimensions

VG95328 R
Bayonet-Lock
Front Panel Mount Square Flange Receptacle
with Backshell for EMI Shield Termination and Shrink Boot

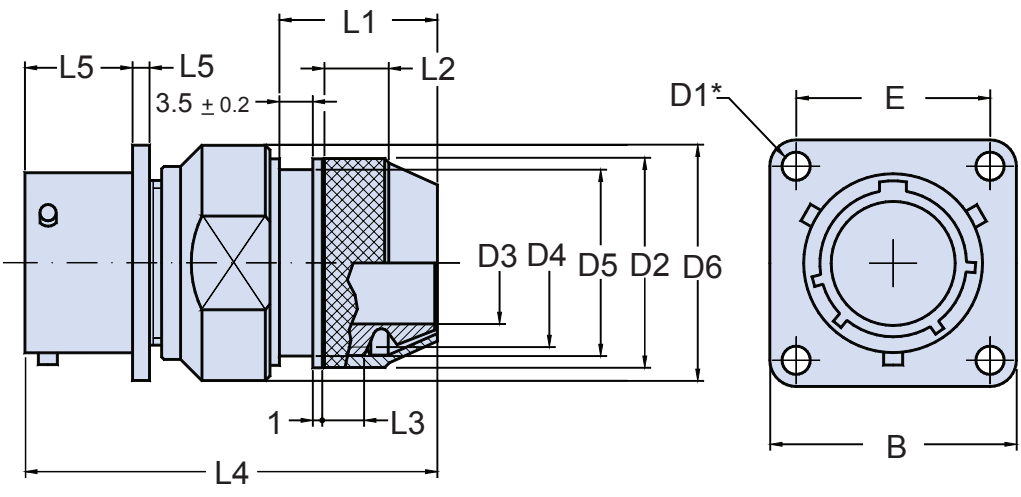
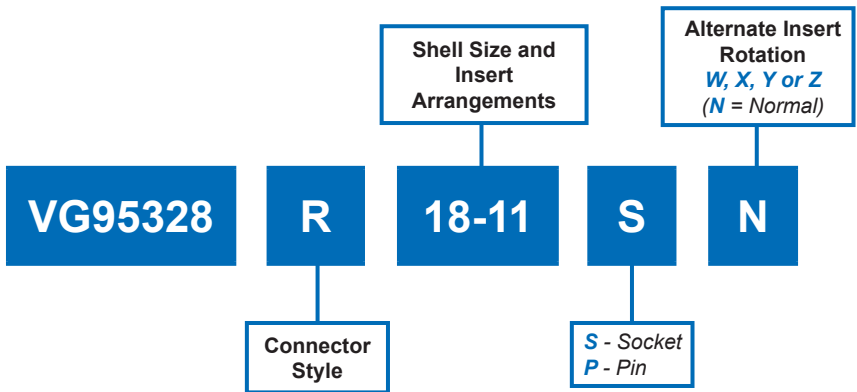

TABLE I: DIMENSIONS							
Shell size	B Max.	D1 * Min.	E ± 0.15	L4 Max.	L5 + 0.8 - 0	L6 Max.	Maximum Weight in Grams
8	21.03	2.9	15.08	54	10.94	2.0	26
10	24.23	2.9	18.26	54	10.94	2.0	32
12	26.59	2.9	20.62	54	10.94	2.0	38
14	28.98	2.9	23.01	54	10.94	2.0	44
16	31.34	2.9	24.61	54	10.94	2.0	49
18	33.73	2.9	26.97	54	10.94	2.0	60
20	36.90	2.9	29.36	62	14.12	2.8	70
22	40.08	2.9	31.75	62	14.12	2.8	73
24	43.25	3.6	34.92	62	14.96	2.8	87

For D2, D3, D4, D5, D6, L1, L2, and L3 Dimensions Please See VG95328 M

* Through Mounting Holes

VG95328 R
Bayonet-Lock
Front Panel Mount Square Flange Receptacle
with Backshell for EMI Shield Termination and Shrink Boot



VG95328
Connectors

Contact Arrangements			
Arrangement	Cl. Isol. Rating	Dim. contact size	
		20	16
8 - 3A	I	3	
10 - 6	I	6	
12 - 3	II		3
12 - 10	I	10	
14 - 5	II		5
14 - 12	I	8	4
14 - 15	I	14	1
14 - 19	I	19	
16 - 8	II		8
16 - 23	I	22	1
16 - 26	I	26	
18 - 11	II		11
18 - 32	I	32	
20 - 16	II		16
20 - 41	I	41	
22 - 21	II		21
22 - 55	I	55	
24 - 61	I	61	

Alternate Insert Orientations				
Arrangement	Degrees			
	W	X	Y	Z
8 - 3A	60	(120)		
10 - 6	90			
12 - 3			180	
12 - 10	60	155	270	295
14 - 5	40	92	184	273
14 - 12	43	90		
14 - 15	17	110	155	234
14 - 19	30	165	315	
16 - 8	54	152	180	331
16 - 23	158	270		
16 - 26	60		275	338
18 - 11	62	119	241	340
18 - 32	85	138	222	265
20 - 16	238	318	333	347
20 - 41	45	126	225	
22 - 21	16	135	175	349
22 - 55	30	142	226	314
24 - 61	90	180	270	324

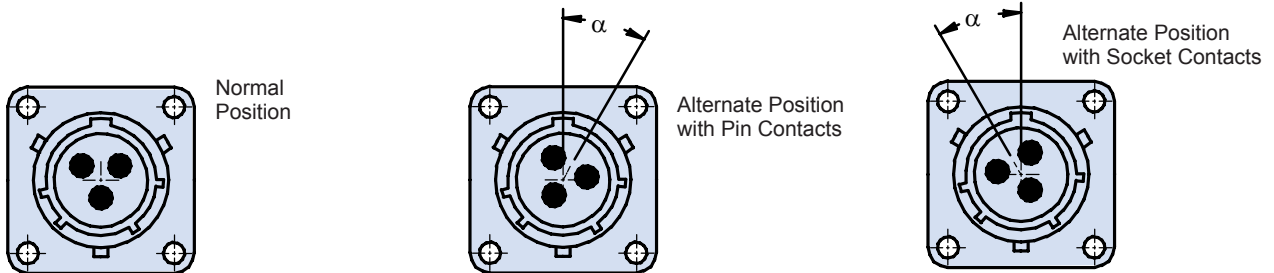

MATERIALS	
SHELLS	INSERTS (Temperature Range)
Aluminum Alloy IAW QQ-A-591 Shells	High Insulation Synthetic Rubber (Chloroprene): -55°C/+125°C
Stainless Steel Coupling Pins	CRIMP CONTACTS
Stainless Steel Spring	Copper Alloy with Gold Plating Over Nickel

STANDARD FINISH (For QQ-A-591 Aluminum Shells)	
Requirements	Cadmium with Olive Drab Passivation IAW QQ-P-416
Thermal Shock	-55°C + 125°C
Salt Spray After Thermal Shock	500 hour
Electrical Conductivity	Very Good
Abrasion Resistance	Very Good

See Page 13 for Panel Thickness and Cutout Dimensions

VG95328 S
Bayonet-Lock
Rear Panel Mount Jam Nut Receptacle Connector
with Shrinkboot Backshell

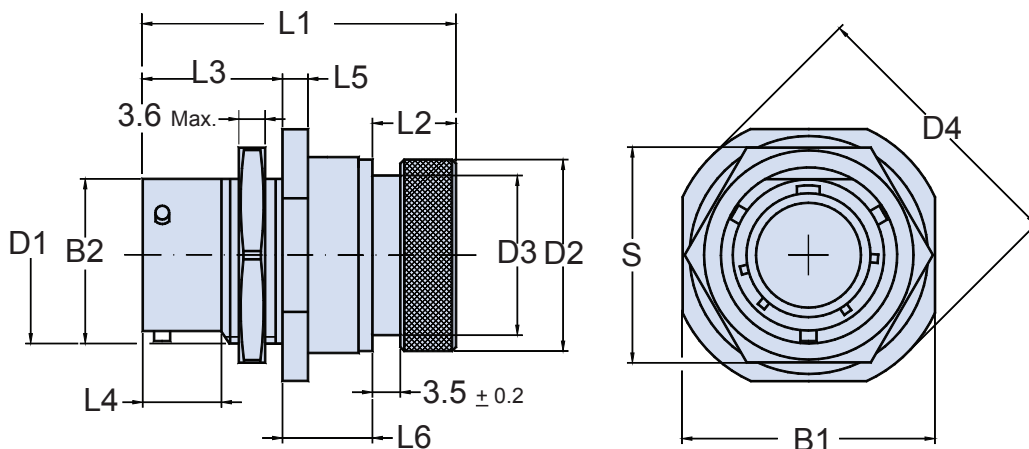
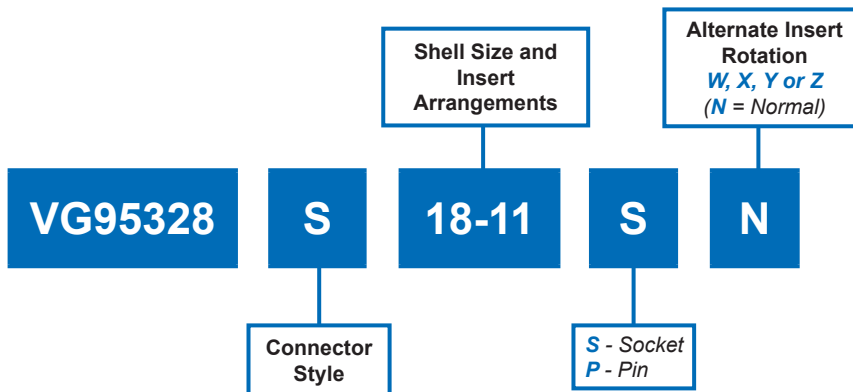

TABLE I: DIMENSIONS

Shell size	B1 Max.	B2 + 0 - 0.25	D1	D4 + 0 - 0.8	L1 Max.	L3 + 0.8 - 0	L4 Min.	L5 ± 0.5	L6 ± 0.8	S ± 0.43	Maximum Weight in Grams
8	24.3	13.46	0.5625-24UNEF	27.3	43.0	17.5	9.75	3.0	12.6	19.05	20
10	27.4	16.46	0.6875-24UNEF	30.5	43.0	17.5	9.75	3.0	12.6	22.23	23
12	32.2	20.78	0.8750-20UNEF	35.3	43.0	17.5	9.75	3.0	12.6	26.97	30
14	35.4	23.93	1.0000-20UNEF	38.5	43.0	17.5	9.75	3.0	12.6	30.18	40
16	38.6	27.08	1.1250-18UNEF	41.6	45.5	17.5	9.75	3.0	12.6	33.32	50
18	41.7	30.25	1.2500-18UNEF	44.8	45.5	17.5	9.75	3.0	12.6	36.53	60
20	46.5	33.43	1.3750-18UNEF	49.6	53.5	22.3	11.32	3.8	13.7	39.67	80
22	49.7	36.60	1.5000-18UNEF	52.7	53.5	22.3	11.32	3.8	13.7	42.88	85
24	52.8	39.78	1.6250-18UNEF	55.9	53.5	23.1	12.16	3.8	14.0	46.02	90

Single Hole Mounting

VG95328 S
Bayonet-Lock
Rear Panel Mount Jam Nut Receptacle Connector
with Shrinkboot Backshell



VG95328
Connectors

Contact Arrangements			
Arrangement	Cl. Isol. Rating	Dim. contact size	
		20	16
8 - 3A	I	3	
10 - 6	I	6	
12 - 3	II		3
12 - 10	I	10	
14 - 5	II		5
14 - 12	I	8	4
14 - 15	I	14	1
14 - 19	I	19	
16 - 8	II		8
16 - 23	I	22	1
16 - 26	I	26	
18 - 11	II		11
18 - 32	I	32	
20 - 16	II		16
20 - 41	I	41	
22 - 21	II		21
22 - 55	I	55	
24 - 61	I	61	

Alternate Insert Orientations				
Arrangement	Degrees			
	W	X	Y	Z
8 - 3A	60	(120)		
10 - 6	90			
12 - 3			180	
12 - 10	60	155	270	295
14 - 5	40	92	184	273
14 - 12	43	90		
14 - 15	17	110	155	234
14 - 19	30	165	315	
16 - 8	54	152	180	331
16 - 23	158	270		
16 - 26	60		275	338
18 - 11	62	119	241	340
18 - 32	85	138	222	265
20 - 16	238	318	333	347
20 - 41	45	126	225	
22 - 21	16	135	175	349
22 - 55	30	142	226	314
24 - 61	90	180	270	324

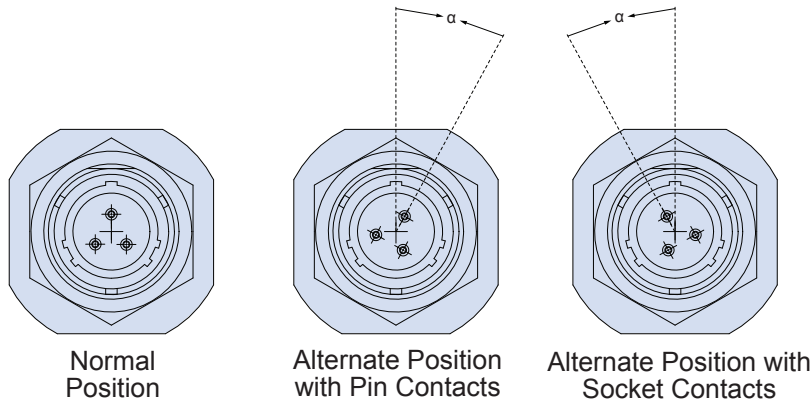

MATERIALS	
SHELLS	INSERTS (Temperature Range)
Aluminum Alloy IAW QQ-A-591 Shells	High Insulation Synthetic Rubber (Chloroprene): -55°C/+125°C
Stainless Steel Coupling Pins	CRIMP CONTACTS
Stainless Steel Spring	Copper Alloy with Gold Plating Over Nickel

STANDARD FINISH (For QQ-A-591 Aluminum Shells)	
Requirements	Cadmium with Olive Drab Passivation IAW QQ-P-416
Thermal Shock	-55°C + 125°C
Salt Spray After Thermal Shock	500 hour
Electrical Conductivity	Very Good
Abrasion Resistance	Very Good

See Page 13 for Panel Thickness and Cutout Dimensions

VG95328 T
Bayonet-Lock
Rear Panel Mount Jam Nut Receptacle
with Backshell for EMI Shield Termination and Shrink Boot

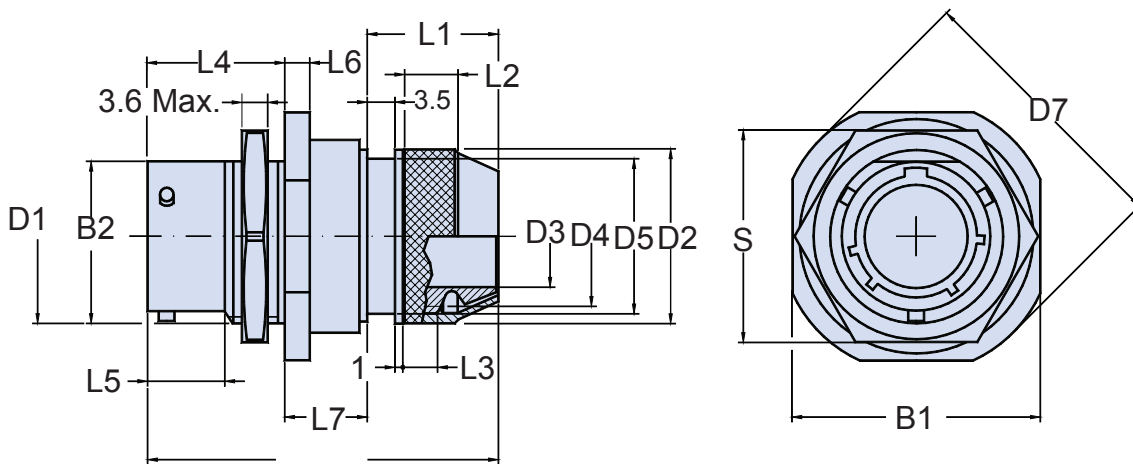
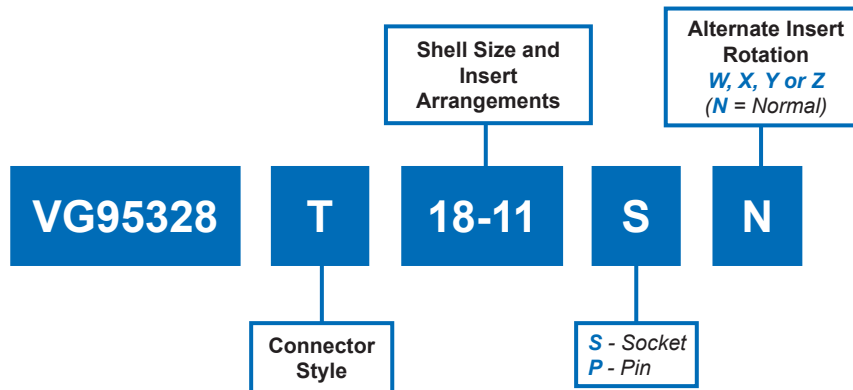

TABLE I: DIMENSIONS										
Shell size	B1 Max.	B2 +0 -0.25	D1	D7 +0 -0.8	L4 +0.8 -0	L5 Min.	L6 ±0.5	L7 ±0.8	S ±0.43	Maximum Weight in Grams
8	24.3	13.46	.5625 - 24 UNEF	27.3	17.5	9.75	3.0	12.6	19.05	30
10	27.4	16.64	.6875 - 24 UNEF	30.5	17.5	9.75	3.0	12.6	22.23	35
12	32.2	20.78	.8750 - 20 UNEF	35.3	17.5	9.75	3.0	12.6	26.97	45
14	35.4	23.93	1.0000 - 20 UNEF	38.5	17.5	9.75	3.0	12.6	30.18	55
16	38.6	27.08	1.1250 - 18 UNEF	41.6	17.5	9.75	3.0	12.6	33.32	65
18	41.7	30.25	1.2500 - 18 UNEF	44.8	17.5	9.75	3.0	12.6	36.53	80
20	46.5	33.43	1.3750 - 18 UNEF	49.6	22.3	11.32	3.8	13.7	39.67	105
22	49.7	36.60	1.5000 - 18 UNEF	52.7	22.3	11.32	3.8	13.7	42.88	115
24	52.8	39.78	1.6250 - 18 UNEF	55.9	23.1	12.16	3.8	14.0	46.02	125

For D2, D3, D4, D5, D6, L1, L2, and L3 Dimensions
Please See VG95328 M

Single Hole Mounting

VG95328 T Bayonet-Lock Rear Panel Mount Jam Nut Receptacle with Backshell for EMI Shield Termination and Shrink Boot



VG95328
Connectors

Contact Arrangements			
Arrangement	Cl. Isol. Rating	Dim. contact size	
		20	16
8 - 3A	I	3	
10 - 6	I	6	
12 - 3	II		3
12 - 10	I	10	
14 - 5	II		5
14 - 12	I	8	4
14 - 15	I	14	1
14 - 19	I	19	
16 - 8	II		8
16 - 23	I	22	1
16 - 26	I	26	
18 - 11	II		11
18 - 32	I	32	
20 - 16	II		16
20 - 41	I	41	
22 - 21	II		21
22 - 55	I	55	
24 - 61	I	61	

Alternate Insert Orientations				
Arrangement	Degrees			
	W	X	Y	Z
8 - 3A	60	(120)		
10 - 6	90			
12 - 3			180	
12 - 10	60	155	270	295
14 - 5	40	92	184	273
14 - 12	43	90		
14 - 15	17	110	155	234
14 - 19	30	165	315	
16 - 8	54	152	180	331
16 - 23	158	270		
16 - 26	60		275	338
18 - 11	62	119	241	340
18 - 32	85	138	222	265
20 - 16	238	318	333	347
20 - 41	45	126	225	
22 - 21	16	135	175	349
22 - 55	30	142	226	314
24 - 61	90	180	270	324

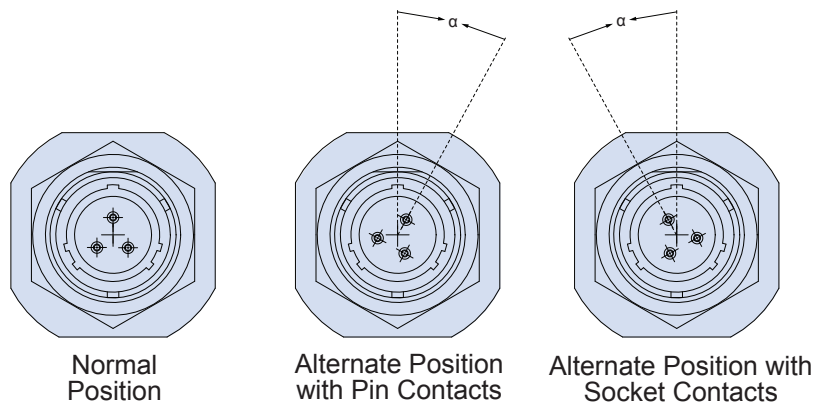

MATERIALS	
SHELLS	INSERTS (Temperature Range)
Aluminum Alloy IAW QQ-A-591 Shells	High Insulation Synthetic Rubber (Chloroprene): -55°C/+125°C
Stainless Steel Coupling Pins	CRIMP CONTACTS
Stainless Steel Spring	Copper Alloy with Gold Plating Over Nickel

STANDARD FINISH (For QQ-A-591 Aluminum Shells)	
Requirements	Cadmium with Olive Drab Passivation IAW QQ-P-416
Thermal Shock	-55°C + 125°C
Salt Spray After Thermal Shock	500 hour
Electrical Conductivity	Very Good
Abrasion Resistance	Very Good

See Page 13 for Panel Thickness and Cutout Dimensions

VG95328 U
Bayonet-Lock
Straight Plug Connector with Thumb-Lock Lever,
Grounding-Fingers and EMI/Shrinkboot Backshell

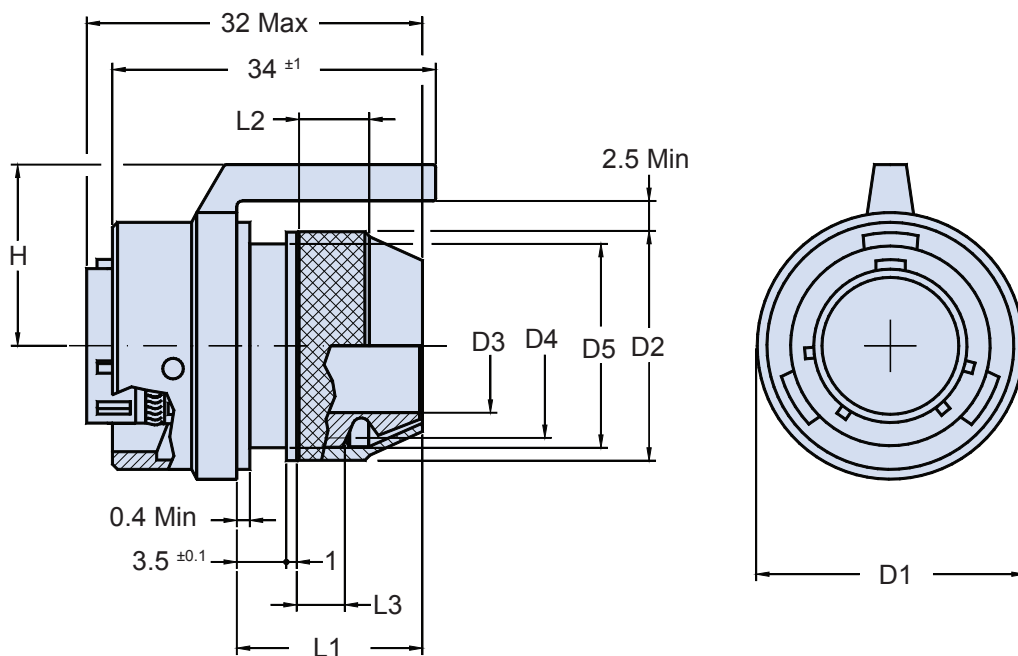
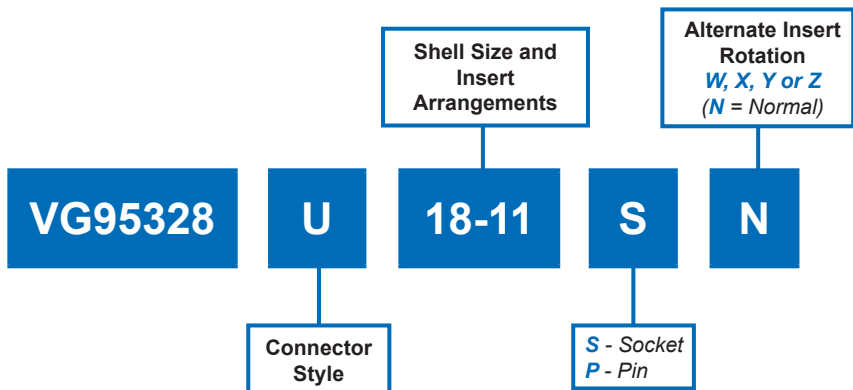

TABLE I: DIMENSIONS			
Shell Size	D1 ± 1	H ± 1	Maximum Weight in Grams
12	24	19	18
14	28	20	20
16	31	21	22

For D2, D3, D4, D5, L1, L2,
 and L3 Dimensions
 Please See VG95328 M

VG95328 U Bayonet-Lock Straight Plug Connector with Thumb-Lock Lever, Grounding-Fingers and EMI/Shrinkboot Backshell



VG95328
Connectors

Contact Arrangements			
Arrangement	Cl. Isol. Rating	Dim. contact size	
		20	16
8 - 3A	I	3	
10 - 6	I	6	
12 - 3	II		3
12 - 10	I	10	
14 - 5	II		5
14 - 12	I	8	4
14 - 15	I	14	1
14 - 19	I	19	
16 - 8	II		8
16 - 23	I	22	1
16 - 26	I	26	
18 - 11	II		11
18 - 32	I	32	
20 - 16	II		16
20 - 41	I	41	
22 - 21	II		21
22 - 55	I	55	
24 - 61	I	61	

Alternate Insert Orientations				
Arrangement	Degrees			
	W	X	Y	Z
8 - 3A	60	(120)		
10 - 6	90			
12 - 3			180	
12 - 10	60	155	270	295
14 - 5	40	92	184	273
14 - 12	43	90		
14 - 15	17	110	155	234
14 - 19	30	165	315	
16 - 8	54	152	180	331
16 - 23	158	270		
16 - 26	60		275	338
18 - 11	62	119	241	340
18 - 32	85	138	222	265
20 - 16	238	318	333	347
20 - 41	45	126	225	
22 - 21	16	135	175	349
22 - 55	30	142	226	314
24 - 61	90	180	270	324

Class L, U, and W Thumb-Lock versions not qualified to VG95328. Please consult factory for Glenair commercial equivalent VG95328 type Thumb-Lock connectors

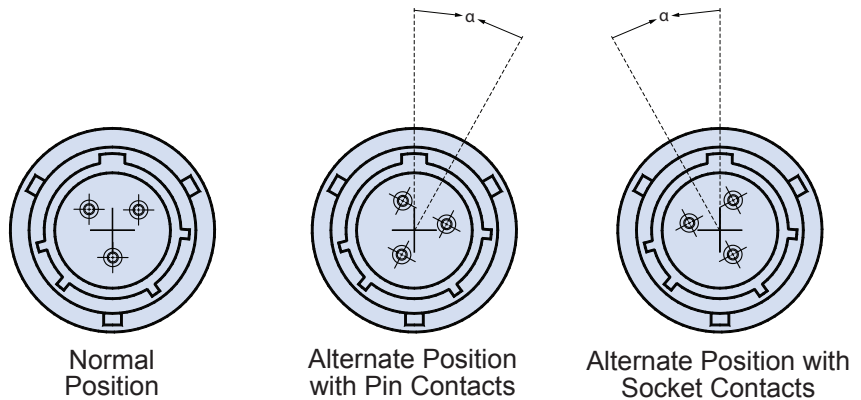

MATERIALS	
SHELLS	INSERTS (Temperature Range)
Aluminum Alloy IAW QQ-A-591 Shells	High Insulation Synthetic Rubber (Chloroprene): -55°C/+125°C
Stainless Steel Coupling Pins	CRIMP CONTACTS
Stainless Steel Spring	Copper Alloy with Gold Plating Over Nickel

STANDARD FINISH (For QQ-A-591 Aluminum Shells)	
Requirements	Cadmium with Olive Drab Passivation IAW QQ-P-416
Thermal Shock	-55°C + 125°C
Salt Spray After Thermal Shock	500 hour
Electical Conductivity	Very Good
Abrasion Resistance	Very Good

VG95328 V
Bayonet-Lock
Straight Plug Connector
with Ground-Fingers and EMI/Shrinkboot Backshell

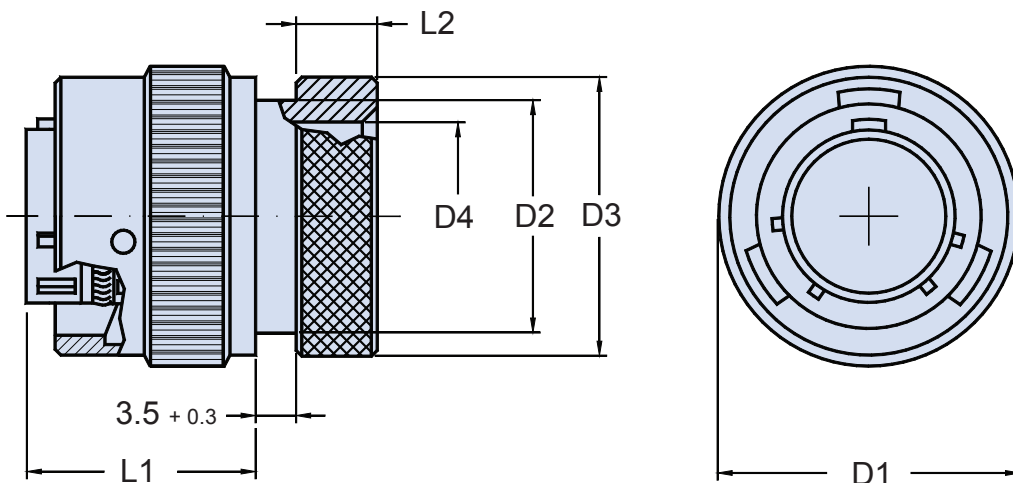
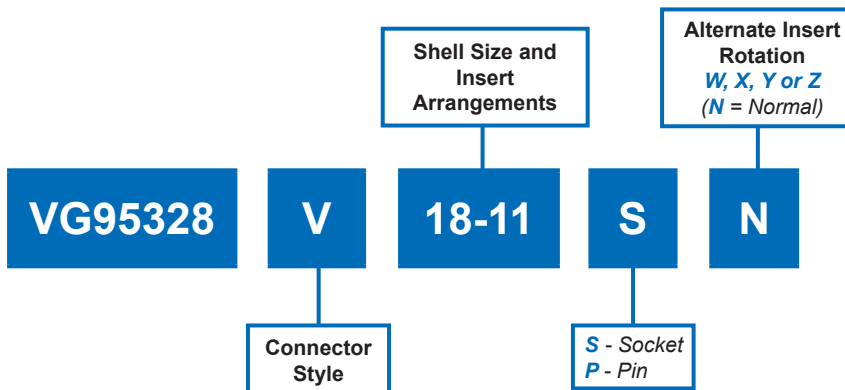

TABLE I: DIMENSIONS

Shell size	D1 Max.	D2 + 0.15 - 0	D3		D4		L1 Max.	L2 Min.	Maximum Weight in Grams
				Limit		Limit			
8	19.8	9.40	13.8	-2.00	7.0	+2.5	23	6.5	14
10	23.5	12.60	16.6	-1.60	10.4	+2.1	23	6.5	16
12	26.5	15.75	19.8	-1.65	13.9	+1.7	23	6.5	23
14	30.0	18.40	23.0	-2.20	16.5	+2.2	23	6.5	30
16	33.1	21.60	26.2	-2.20	19.7	+2.1	23	6.5	43
18	35.3	24.40	29.0	-2.20	22.3	+2.4	23	8.5	46
20	38.8	26.00	32.3	-2.30	25.5	+2.4	28	8.5	63
22	42.0	29.40	36.6	-2.20	28.7	+2.4	28	8.5	78
24	45.1	32.50	39.8	-3.30	31.8	+2.5	28	8.5	84

VG95328 V
Bayonet-Lock
Straight Plug Connector
with Ground-Fingers and EMI/Shrinkboot Backshell



VG95328
Connectors

Contact Arrangements			
Arrangement	Cl. Isol. Rating	Dim. contact size	
		20	16
8 - 3A	I	3	
10 - 6	I	6	
12 - 3	II		3
12 - 10	I	10	
14 - 5	II		5
14 - 12	I	8	4
14 - 15	I	14	1
14 - 19	I	19	
16 - 8	II		8
16 - 23	I	22	1
16 - 26	I	26	
18 - 11	II		11
18 - 32	I	32	
20 - 16	II		16
20 - 41	I	41	
22 - 21	II		21
22 - 55	I	55	
24 - 61	I	61	

Alternate Insert Orientations				
Arrangement	Degrees			
	W	X	Y	Z
8 - 3A	60	(120)		
10 - 6	90			
12 - 3			180	
12 - 10	60	155	270	295
14 - 5	40	92	184	273
14 - 12	43	90		
14 - 15	17	110	155	234
14 - 19	30	165	315	
16 - 8	54	152	180	331
16 - 23	158	270		
16 - 26	60		275	338
18 - 11	62	119	241	340
18 - 32	85	138	222	265
20 - 16	238	318	333	347
20 - 41	45	126	225	
22 - 21	16	135	175	349
22 - 55	30	142	226	314
24 - 61	90	180	270	324

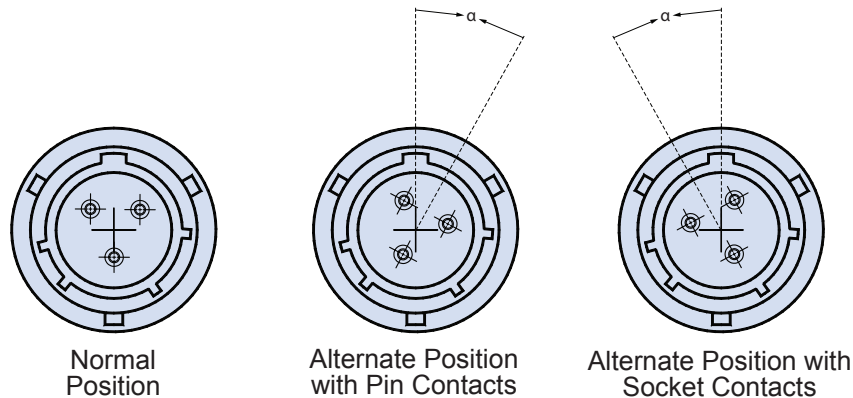

MATERIALS	
SHELLS	INSERTS (Temperature Range)
Aluminum Alloy IAW QQ-A-591 Shells	High Insulation Synthetic Rubber (Chloroprene): -55°C/+125°C
Stainless Steel Coupling Pins	CRIMP CONTACTS
Stainless Steel Spring	Copper Alloy with Gold Plating Over Nickel

STANDARD FINISH (For QQ-A-591 Aluminum Shells)	
Requirements	Cadmium with Olive Drab Passivation IAW QQ-P-416
Thermal Shock	-55°C + 125°C
Salt Spray After Thermal Shock	500 hour
Electrical Conductivity	Very Good
Abrasion Resistance	Very Good

VG95328 W
Bayonet-Lock
Straight Plug Connector with Thumb-Lock Lever,
Grounding-Fingers and EMI/Shrinkboot Backshell

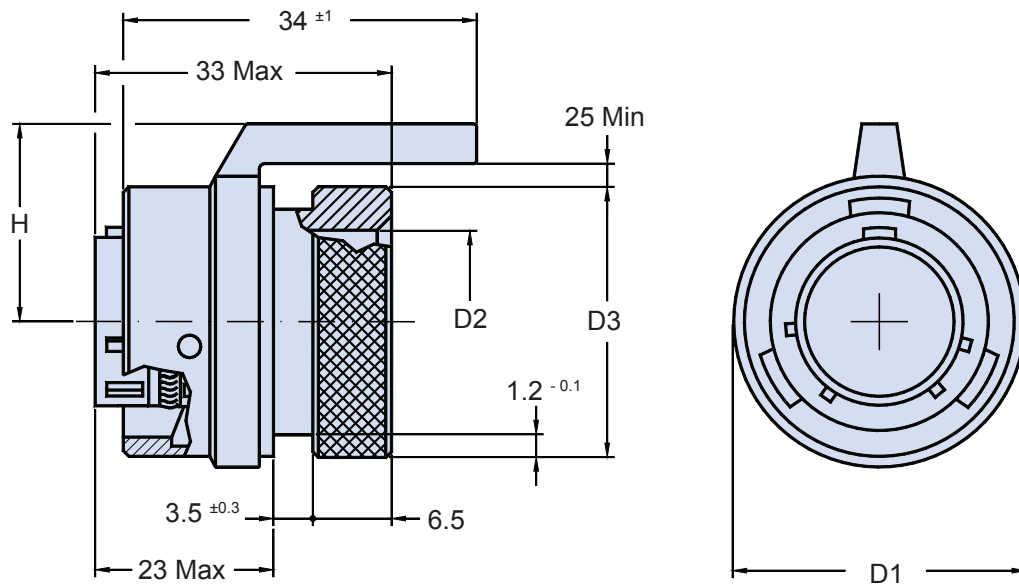
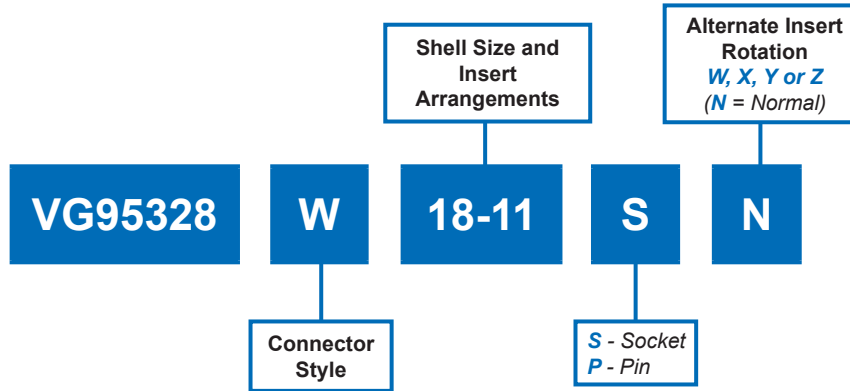

TABLE I: DIMENSIONS						
Shell Size	D1 ± 1	D2 ± 0.5	D3 ± 0.5		H ± 1	Maximum Weight in Grams
				Limit		
12	24	14.0	19.8	-1.65	18	16
14	28	17.1	23.0	-2.20	20	18
16	31	20.3	26.2	-2.20	21	20

VG95328 W Bayonet-Lock Straight Plug Connector with Thumb-Lock Lever, Grounding-Fingers and EMI/Shrinkboot Backshell



VG95328
Connectors

Contact Arrangements			
Arrangement	Cl. Isol. Rating	Dim. contact size	
		20	16
8 - 3A	I	3	
10 - 6	I	6	
12 - 3	II		3
12 - 10	I	10	
14 - 5	II		5
14 - 12	I	8	4
14 - 15	I	14	1
14 - 19	I	19	
16 - 8	II		8
16 - 23	I	22	1
16 - 26	I	26	
18 - 11	II		11
18 - 32	I	32	
20 - 16	II		16
20 - 41	I	41	
22 - 21	II		21
22 - 55	I	55	
24 - 61	I	61	

Alternate Insert Orientations				
Arrangement	Degrees			
	W	X	Y	Z
8 - 3A	60	(120)		
10 - 6	90			
12 - 3			180	
12 - 10	60	155	270	295
14 - 5	40	92	184	273
14 - 12	43	90		
14 - 15	17	110	155	234
14 - 19	30	165	315	
16 - 8	54	152	180	331
16 - 23	158	270		
16 - 26	60		275	338
18 - 11	62	119	241	340
18 - 32	85	138	222	265
20 - 16	238	318	333	347
20 - 41	45	126	225	
22 - 21	16	135	175	349
22 - 55	30	142	226	314
24 - 61	90	180	270	324

Class L, U, and W Thumb-Lock versions not qualified to VG95328. Please consult factory for Glenair commercial equivalent VG95328 type Thumb-Lock connectors

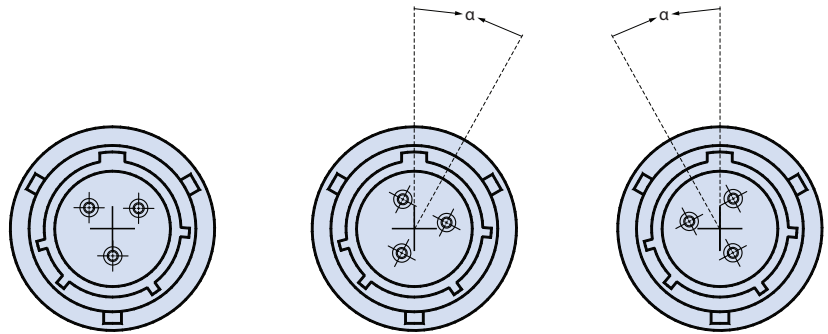

Normal Position
Alternate Position with Pin Contacts
Alternate Position with Socket Contacts

MATERIALS	
SHELLS	INSERTS (Temperature Range)
Aluminum Alloy IAW QQ-A-591 Shells	High Insulation Synthetic Rubber (Chloroprene): -55°C/+125°C
Stainless Steel Coupling Pins	CRIMP CONTACTS
Stainless Steel Spring	Copper Alloy with Gold Plating Over Nickel

STANDARD FINISH (For QQ-A-591 Aluminum Shells)	
Requirements	Cadmium with Olive Drab Passivation IAW QQ-P-416
Thermal Shock	-55°C + 125°C
Salt Spray After Thermal Shock	500 hour
Electical Conductivity	Very Good
Abrasion Resistance	Very Good

VG95328 Z1 A, B, and C
Receptacle Covers for Panel Attachment
For Connectors A to H and P, R, S and T Only

VG95328

Z1

A

18

Receptacle
Cover

Lanyard Style
A = Chain with
Eyelet
B = Rope with
Eyelet
C = Rope Sans
Eyelet

Shell Size

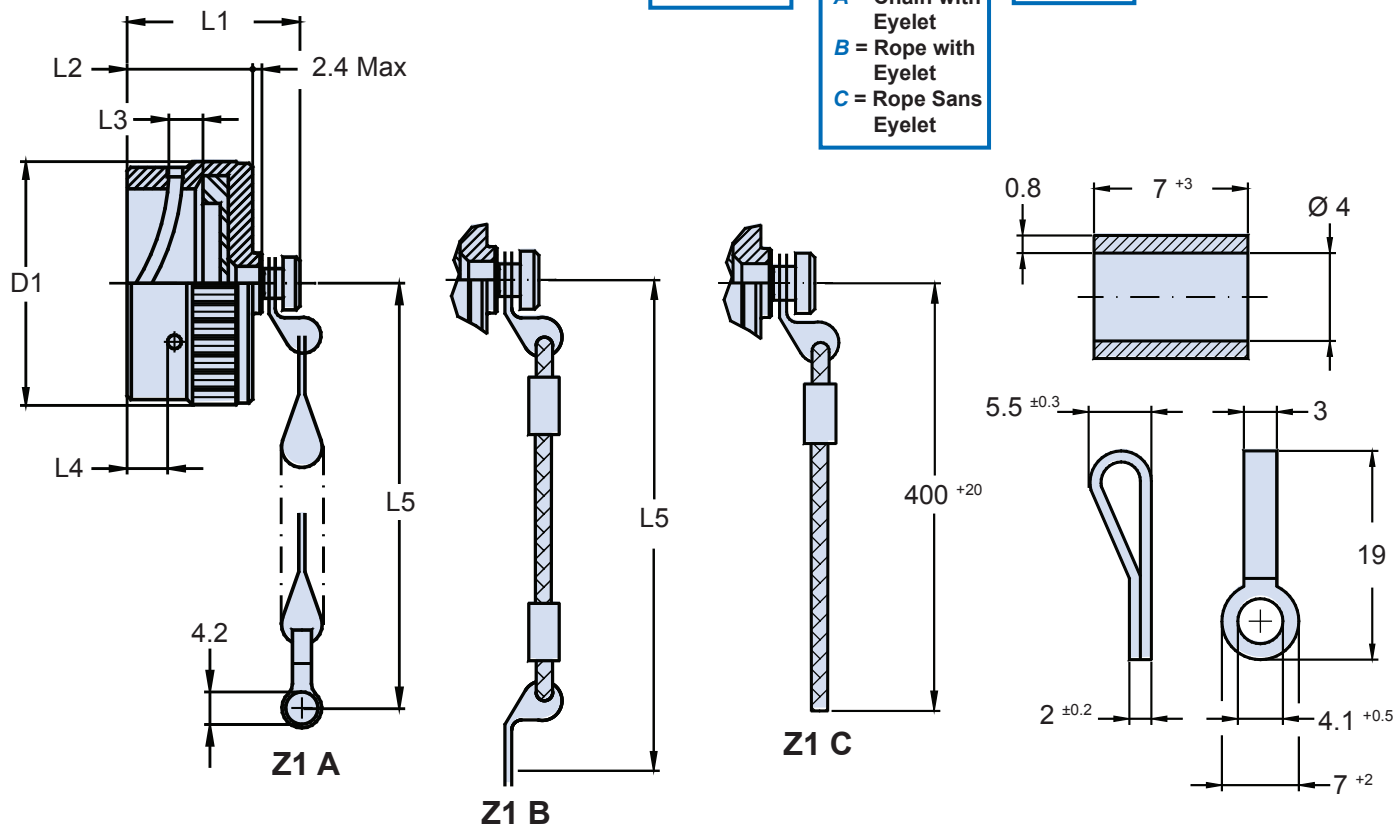

TABLE I: DIMENSIONS

Shell size	D1 Max.	L1 Max.	L2 Max.	L3 + 0.25 - 0.38	L4 Max.	L5 + 13 - 7	Maximum Weight in Grams
8	18.7	21.5	14.3	2.92	3.78	77	17
10	21.9	21.5	14.3	2.92	3.78	77	17
12	25.4	21.5	14.3	2.92	3.78	89	25
14	28.6	21.5	14.3	2.92	3.78	89	25
16	31.8	21.5	14.3	2.92	3.78	89	29
18	35.0	21.5	14.3	2.92	3.78	89	29
20	38.1	21.5	14.3	2.92	3.78	102	33
22	41.3	21.5	14.3	2.92	3.78	102	36
24	44.5	22.3	15.3	3.73	2.21	102	42

**VG95328 Z2 A, B, and C
Plug Covers for Panel Attachment
For Connectors J to N and U, V and W Only**



VG95328
Accessories

VG95328

Z2

A

18

Plug
Cover

Lanyard Style
A = Chain with Eyelet
B = Rope with Eyelet
C = Rope Sans Eyelet

Shell Size

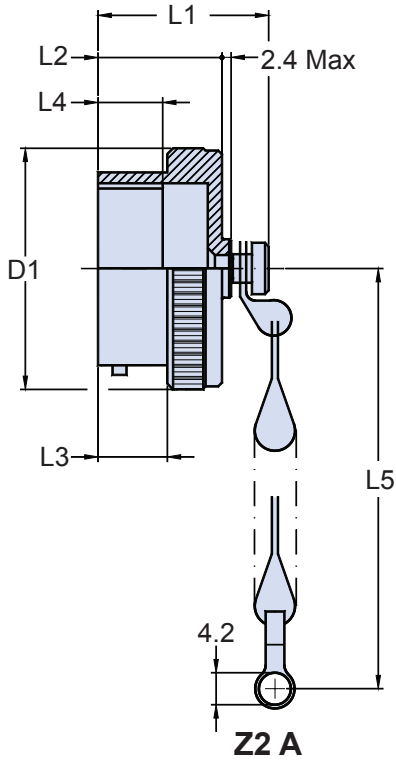

Z2 A

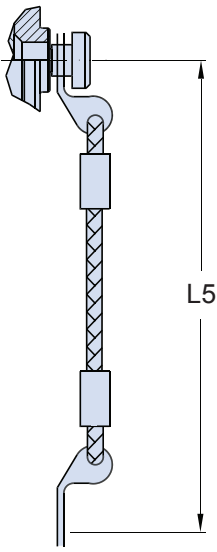

Z2 B

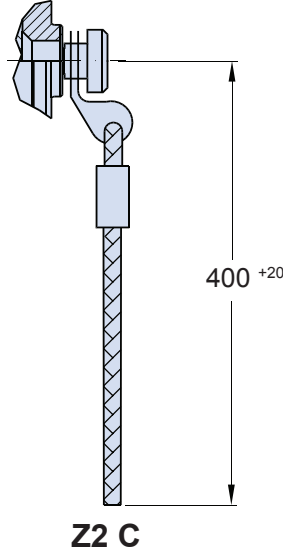

Z2 C

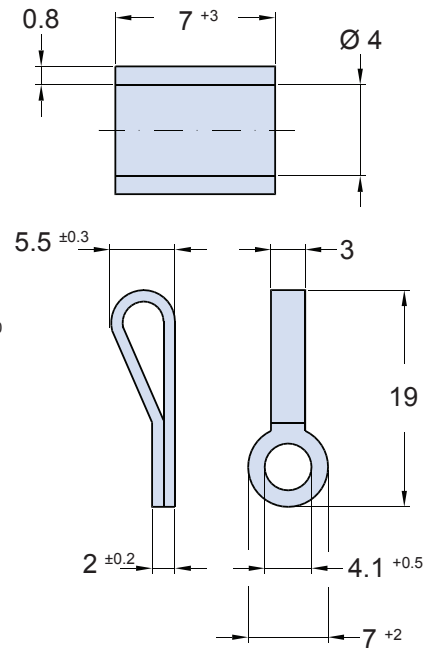

TABLE I: DIMENSIONS

Shell size	D1 Max.	L1 Max.	L2 Max.	L3 + 0.8 - 0	L4 + 0.25 - 0.5	L5 + 13 - 7	Maximum Weight in Grams
8	18.3	19.9	14.3	9.35	8.3	77	17
10	21.5	19.9	14.3	9.35	8.3	77	17
12	25.4	19.9	14.3	9.35	8.3	89	21
14	28.6	19.9	14.3	9.35	8.3	89	24
16	31.8	19.9	14.3	9.35	8.3	89	27
18	35.0	19.9	14.3	9.35	8.3	89	31
20	38.1	21.5	15.9	10.92	9.9	102	36
22	41.3	21.5	15.9	10.92	9.9	102	40
24	44.5	22.3	16.7	11.76	9.9	102	43

VG95328 Z3 C
Receptacle Cover For Cable Attachment
For Connectors D, E, F, S and T Only

VG95328 **Z3** **C** **18**

Receptacle Cover Lanyard Style
C = Rope with Connector Ring Shell Size

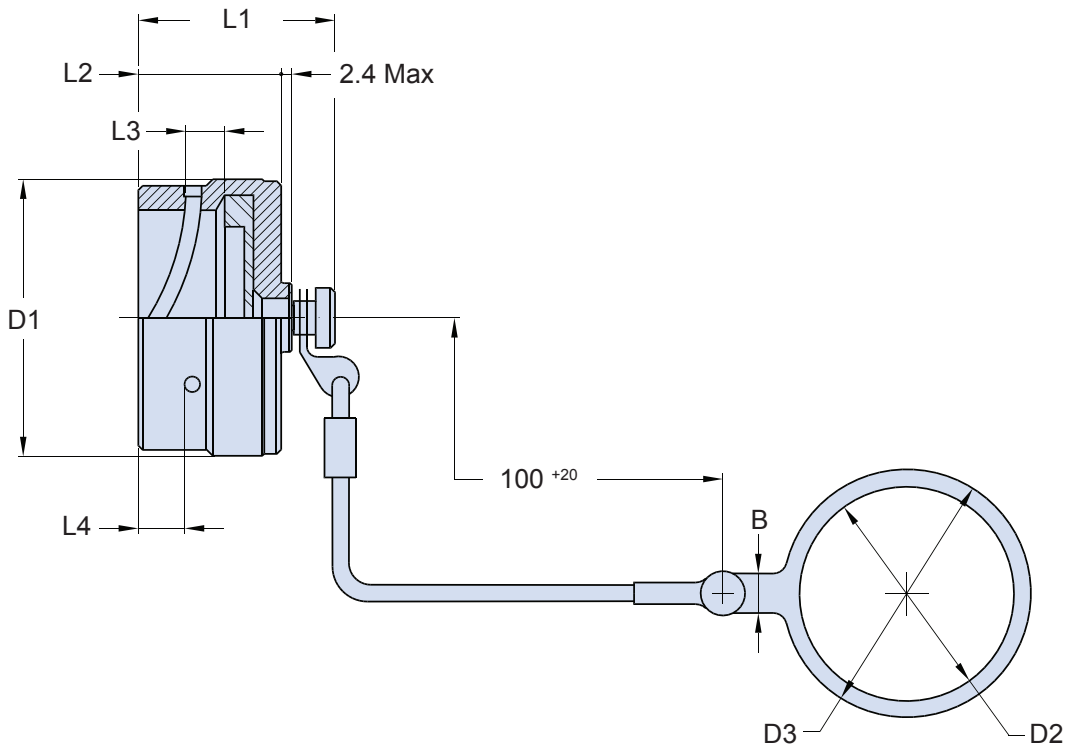
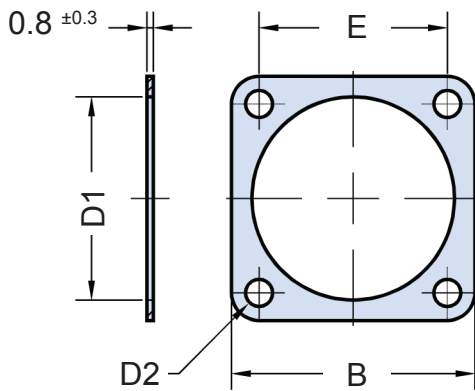
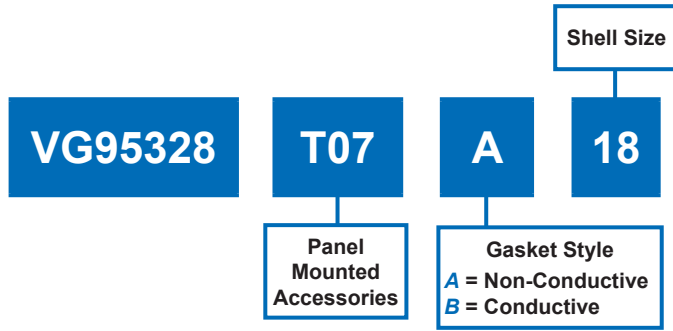

TABLE I: DIMENSIONS

Shell size	B Min.	D2 Min.	D3 Max.	Maximum Weight in Grams
8	5.94	14.68	20.62	17
10	5.94	17.86	25.40	17
12	5.94	22.63	30.18	25
14	5.94	25.81	36.53	25
16	5.94	28.98	39.67	29
18	5.94	32.16	42.88	29
20	5.94	35.33	46.02	33
22	5.94	38.51	49.23	36
24	5.94	41.68	52.37	42

L1, L2, L3, L4 and D1 dimensions: See Page 54

VG95328 T07 A and B
Conductive and Non-Conductive Gaskets
For Connectors A, B, C, H, P and R Only



VG95328 T07 A
Non-Conductive

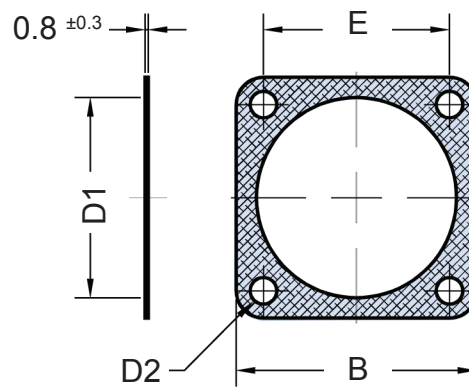

VG95328 T07 B
Conductive

TABLE I: DIMENSIONS

Shell size	B Max.	D1 +1 -0	D2 Min.	E ± 0.3	Maximum Weight in Grams
8	22.7	12.7	3.1	15.1	2
10	25.8	15.9	3.1	18.3	2
12	28.2	19.0	3.1	20.6	2
14	30.6	22.2	3.1	23.0	2
16	33.0	25.4	3.1	24.6	2
18	35.4	28.6	3.1	27.0	2
20	38.5	31.7	3.1	29.4	2
22	41.7	34.9	3.1	31.8	2
24	44.9	38.1	4.2	34.9	2

VG95328 T07 C Dummy Storage Receptacle Closed Back

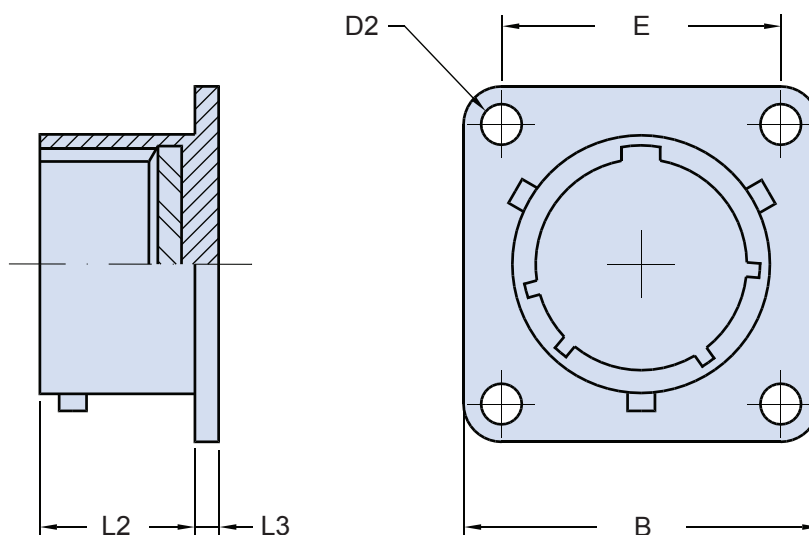
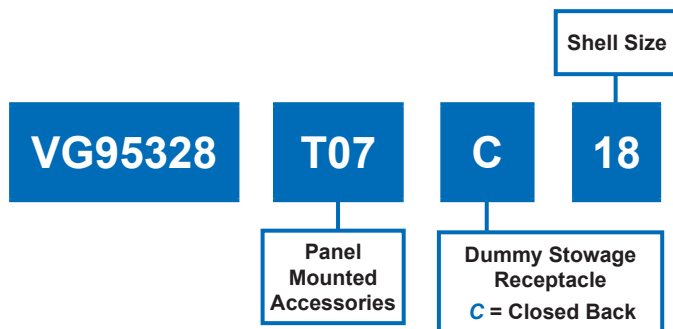

TABLE I: DIMENSIONS						
Shell size	B Max.	D2 Min.	E ± 0.15	L2 Max.	L3 Max.	Maximum Weight in Grams
8	21.03	2.9	15.08	12.5	2.0	8
10	24.23	2.9	18.26	12.5	2.0	10
12	26.59	2.9	20.62	12.5	2.0	12
14	28.98	2.9	23.01	12.5	2.0	14
16	31.34	2.9	24.61	12.5	2.0	16
18	33.73	2.9	26.97	12.5	2.0	18
20	36.90	2.9	29.36	15.0	2.8	20
22	40.08	2.9	31.75	15.0	2.8	25
24	43.25	3.6	34.92	15.0	2.8	30

VG95328 T07 D
Dummy Stowage Receptacle
Open Back

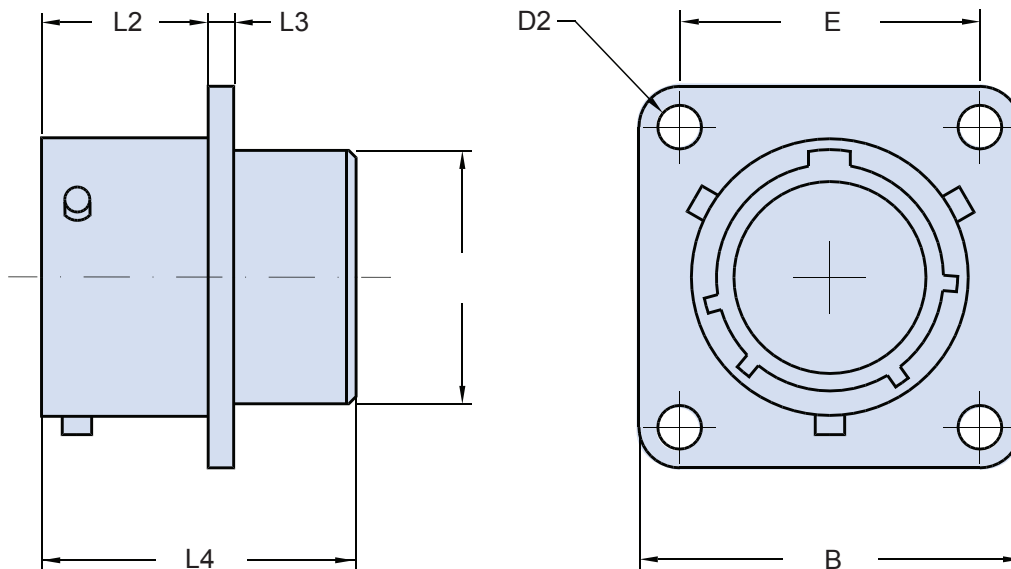
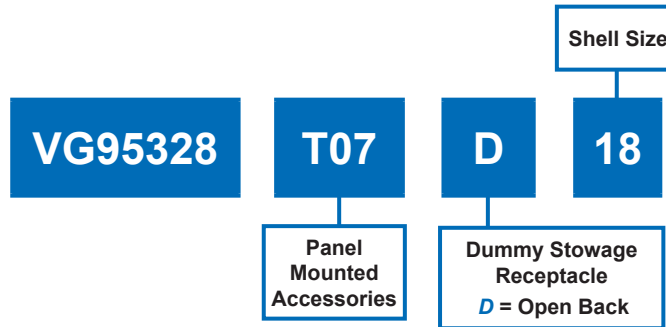

TABLE I: DIMENSIONS

Shell size	B Max.	D2 Min.	D3 + 0.8 - 0.6	E ± 0.15	L2 Max.	L3 Max.	L4 Max.	Maximum Weight in Grams
8	21.03	2.9	11.2	15.08	10.94	2.0	24.3	6
10	24.23	2.9	14.3	18.26	10.94	2.0	24.3	7
12	26.59	2.9	17.5	20.62	10.94	2.0	24.3	10
14	28.98	2.9	20.7	23.01	10.94	2.0	24.3	12
16	31.34	2.9	23.9	24.61	10.94	2.0	24.3	14
18	33.73	2.9	27.0	26.97	10.94	2.0	24.3	17
20	36.90	2.9	30.2	29.36	14.12	2.6	28.3	21
22	40.08	2.9	33.4	31.75	14.12	2.6	28.3	25
24	43.25	3.6	36.6	34.92	14.96	2.6	28.9	27

To Most People It's Just a Connector



To Glenair It's a Promise

Most customers have a simple expectation when they go shopping for safety-critical interconnect components: They want fast and accurate service. Glenair addresses this most basic customer requirement in several different ways. First and foremost, by providing immediate access to our technical information and product documentation: whether you prefer an office visit, the telephone, the Internet, a CD or a printed catalog, Glenair is ready with answers to your most complex questions and design challenges. Secondly, Glenair stocks thousands of popular catalog products for those situations

when even a two or three week lead-time is just too long. We stock over 65,000 interconnect components—bagged and tagged and ready for immediate shipment. And for those situations when a customized solution is required, our engineers are fully versed in all aspects of interconnect system design: from shielding against EMI, to reducing weight and connector package size, to stopping corrosion and other forms of environmental damage.

You have a simple expectation: fast and accurate service. At Glenair, we're ready to give you exactly that. It's a promise.



1211 Air Way

Glendale, California 91201-2497

Telephone: 818-247-6000 · Facsimilie: 818-500-9912 · EMail: sales@glenair.com

United States · United Kingdom · Germany · Nordic · France · Italy · Spain · Japan

www.glenair.com

The world's broadest selection of interconnect products—in stock and ready for immediate same-day shipment

Glenair's World of Interconnect Solutions

A complete overview of Glenair's innovative range of interconnect products and services, including Military Standard and commercial equivalent connectors and accessories.

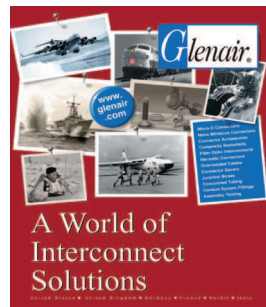

Micro-D Twistpin Connectors and Accessories

Glenair offers both Military Standard 83513 Micro-D connectors as well as COTS selections, backshells, mounting hardware and more. Our TwistPin contact provides superior performance.



EMI/EMP Filter Connectors

MIL-DTL-38999 type EMI/EMP filter connectors, as well as other Military Standard and commercial electromagnetic shielding technologies. Also includes Glenair Series 80 "Mighty Mouse" filter products.



Fiber Optic Interconnect Solutions

Tactical fiber optic connectors, cables, and termini for airframe, shipboard, and military ground vehicles. Catalog features Glenair's innovative high-density (GHD) connector system for reduced size and weight applications.



Available now:
Glenair's
Interconnect Product Guide CD, featuring our entire library of Glenair catalogs and data sheets.



In addition to over a dozen product line catalogs, the CD includes a powerful part number development program that takes all the pain and confusion out of ordering interconnect components. An easy-to-use inventory search program provides ready access to 60,000 MIL-STD and commercial part numbers.

Composite Thermoplastic Interconnect Solutions

Glenair is the world's leading manufacturer of composite interconnect solutions. We are the 'go-to' supplier for advanced composite technologies for commercial and military interconnect applications.

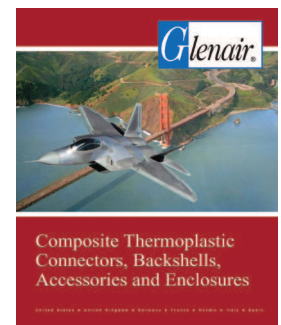

Military Standard Connector Accessories

If the MS connector accessory you need isn't in here – it doesn't exist. Search this easy-to-use catalog by accessory type or Mil-Spec slash number, then place your order against Glenair's 60,000 part number same-day inventory.



Series 80 "Mighty Mouse" Connectors and Cables

Glenair's revolutionary connector series that reduces interconnect system size and weight by 50% compared to standard MIL-DTL-38999 connectors. Now used on hundreds of mission-critical military and commercial applications.

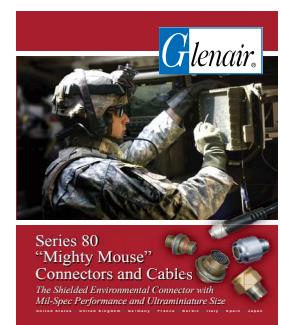

Visit us at www.glenair.com and use the literature order form for immediate catalog fulfillment



A World of Interconnect Solutions

Glenair, Inc.

1211 Air Way • Glendale, California • 91201-2497
Telephone: 818-247-6000 • Fax: 818-500-9912 • sales@glenair.com
www.glenair.com

**Glenair Industrial Power and
Signal Connector Group** Telephone: 203-741-1115
25 Village Lane Facsimile:
Wallingford, CT 203-741-0053
06492 sales@glenair.com

Glenair UK Ltd Telephone: 44-1623-638100
40 Lower Oakham Way Facsimile:
Oakham Business Park 44-1623-638111
P.O. Box 37, Mansfield sales@glenair.co.uk
Notts, NG18 5BY England

Glenair Microway Systems Telephone: 847-679-8833
7000 North Lawndale Avenue Facsimile:
Lincolnwood, IL 847-679-8849
60712

Glenair Nordic AB Telephone: 46-8-50550000
Gustav III : S Boulevard 46 Facsimile:
S - 169 27 Solna 46-8-50550001
Sweden sales@glenair.se

Glenair Electric GmbH Telephone: 49-6171-5905-0
Siemensstrasse 9 Facsimile:
D-61449 Steinbach 49-6171-5905-90
Germany germany@glenair.com

Glenair Iberica Telephone: 34-925-89-29-88
C/ La Vega, 16 Facsimile:
45612 Velada 34-925-89-29-87
Spain sales@glenair.es

Glenair Italia S.p.A. Telephone: +39-051-780098
Via Cà dell'Orbo Nord, 22 Facsimile:
40055 Villanova di Castenaso +39-051-782259
Bologna, Italy info@glenair.it

Glenair France SARL Telephone: 33-5-34-40-97-40
7, Avenue Parmentier Facsimile:
Immeuble Central Parc #2 33-5-61-47-86-10
31200 Toulouse sales@glenair.fr
France

