



600-058 and 600-061
The Band-Master™ ATS Clamping System
Hand Banding Tools

Fast, Cost-Effective Shielding Termination

The Band-Master™ ATS clamping system provides quick, easy, cost-effective and highly reliable termination of braided metallic shielding or fabric braid. Two sizes of banding tools and bands (bands are also available in standard and extended lengths) allow complete flexibility in terminating EMI shielding and protective mechanical braiding to fiber optic and electrical harnesses. Glenair's complete line of Band-Master™ ATS products are in stock and ready for immediate shipment.



Manual Hand Tools

Hand Banding Tool 600-058

The 600-058 Hand Banding Tool weighs 1.18 lbs., and is designed for standard clamping bands 600-052 and 600-090 (see page 36) in a tension range from 100 to 180 lbs. Calibrate at 150 lbs. ± 5 lbs. for most shield terminations. Tool and band should never be lubricated.

Reference: Band-Master™ ATS part number A40199.

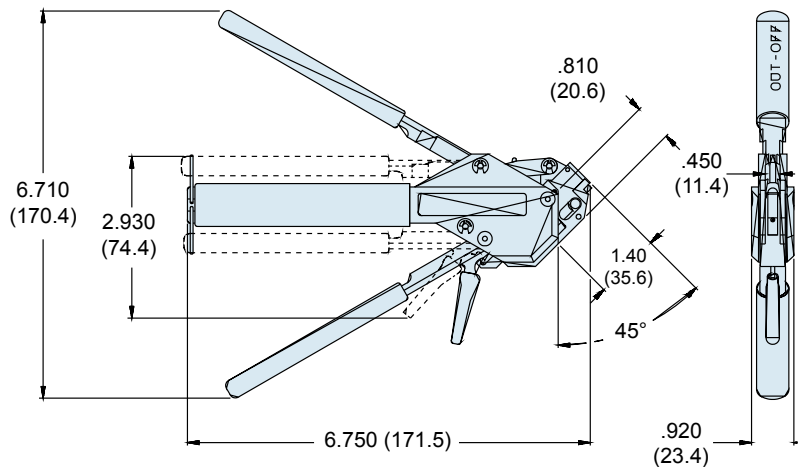

Hand Micro Banding Tool 600-061

The 600-061 Hand Micro Banding Tool weighs 1.18 lbs., and is designed for micro clamping bands 600-057 and 600-083 (see page 36) in a tension range from 50 to 85 lbs. Calibrate at 75lbs +2 lbs. -7 lbs. for most shield terminations. Tool and band should never be lubricated.

Reference: Band-Master™ ATS part number A30199.

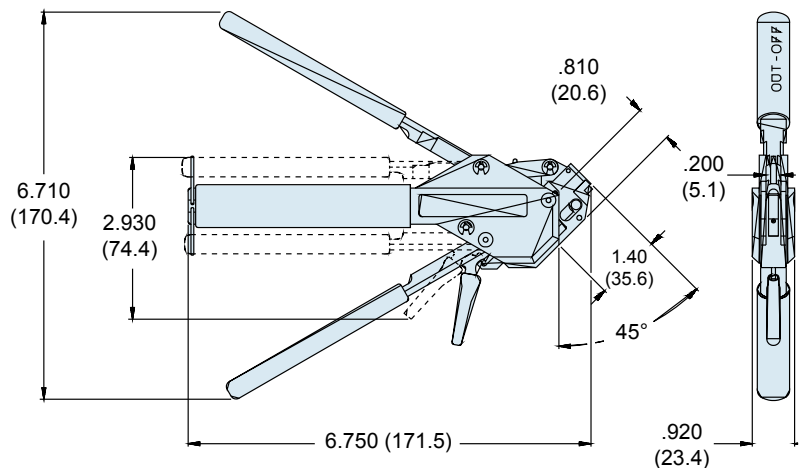

Metric Dimensions (mm) are indicated in parentheses.