



**189-016**  
**Backshell with Banding Strain Relief**  
**Environmental Resistant**  
**for MIL-DTL-38999 Series III Fiber Optic Connectors**

**D38999**  
Series III

**B**

**MIL-DTL-38999 Series III backshell with strain relief**



**How To Order**

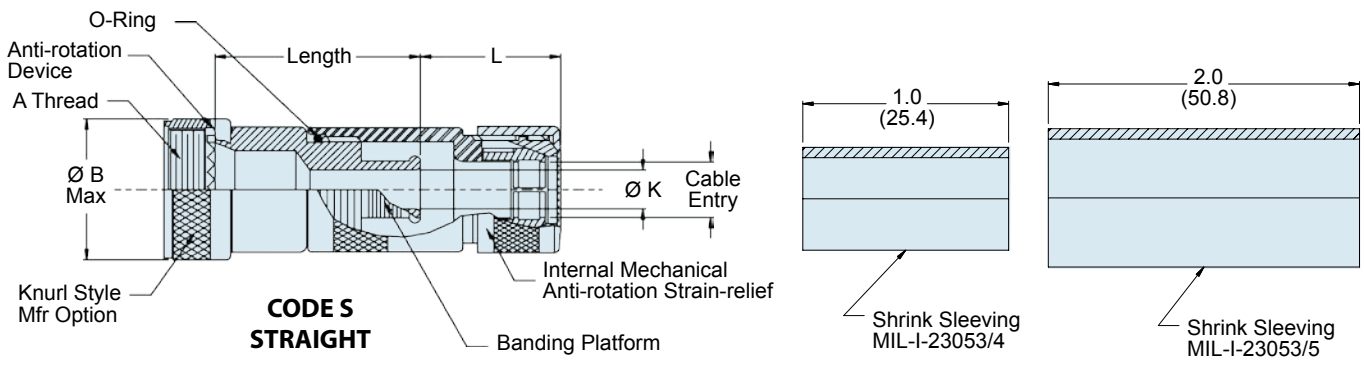
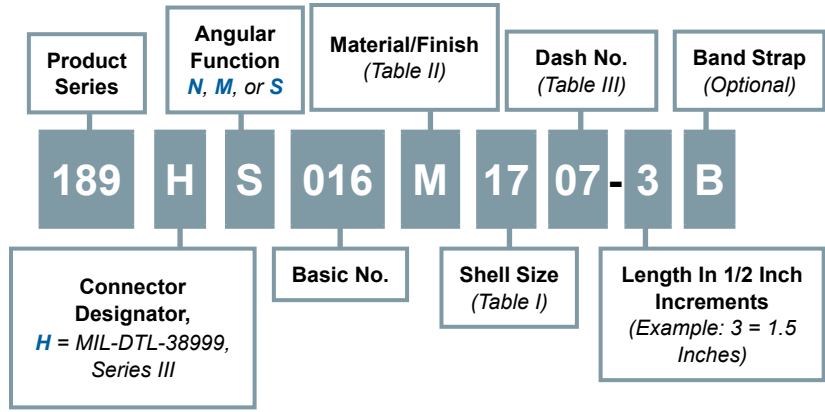

**Material and Finish**

Adapter, Coupling Nut: See Table II  
 Clamp Components: Ryton R4XT-Black, Ultem 1000-Natural  
 Anti-Rotation Device: Torlon 42031-Natural

**Notes**

Glenair 600 Series Backshell assembly tools are recommended for assembly and installation.  
 Standard minimum length: 1.5 inches, for shorter length consult factory.  
 For Shield termination see Glenair drawings 600-050 & 600-052.  
 Consult factory for larger cable size.  
 MIL-I-23053/4 & /5 Shrink Sleeving to be packaged loose in a plastic bag.  
 MIL-I-23053/4 Shrink Sleeving to be heat shrunk over rear of Adapter before MIL-I-23053/5 Shrink Sleeving.

**189-016**  
**Backshell with Banding Strain Relief**  
**Environmental Resistant**  
**for MIL-DTL-38999 Series III Fiber Optic Connectors**



MIL-DTL-38999  
Series III Type

**B**

Table I

Shell Size	A Thread	ØB Max	C Max	D Max	E Max	F Max	Max Dash No.
11	M15 x 1 - 6H	0.890 (22.6)	.861 (21.9)	1.111 (28.2)	1.563 (39.7)	1.875 (47.6)	05
13	M18 x 1 - 6H	1.020 (25.9)	.911 (23.1)	1.161 (29.5)	1.938 (49.2)	2.250 (57.2)	05
15	M22 x 1 - 6H	1.150 (29.2)	.965 (24.5)	1.215 (30.9)	1.938 (49.2)	2.250 (57.2)	07
17	M25 x 1 - 6H	1.230 (31.2)	1.014 (25.8)	1.264 (32.1)	2.063 (52.4)	2.375 (60.3)	07
19	M28 x 1 - 6H	1.360 (34.5)	1.064 (27.0)	1.314 (33.4)	2.063 (52.4)	2.375 (60.3)	09
21	M31 x 1 - 6H	1.480 (37.6)	1.118 (28.4)	1.368 (34.7)	2.563 (65.1)	2.875 (73.0)	11
23	M34 x 1 - 6H	1.600 (40.6)	1.172 (29.8)	1.422 (36.1)	2.313 (58.8)	2.688 (68.3)	11
25	M37 x 1 - 6H	1.730 (43.9)	1.221 (31.0)	1.471 (37.4)	2.250 (57.2)	2.563 (65.1)	13

Table II: Material and Finish

Code	Material	Finish Description
M	Aluminum Alloy	Electroless Nickel
NF		Cadmium Plate, Olive Drab, Over Nickel

Refer to Appendix for material/finish details

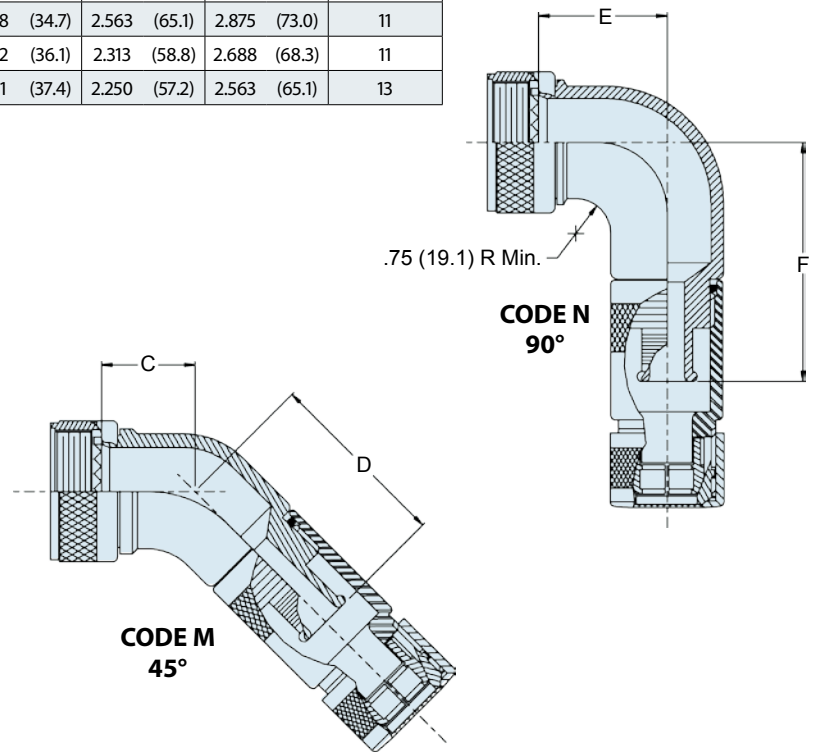

Table III

Dash No.	Clamp Size	Cable Dia Max	Ø K ±005	L Max	MIL-I-23053 Shrink Sleeve	MIL-I-23053 Shrink Sleeve	Cable Entry Dia	
							Min	Max
05	12	.280 (7.11)	.312 (7.92)	1.110 (28.2)	/4-203-0	/5-107-0	.233 (5.92)	.375 (9.53)
07	16	.395 (10.0)	.438 (11.1)	1.210 (30.7)	/4-204-0	/5-108-0	.358 (9.10)	.500 (12.7)
09	20	.510 (13.0)	.562 (14.3)	1.210 (30.7)	/4-204-0	/5-109-0	.482 (12.2)	.625 (15.9)
11	24	.621 (15.8)	.688 (17.5)	1.210 (30.7)	/4-205-0	/5-109-0	.545 (13.8)	.750 (19.1)
13	28	.736 (18.7)	.812 (20.6)	1.360 (34.5)	/4-205-0	/5-110-0	.670 (17.0)	.875 (22.2)
15	32	.851 (21.6)	.938 (23.8)	1.510 (38.4)	/4-206-0	/5-110-0	.795 (20.2)	1.000 (25.4)
17	36	.966 (24.5)	1.062 (27.0)	1.510 (38.4)	/4-206-0	/5-111-0	.889 (22.6)	1.125 (28.6)
19	40	1.091 (27.7)	1.188 (30.2)	1.510 (38.4)	/4-206-0	/5-111-0	1.104 (28.0)	1.250 (31.8)