

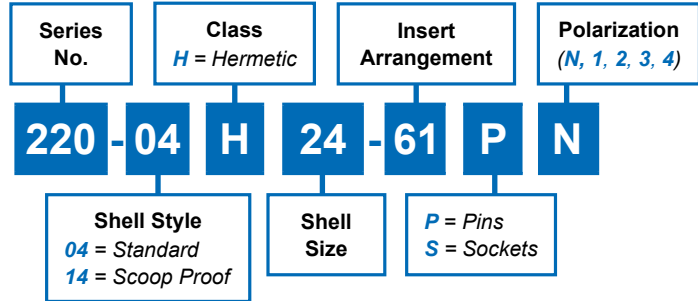

220-04 and 220-14 Rear Wall Mount Jam Nut Receptacle

How To Order



H

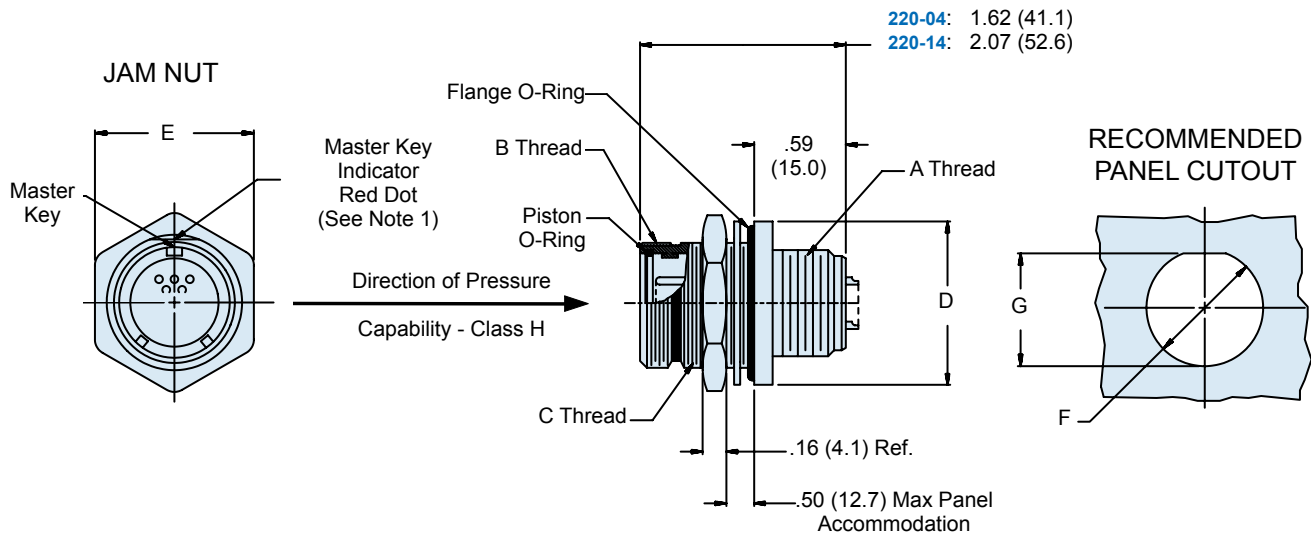

APPLICATION NOTES

1. Flat and master key indicator rotates with master key per position noted on Page A-4.
2. Hermeticity rating: less than 1×10^{-6} cc helium per second.
3. Open face pressure rating: 1000 to 5000 psi

Metric dimensions (mm) are indicated in parentheses

220-04 and 220-14 Rear Wall Mount Jam Nut Receptacle



Dimensions

SHELL SIZE	A THREAD CLASS 2A	B THREAD CLASS 2A	C THREAD CLASS 2A	D DIA	E FLATS	F DIA ±.005±(0.1)	G ±.005±(0.1)
10	5/8 - 24 UNEF	.750 - .1P - .1L	7/8 - 20 UNEF	1.25 (31.8)	1.125 (28.6)	.885 (22.5)	.835 (21.2)
12	3/4 - 20 UNEF	.875 - .1P - .1L	1 - 20 UNEF	1.38 (35.1)	1.250 (31.8)	1.010 (25.7)	.960 (24.4)
14	7/8 - 20 UNEF	1.000 - .1P - .1L	1 1/8 - 16 UN	1.50 (38.1)	1.500 (38.1)	1.135 (28.8)	1.085 (27.6)
16	1 - 20 UNEF	1.125 - .1P - .1L	1 1/4 - 16 UN	1.63 (41.4)	1.625 (41.3)	1.260 (32.0)	1.210 (30.7)
18	1 1/8 - 16 UN	1.250 - .1P - .1L	1 3/8 - 16 UN	1.75 (44.5)	1.750 (44.5)	1.385 (35.2)	1.335 (33.9)
20	1 1/4 - 16 UN	1.375 - .1P - .1L	1 1/2 - 16 UN	1.88 (47.8)	1.875 (47.6)	1.510 (38.4)	1.460 (37.1)
22	1 3/8 - 16 UN	1.500 - .1P - .1L	1 5/8 - 16 UN	2.00 (50.8)	2.000 (50.8)	1.635 (41.5)	1.585 (40.3)
24	1 1/2 - 16 UN	1.625 - .1P - .1L	1 3/4 - 16 UN	2.12 (53.8)	2.125 (54.0)	1.760 (44.7)	1.710 (43.4)

Recommended Jam Nut Installation Torque Values

SHELL SIZE	TORQUE ± 5%	
	INCH-POUNDS	NEWTON-METERS
10	95	10.73
12	110	12.43
14	140	15.82
16	170	19.21
18	195	22.03
20	215	24.29
22	235	26.55
24	260	29.38

Replacement O-Ring Part Numbers *

SHELL SIZE	PISTON O-RING	FLANGE O-RING
10	2-014	2-021
12	2-016	2-023
14	2-018	2-025
16	2-020	2-027
18	2-022	2-029
20	2-024	2-030
22	2-026	2-031
24	2-028	2-032

* Parker O-ring part numbers. Compound N674-70 or equivalent.

Metric dimensions (mm) are indicated in parentheses