

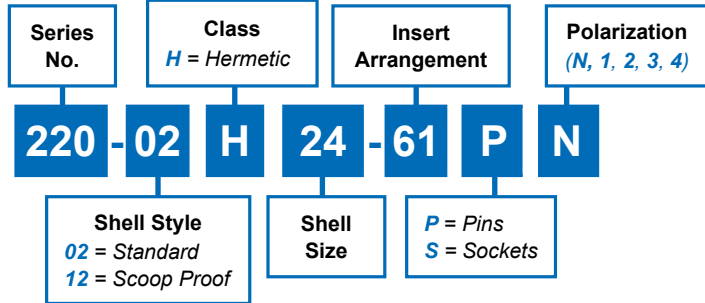

220-02 and 220-12 Square Flange Mount Receptacle

How To Order



H

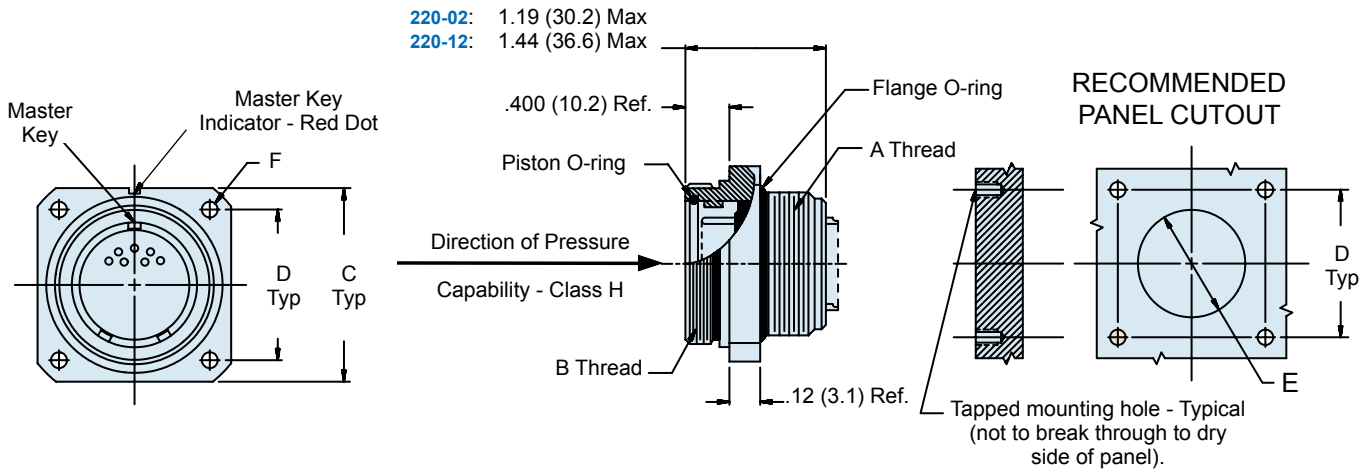

APPLICATION NOTES

1. Prior to use, lubricate O-rings with high grade silicone lubricant (Moly-kote M55 or equivalent).
2. Hermeticity rating: less than 1×10^{-6} cc helium per second.
3. Open face pressure rating: 1000 to 5000 psi

Metric dimensions (mm) are indicated in parentheses

220-02 and 220-12 Square Flange Mount Receptacle



Dimensions					
SHELLSIZE	A THREAD CLASS 2A	B THREAD CLASS 2A	C DIM	D DIM	E DIA + .015 + (0.4) - .000 - (0.0)
10	5/8 - 24 UNEF	.750 - .1P - .1L	1.188 (30.2)	.938 (23.8)	.844 (21.4)
12	3/4 - 20 UNEF	.875 - .1P - .1L	1.312 (33.3)	1.062 (27.0)	.969 (24.6)
14	7/8 - 20 UNEF	1.000 - .1P - .1L	1.438 (36.5)	1.188 (30.2)	1.078 (27.4)
16	1 - 20 UNEF	1.125 - .1P - .1L	1.562 (39.7)	1.250 (31.8)	1.219 (31.0)
18	1 1/8 - 16 UN	1.250 - .1P - .1L	1.750 (44.5)	1.375 (34.9)	1.359 (34.5)
20	1 1/4 - 16 UN	1.375 - .1P - .1L	1.875 (47.6)	1.500 (38.1)	1.515 (38.5)
22	1 3/8 - 16 UN	1.500 - .1P - .1L	2.000 (50.8)	1.625 (41.3)	1.640 (41.7)
24	1 1/2 - 6 UN	1.625 - .1P - .1L	2.125 (54.0)	1.750 (44.5)	1.765 (44.8)

Mounting/Hardware Information		
SHELL SIZE	F DIA	MTG SCREW REF.
10	.125 (3.2)	No. 4
12	.125 (3.2)	No. 4
14	.125 (3.2)	No. 4
16	.125 (3.2)	No. 4
18	.125 (3.2)	No. 4
20	.125 (3.2)	No. 4
22	.125 (3.2)	No. 4
24	.156 (4.0)	No. 6

Replacement O-Ring Part Numbers		
SHELL SIZE	PISTON O-RING	FLANGE O-RING
10	2-014	2-021
12	2-016	2-023
14	2-018	2-025
16	2-020	2-027
18	2-022	2-029
20	2-024	2-030
22	2-026	2-031
24	2-028	2-032

*Parker o-ring part numbers. Compound N674-70 or equivalent.

Metric dimensions (mm) are indicated in parentheses