

MIL-DTL-83723/89 Series III Type Hermetic Threaded Coupling Jam-Nut Mount Receptacle with Solder Cup Terminations

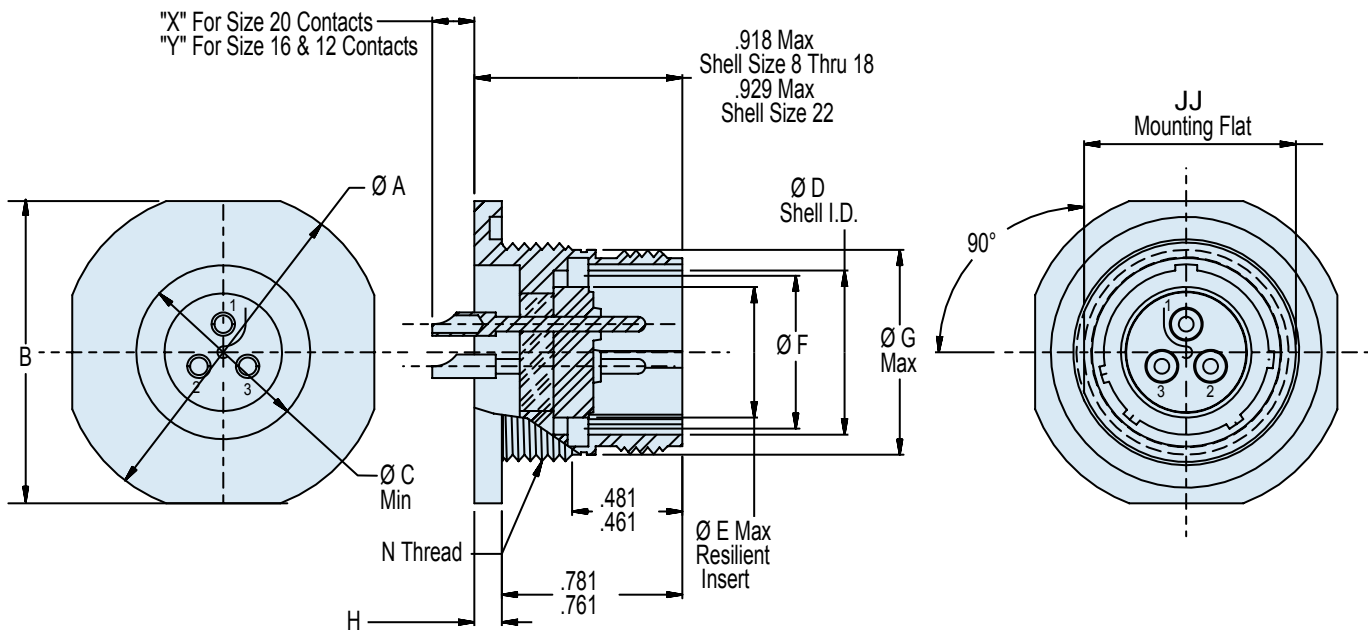
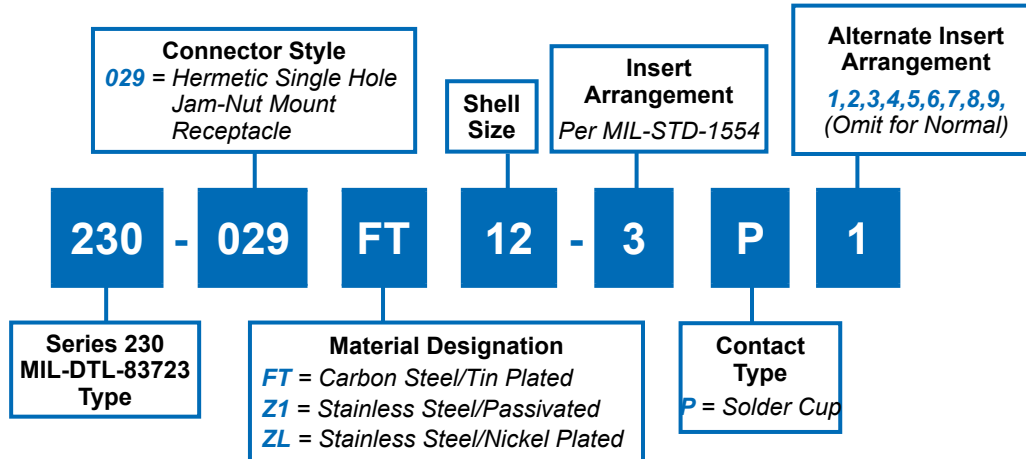

APPLICATION NOTES

- To be identified with manufacturer's name, part number and date code, space permitting.
- Material/Finish:
Shell* and Jam-Nut:
Z1 - Stainless steel/passivated.
FT - Carbon steel/tin plated.
ZL - Stainless steel/nickel plated.
Contacts - 52 Nickel alloy/gold plated.
Seals - Silicone elastomer/N.A.
Insulation - Glass/N.A.
- Glenair 230-029 will mate with any QPL MIL-DTL-83723/86, /91, /95 and /97 Series III bayonet coupling plug of same size, keyway, and insert polarization.
- Performance:
Hermeticity <math>< 1 \times 10^{-7}</math> cc He/sec @ 1 atmosphere differential.
Dielectric withstanding voltage - Consult factory or MIL-STD-1554.
Insulation resistance - 5000 MegOhms min @ 500VDC.
- Consult factory and/or MIL-STD-1554 for arrangement, keyway, and insert position options.
- Metric Dimensions (mm) are indicated in parentheses.

* Additional shell materials available, including titanium and Inconel®. Consult factory for ordering information.

230-029

MIL-DTL-83723/89 Series III Type Hermetic
Threaded Coupling Jam-Nut Mount Receptacle
with Solder Cup Terminations



MIL-DTL-83723
Type

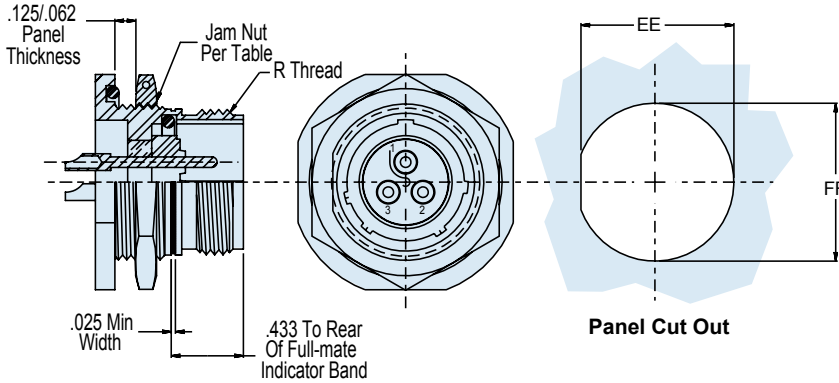

HERMETIC LEAK RATE MOD CODES	
Designator	Required Leak Rate
-585A	1 x 10 ⁻¹⁰ cc Helium per second
-585B	1 x 10 ⁻⁹ cc Helium per second
-585C	1 x 10 ⁻⁸ cc Helium per second

E

TABLE I: CONNECTOR AND CUT-OUT DIMENSIONS (Continued Below)								
Shell Size	A Dia Max	B	C Dia Min	D Dia Shell I.D.	E Dia Resilient Insert	F Dia Max Seal	G Dia Max	H Flange Thickness
8	1.078/1.047 (27.4/26.6)	.980/.949 (24.9/24.1)	.400 (10.2)	.418/.413 (10.6/10.5)	.290 (7.4)	.394 (10.0)	.562 (14.3)	.137/.097 (3.5/2.5)
10	1.192/1.162 (30.3/29.5)	1.104/1.073 (28.0/27.3)	.411 (10.4)	.535/.530 (13.6/13.5)	.388 (9.9)	.515 (13.1)	.696 (17.7)	.137/.097 (3.5/2.5)
12	1.380/1.349 (35.1/34.3)	1.291/1.260 (32.8/32.0)	.581 (14.8)	.705/.700 (17.9/17.8)	.558 (14.2)	.685 (17.4)	.875 (22.2)	.137/.097 (3.5/2.5)
14	1.516/1.485 (38.5/37.7)	1.391/1.360 (35.3/34.5)	.650 (16.5)	.774/.769 (19.7/19.5)	.627 (15.9)	.754 (19.2)	.936 (23.9)	.137/.097 (3.5/2.5)
16	1.641/1.610 (41.7/40.9)	1.516/1.485 (38.5/37.7)	.777 (19.7)	.901/.896 (22.9/22.8)	.772 (19.6)	.881 (22.4)	1.062 (27.0)	.137/.097 (3.5/2.5)
18	1.766/1.735 (44.9/44.1)	1.641/1.610 (41.7/40.9)	.864 (21.9)	1.007/1.002 (25.6/25.5)	.860 (21.8)	.987 (25.1)	1.187 (30.1)	.137/.097 (3.5/2.5)
22	2.078/2.047 (52.8/52.0)	1.954/1.923 (49.6/48.8)	1.133 (28.8)	1.257/1.252 (31.9/31.8)	1.110 (28.2)	1.237 (31.4)	1.437 (36.5)	.148/.128 (3.8/3.3)

TABLE I: CONNECTOR AND CUT-OUT DIMENSIONS (Continued From Above)								
Shell Size	N Thread	R Thread	JJ Mounting Flat	Panel Cut-Out EE +.000 -.002 (.05)	Panel Cut-Out FF DIA ±.005 (0.1)	Jam Nut MS3186	X	Y
8	.625-20 UN-2A	.562-24 UNEF-2A	.596/.590 (15.1/15.0)	.605 (15.4)	.635 (16.1)	-105	.180/.120 (4.6/3.0)	.210/.150 (5.3/3.8)
10	.750-20 UNEF-2A	.688-24 UNEF-2A	.721/.715 (18.3/18.2)	.730 (18.5)	.760 (19.3)	-107	.180/.120 (4.6/3.0)	.210/.150 (5.3/3.8)
12	.937-20 UNEF-2A	.875-20 UNEF-2A	.908/.902 (23.1/22.9)	.917 (23.3)	.947 (24.1)	-110	.180/.120 (4.6/3.0)	.210/.150 (5.3/3.8)
14	1.000-20 UNEF-2A	.938-20 UNEF-2A	.971/.965 (24.7/24.5)	.980 (24.9)	1.010 (25.7)	-111	.180/.120 (4.6/3.0)	.210/.150 (5.3/3.8)
16	1.125-20 UNEF-2A	1.062-18 UNEF-2A	1.096/1.090 (27.8/27.7)	1.105 (28.1)	1.135 (32.1)	-112	.180/.120 (4.6/3.0)	.210/.150 (5.3/3.8)
18	1.250-18 UNEF-2A	1.188-18 UNEF-2A	1.220/1.214 (31.0/30.8)	1.230 (31.2)	1.260 (32.0)	-116	.180/.120 (4.6/3.0)	.210/.150 (5.3/3.8)
22	1.500-18 UNEF-2A	1.438-18 UNEF-2A	1.470/1.464 (37.3/37.2)	1.480 (37.6)	1.510 (38.4)	-120	.169/.109 (4.3/2.8)	.199/.139 (5.1/3.5)