

DAVICOM Semiconductor, Inc.

DM5886

960H and 720H Decoder Mix 4 NTSC/PAL
channels to a SD or HD signal

DATA SHEET

Preliminary
Version: DM5886-DS-P01
February 27, 2013



REVISION HISTORY:

Date	Revision	Description
2012/02/02	1.1	Initial release
2012/02/04	1.2	Application schematics modified

PRELIMINARY

Table of Contents

INTRODUCTION	6
FEATURES.....	7
APPLICATIONS	8
TERMINAL ASSIGNMENT	9
TERMINAL FUNCTIONS	10
BLOCK DIAGRAM	15
VIDEO DECODER	16
VIDEO INTERFACE.....	16
Multi-channel Time Division Multiplexing	17
4-CH VIDEO DECODER.....	19
VIDEO DECODER UNIT.....	20
Video Synchronization	20
Automatic Gain Control	20
Y/C Separation.....	20
UV demodulation.....	21
Luma/Chroma Processor.....	21
Video Interface.....	21
Fast Switch Parameter RAM.....	21
FILTER RESPONSE	22
Anti-alias LPF (960H).....	22
Decimation filter (960H)	22
Luma notch filter (960H).....	23
Chroma band pass filter (960H).....	23
Y sharpness filter (960H).....	24
UV demodulation low pass filter (960H).....	25



Anti-alias LPF (720H).....	25
Decimation filter (720H)	26
Luma notch filter (720H).....	26
Chroma band pass filter (720H).....	27
Y sharpness filter (720H).....	27
UV demodulation low pass filter (720H).....	28
AUDIO CODEC.....	29
DIGITAL AUDIO FORMAT.....	31
EXTENDED DIGITAL AUDIO FORMAT	32
CASCADE MODE FOR MULTI-CHIP OPERATION	33
PLL	35
HOST INTERFACE.....	36
VIDEO MIXER.....	37
OUTPUT FORMAT	38
VIDEO MIXER BLOCK.....	39
Video Source	39
Channel Switch Block.....	39
Capture interface.....	40
Mixer Core.....	45
Mix-Out Interface	45
Chip-Level Output Unit	50
GENERAL PURPOSE INPUT /OUTPUT (GPIO).....	52
GPO	52
GPI.....	53
INTERNAL CONTROL REGISTERS.....	55
SYSTEM CONTROL	55



DM5886

960H and 720H Decoder Mix 4 NTSC/PAL channels to a SD or HD signal

VIDEO ADC	70
PLL.....	77
AUDIO ADC/DAC.....	82
VIDEO DECODER	92
AGC	93
Video Detection Misc.....	94
Color Killer.....	95
2D Comb Filter.....	95
VIDEO MIXER.....	119
MIXER OUTSEL CONFIGURATION TABLE.....	142
ELECTRICAL SPECIFICATIONS	147
ABSOLUTE MAXIMUM RATINGS OVER OPERATING FREE-AIR TEMPERATURE RANGE.....	147
Recommended Operating Conditions	148
Crystal Specifications	149
ELECTRICAL CHARACTERISTICS	149
DC ELECTRICAL CHARACTERISTICS.....	149
Analog Processing and A/D Converters	150
Timing	151
PACKAGING.....	154
ORDERING INFORMATION.....	155
DISCLAIMER.....	155
PRODUCTS	155
CONTACT WINDOWS.....	155

Introduction

The DM5886 is a high-end 4-channel video decoder designed for cameras with Sony's new 960H CCD sensor. The DM5886 converts 4 channels of 9/6.5 MHz analog CVBS signals to 4 channels of digital 36/27 MHz CCIR656 signals. The DM5886 integrates two internal PLLs, and decodes both 960H and 720H videos using the same (27MHz) external clock source. The DM5886 also features a patented fast switch function. With the fast switch function, the DM5886 can decode up to 8 analog CVBS with little frame rate loss.

The DM5886 includes two SD mixers and one HD mixer. Each SD/HD mixer can multiplex up to 4 video sources. In addition to two SD CCIR656 outputs or one HD SMPTE 274M output, the DM5886 mixer can output four D1 videos through one TDM4 interface. The mixers support image mirror and H partition functions. Both interlaced and progressive digital video outputs are supported.

The DM5886 also includes five audio ADCs and one audio DAC. Audio cascade up to 16 channels is also supported.

Features

Video Decoder

- Accepts NTSC (M), PAL (B, D, G, H, I, M, Nc) and SONY 960H CCD Camera
- Each 2 of the 4 video decoders could be programmed to operate at 27 or 36MHz.
- Hardware Fast Switch function
- Fast Switch also controllable by software or external pin
- Software channel ID in active region
- Four 10-bits video ADCs with built in 9/6.5 MHz analog low pass filter
- Automatic gain control for Luminance and Chrominance
- Programmable brightness, contrast, saturation, hue, and sharpness
- 5-H comb filter for YC separation
- Chrominance line filter for PAL phase error
- DLL for video synchronization, supports 27MHz crystal within +/-1000 ppm variance
- Advanced video synchronization for weak and noisy CVBS. Supports video signal transmitted by 500-meter long cable
- Up to 3 CCIR656 output interfaces which could be configured as 3 sets of CCIR656 (36/27MHz) or 3 sets of TDM2 (72/54MHz) or 3 set of TDM4 (144/108MHz)
- Support line lock camera

Audio Codecs

- Five audio ADCs and one audio DAC are integrated
- Master I2S/DSP playback, record and audio-mixing
- Supports extended I2S/DSP format transmitting up to 16 audio channels using one data pin
- Audio cascade up to 16 channels
- 16-bit or 8-bit 48/24/16/8 KHz PCM format

Video Mixer

- Two SD mixers and one HD mixer. Each mixer supports up to 4 channels
- Two SD CCIR656 outputs (36/27MHz) or one HD SMPTE 274M output (74.25MHz)
- One TDM4 (144/108MHz) output
- One optional TDM4 input as mixer video sources.
- Various mixing combinations. Special H partition supported
- Video mirror supported
- Support both interlaced and progressive mixer output
- 16-bit SDRAM interface

Miscellaneous

- Use a single external 27MHz crystal to support both 960H and 720H video
- Two programmable PLLs integrated
- Slave I2C bus
- Ultra low power consumption. Under 500mW for normal operation. Under 50mW for suspend mode.
- 128-pin LQFP package (14mmx14mm)
- 1.8V core power, 3.3V analog power and 1.8V analog power

Applications

Suggested applications include

- DVR
- Car DVR
- Video capture card

Terminal Assignment

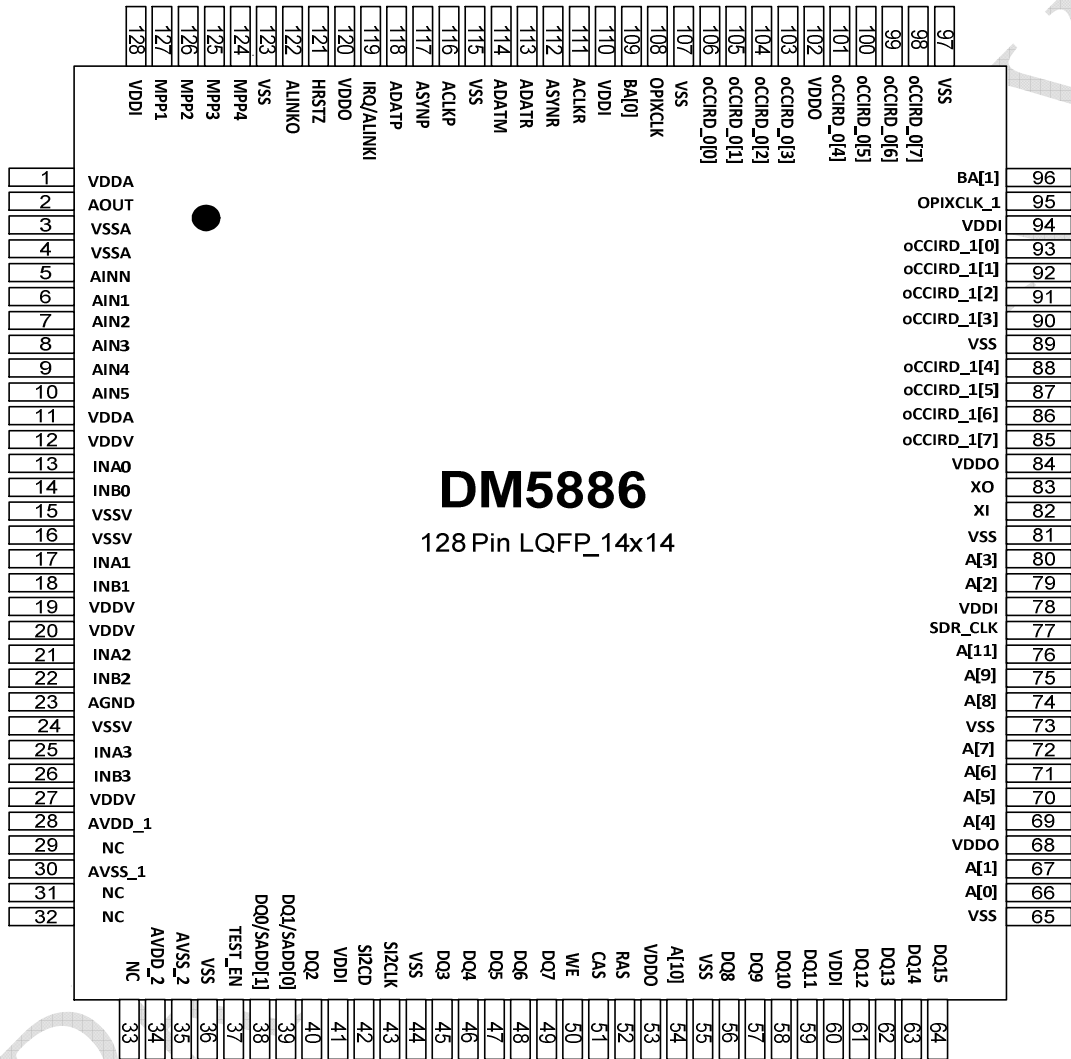

Terminal Functions
Analog Video/Audio Interface Pins

Pin Name	Pin number	Type	Description
INA0	13	A	CVBS input A of channel 0 or S-VIDEO Y of channel 0
INB0	14	A	CVBS input B of channel 0 or S-VIDEO Y of channel 0
INA1	17	A	CVBS input A of channel 1 or S-VIDEO C of channel 0
INB1	18	A	CVBS input B of channel 1 or S-VIDEO C of channel 0
INA2	21	A	CVBS input A of channel 2 or S-VIDEO Y of channel 1
INB2	22	A	CVBS input B of channel 2 or S-VIDEO Y of channel 1
INA3	25	A	CVBS input A of channel 3 or S-VIDEO C of channel 1
INB3	26	A	CVBS input B of channel 3 or S-VIDEO C of channel 1
AIN1	6	A	Audio input of channel 1
AIN2	7	A	Audio input of channel 2
AIN3	8	A	Audio input of channel 3
AIN4	9	A	Audio input of channel 4
AIN5	10	A	Audio input of channel 5
AINN	5	A	Audio input negative control
AOUT	2	A	Audio output

Digital Video/Audio Interface Pins

Pin Name	Pin number	Type	Description
oCCIRD_0[7:0]	98,99,100, 101,103,104 105,106	O	Video data output of channel 0 or SMPTE 274M Y bus output or TDM2/TDM4 Output Data Bus
oCCIRD_1[7:0]	85,86,87, 88,90,91, 92,93	O	Video data output of channel 1 or SMPTE 274M C bus output or TDM2/TDM4 Output Data Bus
A[11:0]	76,54,75,74, 72,71,70,69, 80,79,67,66	IO	SDRAM ADDRESS Bus
DQ[15:2]	64,63,62,61, 59,58,57,56, 49,48,47,46, 45,40,	IO	SDRAM DATA Bus
DQ0/SADD[1]	38	I	SDRAM DATA Bus DQ[0], MSB of I2C Device ID strapping
DQ1/SADD[0]	39	I	SDRAM DATA Bus DQ[1], LSB of I2C Device ID strapping
SDR_CLK	77	O	SDRAM CLOCK
BA[1:0]	96,109	IO	SDRAM BANK Select
WE	50	O	SDRAM Control : WE
CAS	51	O	SDRAM Control : CAS
RAS	52	O	SDRAM Control : RAS
ACLKR	111	O	Audio serial clock output of record
ASYNR	112	O	Audio serial sync output of record.
ADATR	113	O	Audio serial data output of record
ADATM	114	O	Audio serial data output of mixing
ACLKP	116	IO	Audio serial clock output of playback or TDM2/TDM4 Input/output Data Bus[7]
ASYNP	117	IO	Audio serial sync output of playback or TDM2/TDM4 Input/output Data Bus[6]
ADATP	118	IO	Audio serial data input of playback or TDM2/TDM4 Input/output Data Bus[5]
IRQ/ALINKI	119	IO	Interrupt request output, Audio Multi-chip serial input or TDM2/TDM4 Input/output Data Bus[4]
ALINKO	122	IO	Audio Multi-chip serial output or TDM2/TDM4 Input/output Data Bus[3]

GPIO

Pin Name	Pin number	Type	Description
MPP4	124	IO	FLD/ACTIVE/NOVID/FASTSW_SEL of channel 4 or TDM2/TDM4 Input/output Data Bus[2]
MPP3	125	IO	FLD/ACTIVE/NOVID/FASTSW_SEL of channel 3 or TDM2/TDM4 Input/output Data Bus[1]
MPP2	126	IO	FLD/ACTIVE/NOVID/FASTSW_SEL of channel 2 or TDM2/TDM4 Input/output Clock
MPP1	127	IO	FLD/ACTIVE/NOVID/FASTSW_SEL of channel 1 or TDM2/TDM4 Input/output Data Bus[0]

System Control Pins

Pin Name	Pin number	Type	Description
HRSTZ	121	I	System reset
XI	82	I	Crystal 27MHz connection or Oscillator clock input.
XO	83	O	Crystal 27MHz connection
OPIXCLK	108	O	36/72/144MHz or SMPTE 274M 74.25MHz clock output.
OPIXCLK_1	95	O	36/72/144MHz clock output
TEST_EN	37	I	Test enable, please connect it to ground
SI2CD	42	IO	Slave I2C data
SI2CLK	43	I	Slave I2C clock

Power, Ground and NC Pins

Pin Name	Pin number	Type	Description
VDDA	1,11	P	1.8V Power for analog audio DAC
VSSA	3,4	G	Ground for analog audio DAC
VDDV	12,19,20,27	P	1.8V Power for video ADC
VSSV	15,16,24	G	Ground for video ADC
AGND	23	G	Analog ground (used as signal input reference, CH_AGND)
AVDD_1	28	P	1.8V Power for analog clock PLL1
AVSS_1	30	G	Ground for analog clock PLL1
AVDD_2	34	P	1.8V Power for analog clock PLL2
AVSS_2	35	G	Ground for analog clock PLL2
VDDI	41,60,78,94, 110,128	P	1.8V Power for internal logic
VDDO	53,68,84, 102,120	P	3.3V Power for output driver
VSS	36,44,55,65, 73,81,89,97, 107,115,123	G	Ground for internal logic and output driver
NC	29,31,32,33		Not Connected

Pin Usage of ITDM Video Input

ITDM Video In	Settings	CCIRINPINOPT=1
	Clock	MI2CD1 (pin 126)
	Data Bus [7:0]	Pin no. {116, 117, 118, 119, 122, 124, 125, 127}

Pin Usage of Video Output

Video Out	1	oCCIRD_0[7:0] SD: CCIR656/TDM2/TDM4 HD: Y component
	2	oCCIRD_1[7:0] SD: CCIR656/TDM2/TDM4 HD: C component
	3	(a) Only when ITDM is disabled (b) set CCIROPINOPT=1 (c) supporting SD: CCIR656/TDM2/TDM4 Data Bus[7:0]: Pin no. {116, 117, 118, 119, 122, 124, 125, 127}

Block Diagram

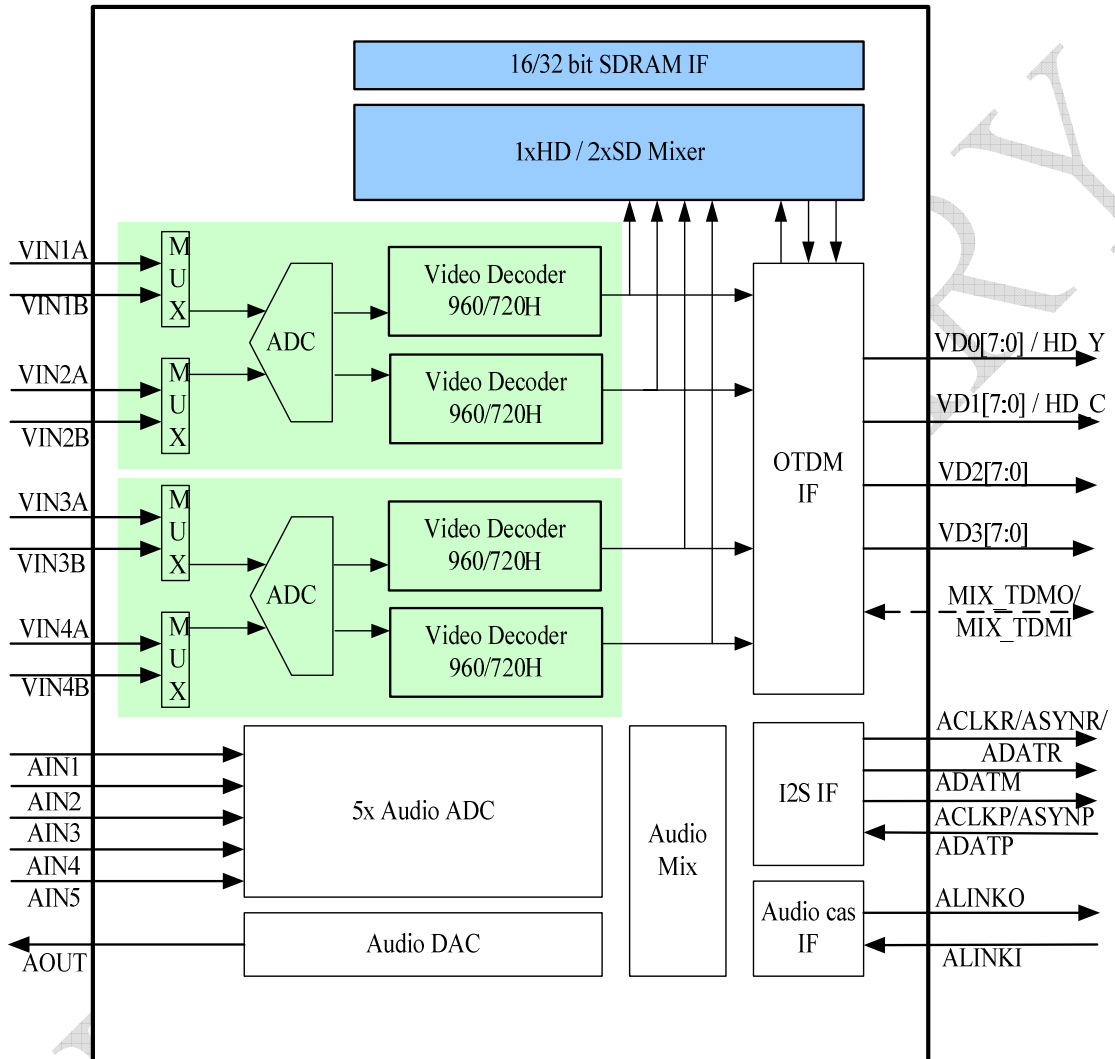

Video Decoder

Video Interface

The DM5886 outputs 27MHz CCIR656 with 720x480/720x576 resolution (conventional 720H), or outputs 36MHz CCIR656-like format (BT.1302) with 960x480/960x576 resolution (Sony 960H).

For these video outputs, SAV (Start of Active Video) and EAV (End of Active Video) are inserted to indicate active video interval. Each channel uses one output port to transmit video data, that is, luminance and chrominance data are transmitted through the same port. The output timing diagram is shown below.

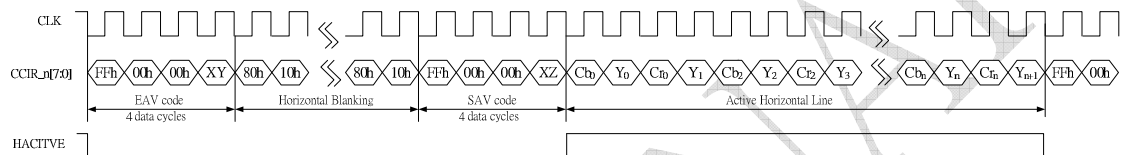

The number of data cycles in active horizontal line will vary according to the output format. For 720H video outputs, the active horizontal line contains 1440 cycles. For 960 H video outputs, the active horizontal line contains 1920 cycles.

SAV and EAV indicate the active video interval. The values of the first three bytes in SAV and EAV are invariant preamble: 0xFF, 0x00, and 0x00. Different values are designated to the last byte according to different conditions: Field, V time, and H time. The MSB of this byte is always set to 1 and it's followed by three bits to represent the condition of F, V, and H respectively. The last four bits are used as protection bits. The detailed code sequences of SAV and EAV are illustrated in the following table.

Condition			FVH Value			SAV/EAV Code Sequence			
Field	V time	H time	F	V	H	Byte 0	Byte 1	Byte 2	Byte 3
Odd	Active	SAV	0	0	0	0xFF	0x00	0x00	0x80
Odd	Active	EAV	0	0	1	0xFF	0x00	0x00	0x9D
Odd	Blank	SAV	0	1	0	0xFF	0x00	0x00	0xAB
Odd	Blank	EAV	0	1	1	0xFF	0x00	0x00	0xB6
Even	Active	SAV	1	0	0	0xFF	0x00	0x00	0xC7
Even	Active	EAV	1	0	1	0xFF	0x00	0x00	0xDA
Even	Blank	SAV	1	1	0	0xFF	0x00	0x00	0xEC
Even	Blank	EAV	1	1	1	0xFF	0x00	0x00	0xF1

Multi-channel Time Division Multiplexing

The DM5886 supports 2/4-channel time division multiplexed output format. Thus two or four video channels can be transmitted through one output port. The clock rate should be two or four times of the original sampling rate according to the number of channels to be multiplexed.

The basic case is the non-multiplexed output. The clock rate follows the original data rate (27 MHz for 720H video, 36 MHz for 960H video). The timing diagram is illustrated below.

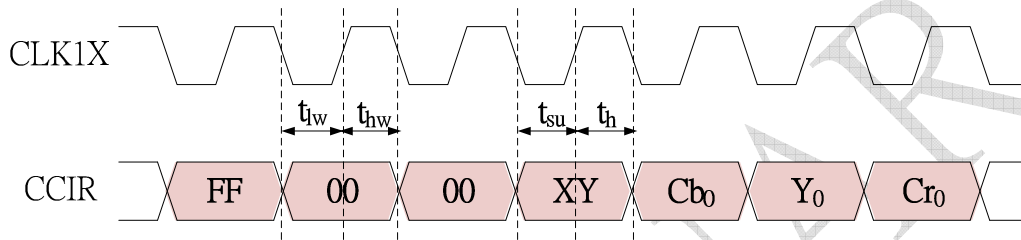

When two-channel multiplexing is selected, two times of the original clock rate is used (54 MHz for 720H video, 72 MHz for 960H video). The timing diagram is illustrated below.

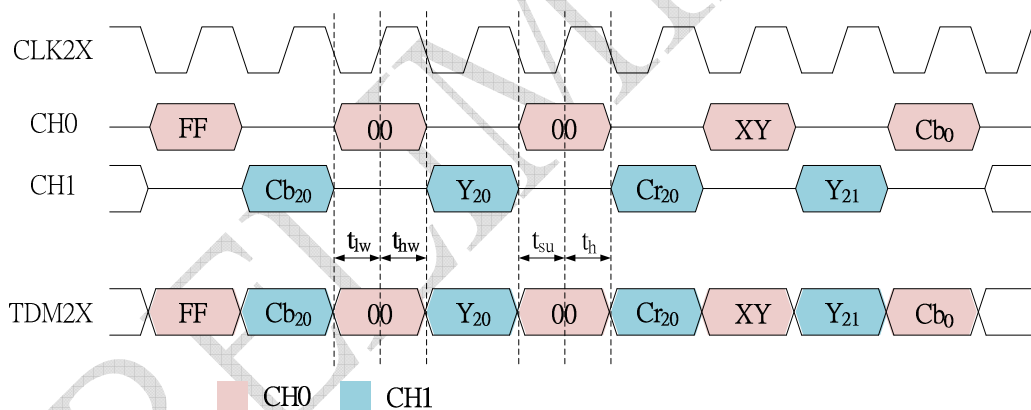

When four-channel multiplexing is selected, four times of the original clock rate is used (108 MHz for 720H video, 144 MHz for 960H video). The timing diagram is illustrated below.

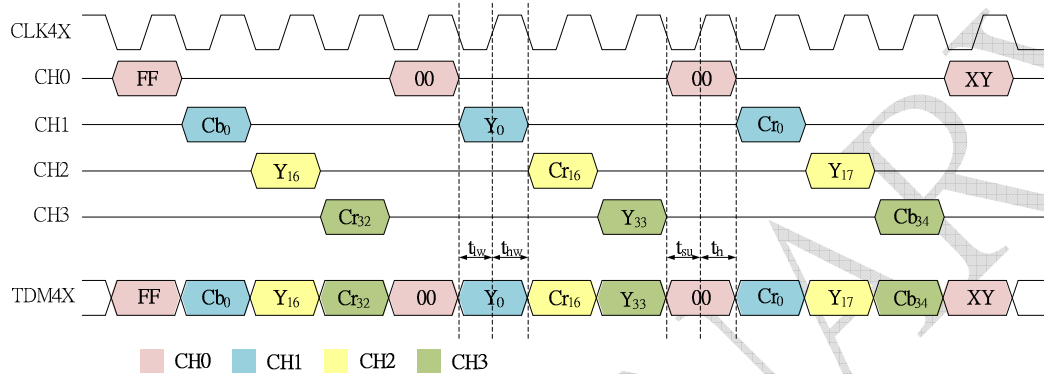

In the Multi-channel Time Division Multiplexing mode, channel IDs are used to indicate the corresponding channels. Channel IDs are defined as the last four bits in SAV/EAV code sequence (i.e. the originally-defined protection bits). The relationship between SAV/EAV code sequence and channel ID is illustrated in the following table.

Condition			FVH Value			EAV/SAV Code Sequence						
Field	V time	H time	F	V	H	Byte 0	Byte 1	Byte 2	Byte 3			
									Ch0	Ch1	Ch2	Ch3
Odd	Active	SAV	0	0	0	0xFF	0x00	0x00	0x80	0x81	0x82	0x83
Odd	Active	EAV	0	0	1	0xFF	0x00	0x00	0x90	0x91	0x92	0x93
Odd	Blank	SAV	0	1	0	0xFF	0x00	0x00	0xA0	0xA1	0xA2	0xA3
Odd	Blank	EAV	0	1	1	0xFF	0x00	0x00	0xB0	0xB1	0xB2	0xB3
Even	Active	SAV	1	0	0	0xFF	0x00	0x00	0xC0	0xC1	0xC2	0xC3
Even	Active	EAV	1	0	1	0xFF	0x00	0x00	0xD0	0xD1	0xD2	0xD3
Even	Blank	SAV	1	1	0	0xFF	0x00	0x00	0xE0	0xE1	0xE2	0xE3
Even	Blank	EAV	1	1	1	0xFF	0x00	0x00	0xF0	0xF1	0xF2	0xF3

4-CH Video Decoder

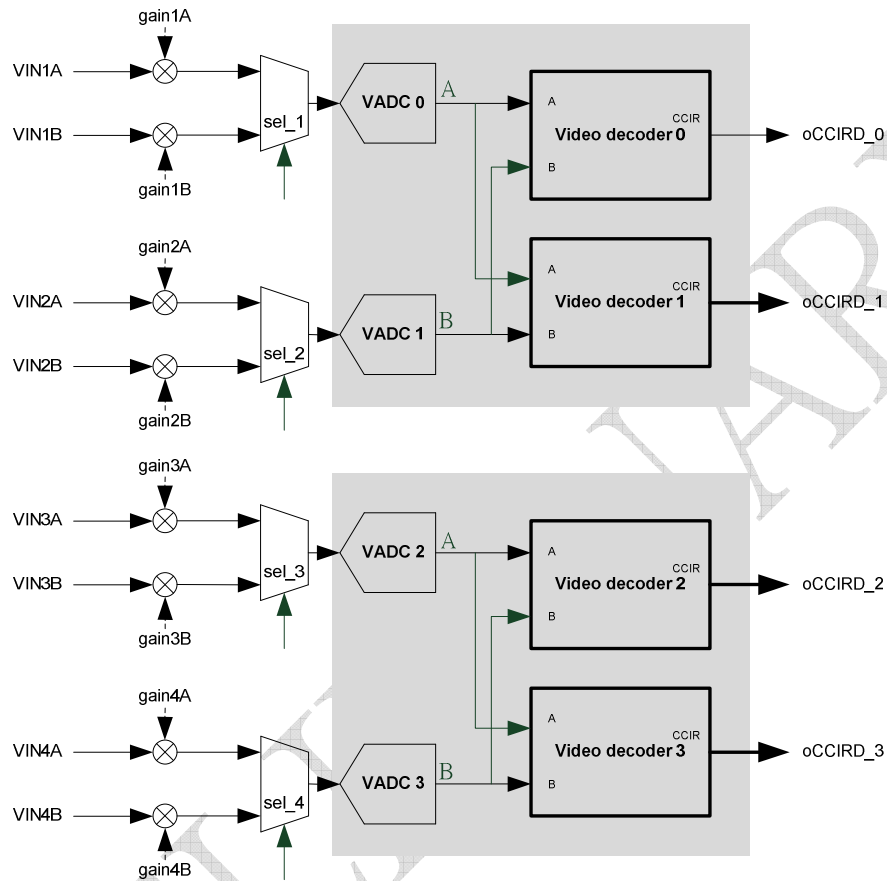

The DM5886 contains four 960H/720H video decoders supporting up to 8 CVBS inputs.

Each CVBS has its own gain amplifier. For each pair of VINA and VINB, a 2-to-1 MUX selects one CVBS source and passes this source to one video analog-to-digital converter (VADC). The DM5886 has 4 VADCs and 4 video decoders (VD). The VADCs and VDs are organized as 2 banks as shown in the above figure. Each bank can be independently configured to operate at 27MHz (for 720H) or 36MHz (for 960H).

Video Decoder Unit

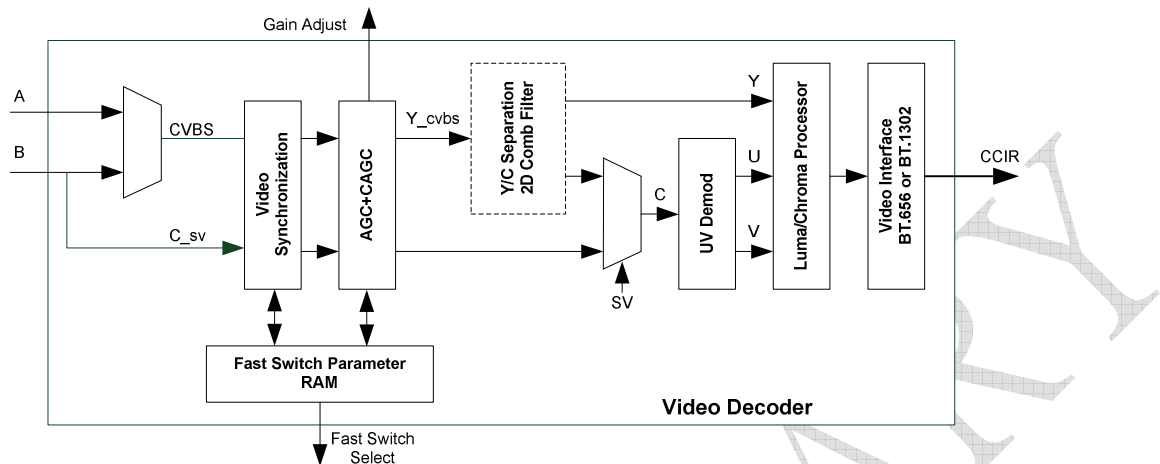

The DM5886 video decoder contains a Video Synchronization block, an AGC block, an YC separation block, a UV Demodulation block, a Luma/Chroma Processor block and a BT 656 output block. A patented Fast Switch is also included.

In addition to CVBS, the DM5886 video decoder supports S-Video as well.

Video Synchronization

Video Synchronization performs video detection function. It automatically detects NTSC(M), NTSC(443), PAL(B,D,G,H,I), PAL(M), PAL(N), PAL(60). A smart video detection algorithm has been adopted. Therefore the DM5886 can perform fast and stable video synchronization even if the input signal is weak or the external crystal is with error as large as +/- 1000 ppm.

Automatic Gain Control

Automatic Gain Control (AGC) block performs both Luma AGC and Chroma AGC (CGAC). After video synchronization, Luma AGC adjusts input Luma level to the standard level (1Vpp). A further CAGC is performed after Luma AGC for signal with different Luma and Chroma attenuation.

Y/C Separation

Y/C Separation is for CVBS input only. After this block CVBS signal is separated into Luma and Chroma components. A 5-H 2D comb filter is adapted in the Y/C separation block.

UV demodulation

After Y/C separation, the UV demodulation block performs UV demodulation to the Chroma component. The phase and frequency of the UV demodulation is from a color burst subcarrier tracking block for both NTSC and PAL mode. A UV demodulation LPF is also adopted to filter out chroma noise.

Luma/Chroma Processor

This block contains a programmable Luma sharpness filter. Hue, Saturation, Brightness and Contrast adjustment are also supported. The adjusted video is then transformed from YUV to YCbCr domain for CCIR656 output interface.

Video Interface

The DM5886 video decoder supports 27MHz BT.656 (for 720H) and 36MHz BT.656-like (for 960H) video output format. A horizontal cropping function also included in this block.

Fast Switch Parameter RAM

The DM5886 features a patented hardware video source fast switch function. The Fast Switch block has a table which stores video characteristic. Each time HW switches to a previously tracked video source it could complete video synchronization within several lines. With this feature, the DM5886 can decode up to 8 CVBS with little frame rate loss.

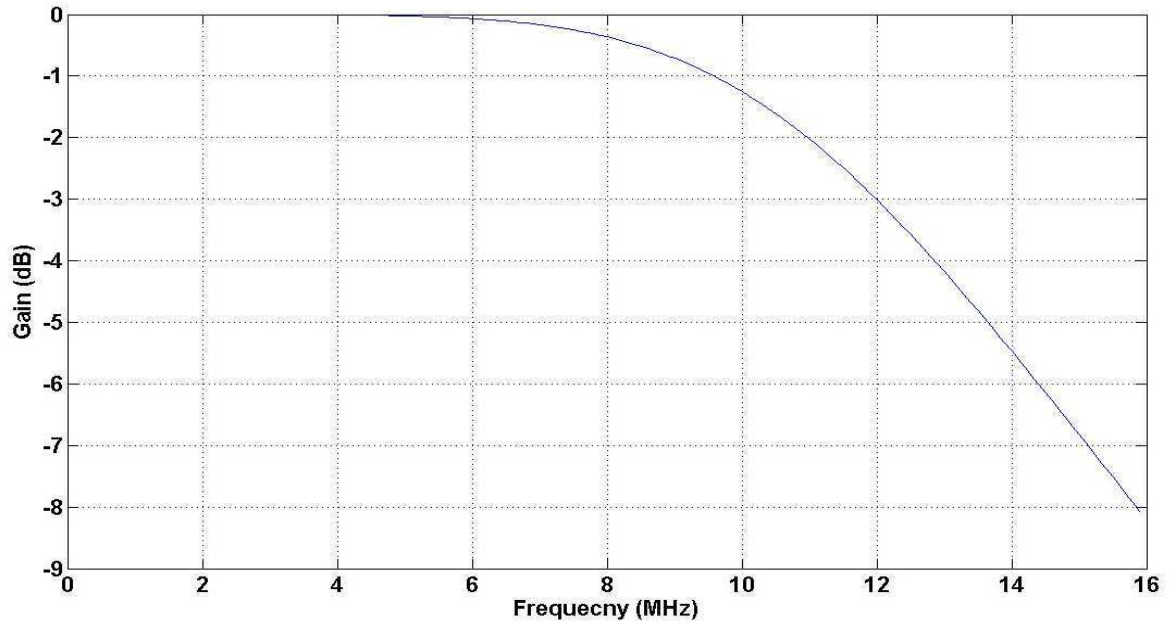
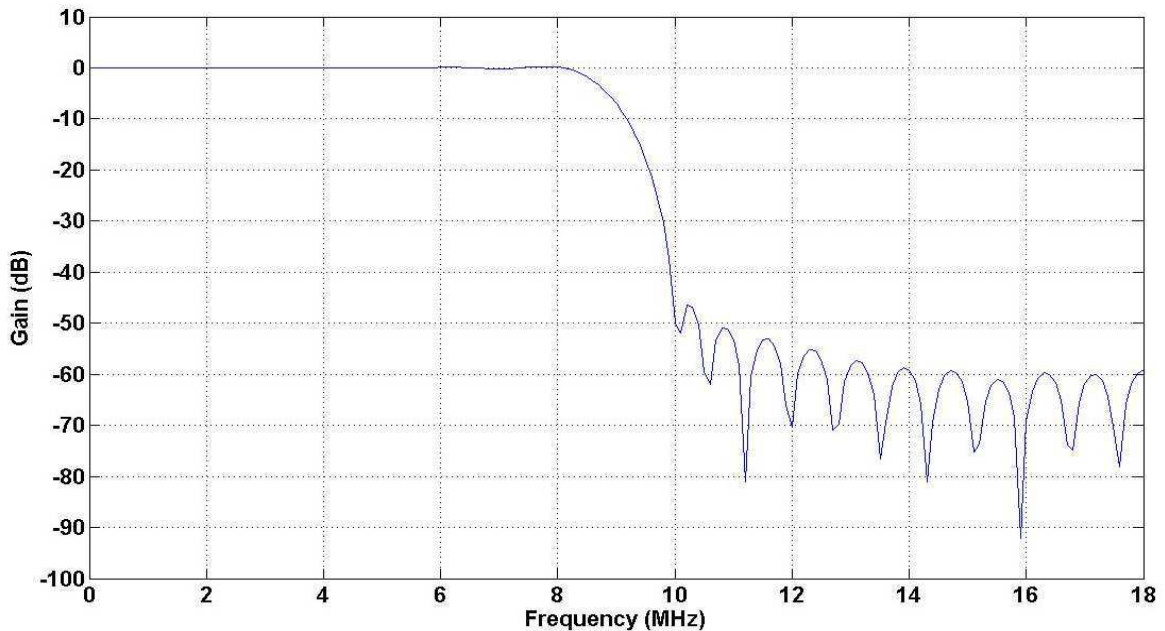
Filter response**Anti-alias LPF (960H)****Decimation filter (960H)**

Luma notch filter (960H)

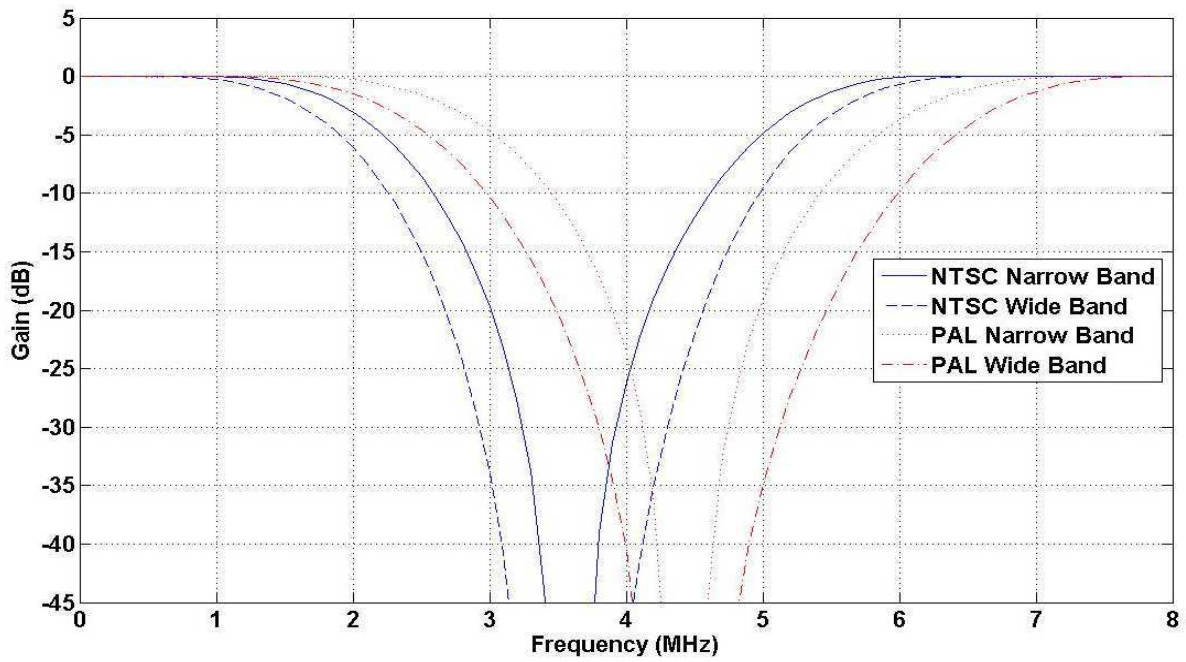

Chroma band pass filter (960H)

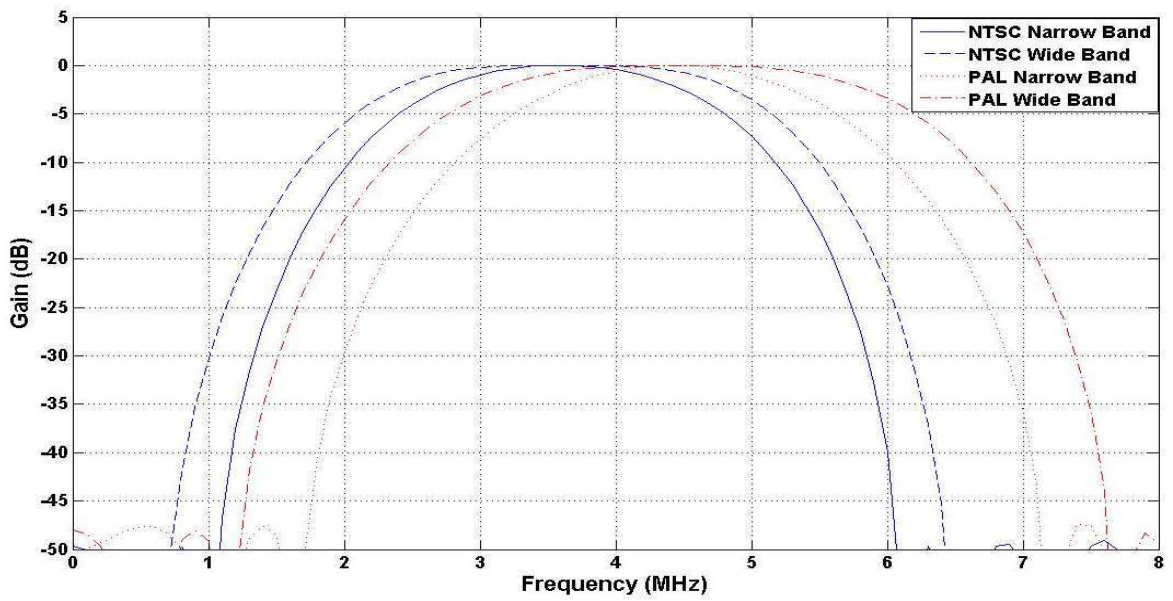

Y sharpness filter (960H)

■ **NSTC**

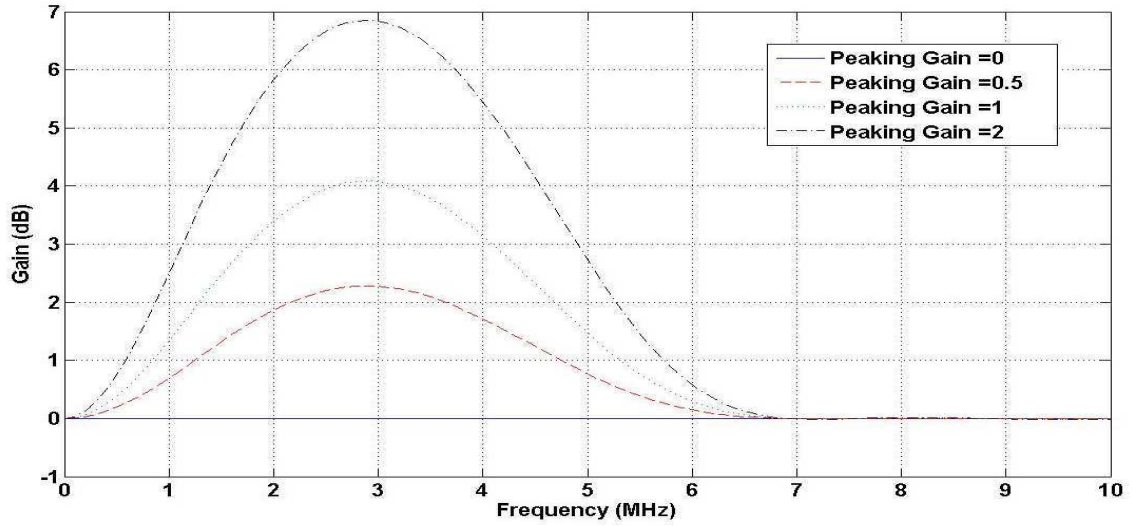

■ **PAL**

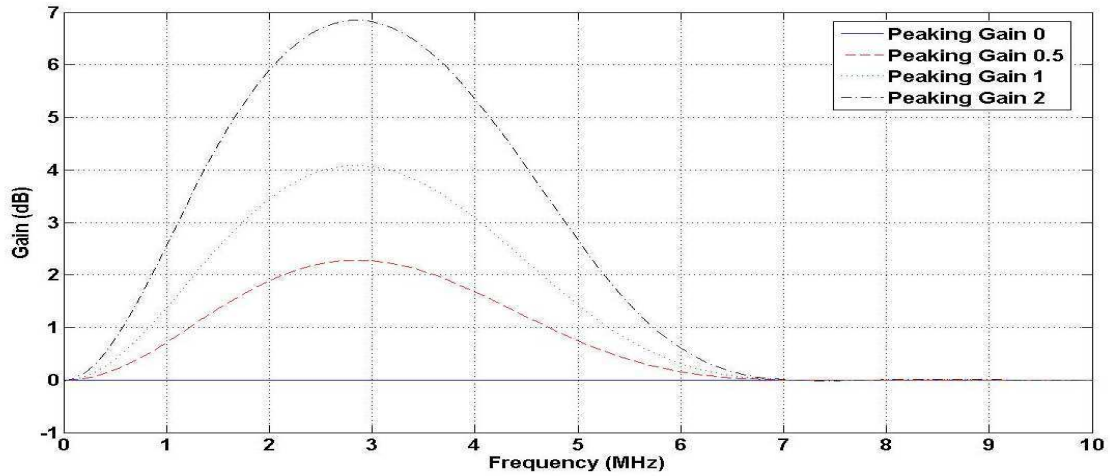

UV demodulation low pass filter (960H)

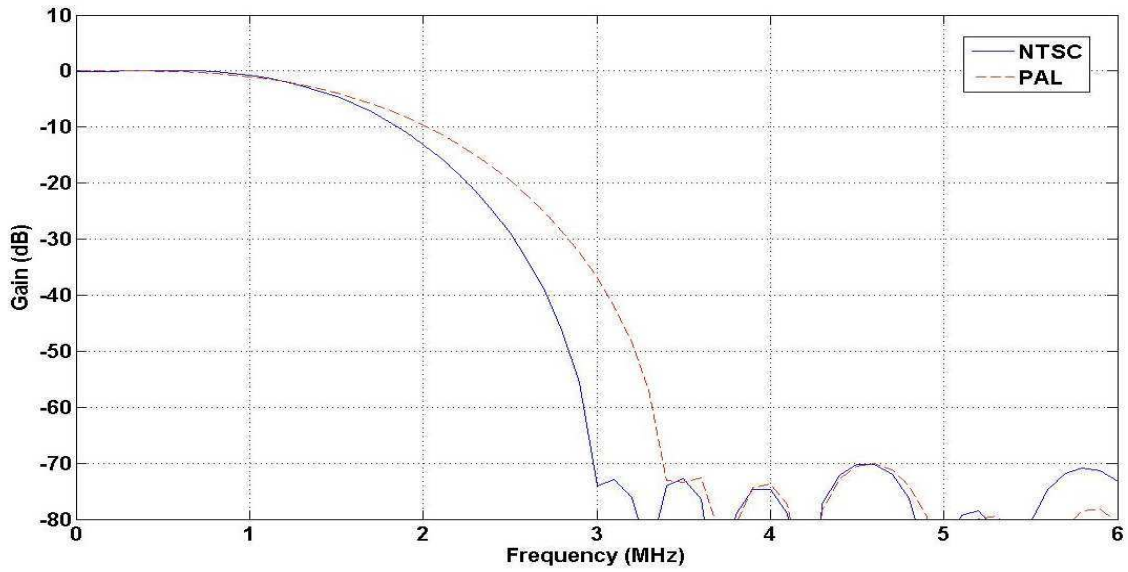

Anti-alias LPF (720H)

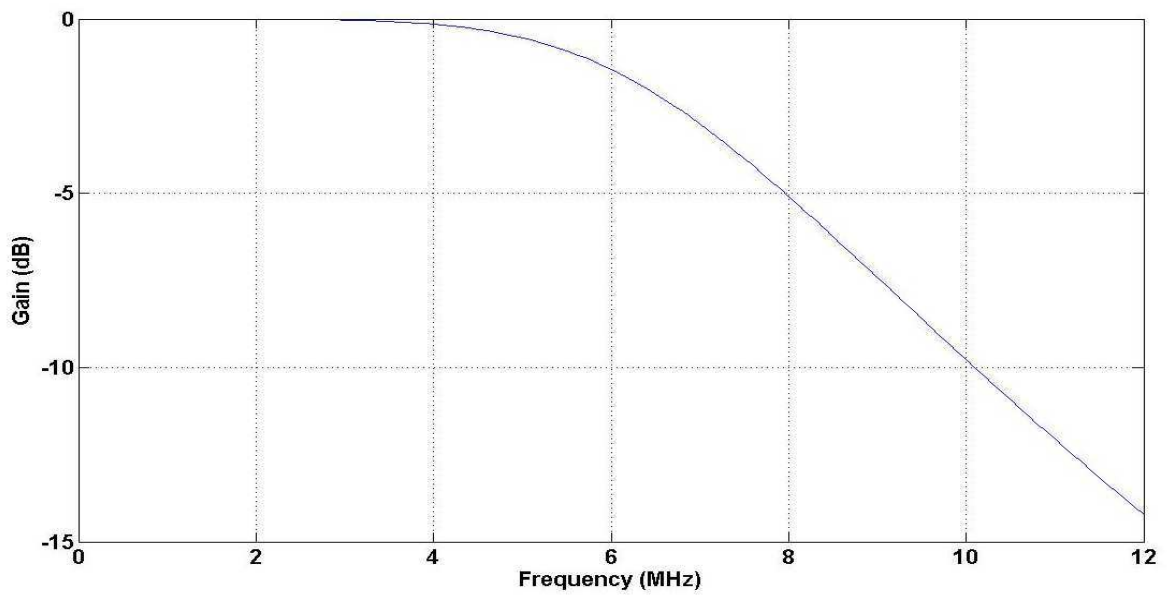

Decimation filter (720H)

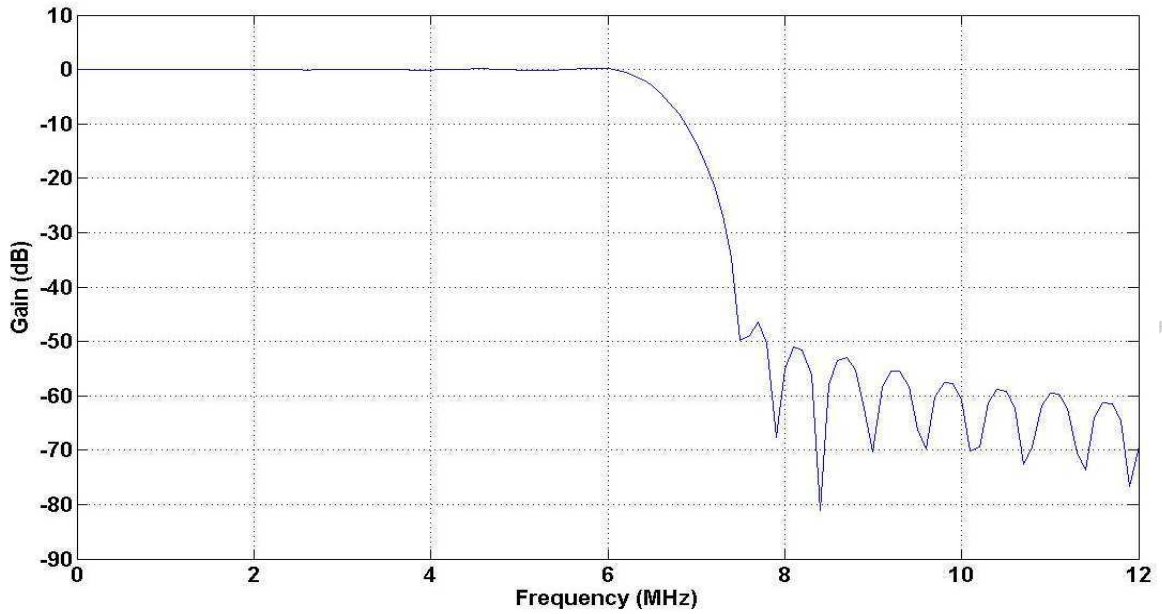

Luma notch filter (720H)

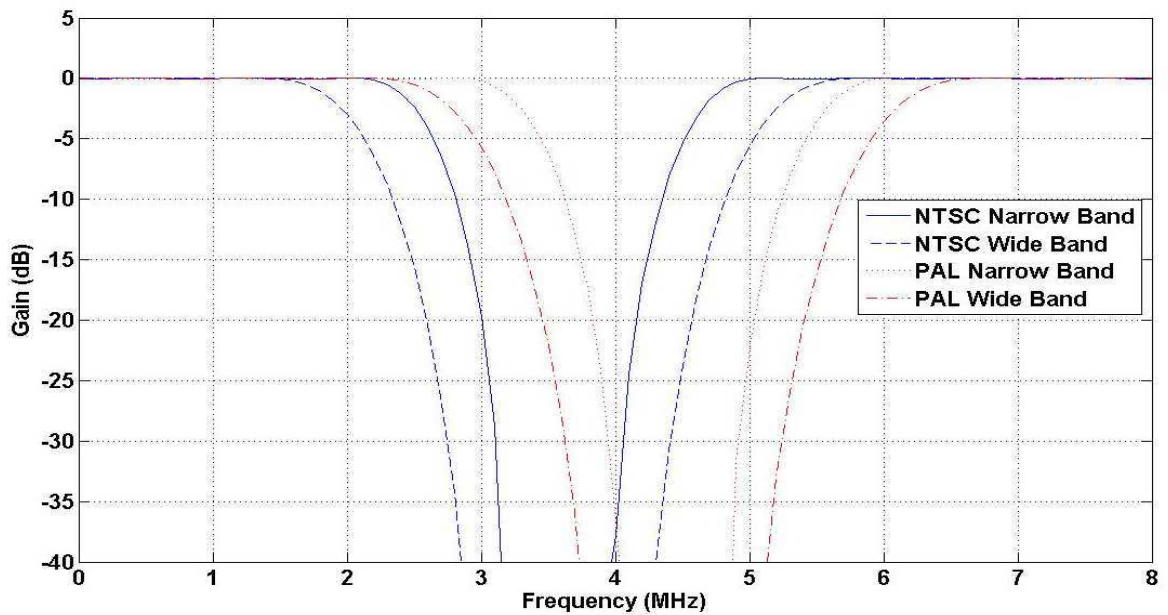

Chroma band pass filter (720H)

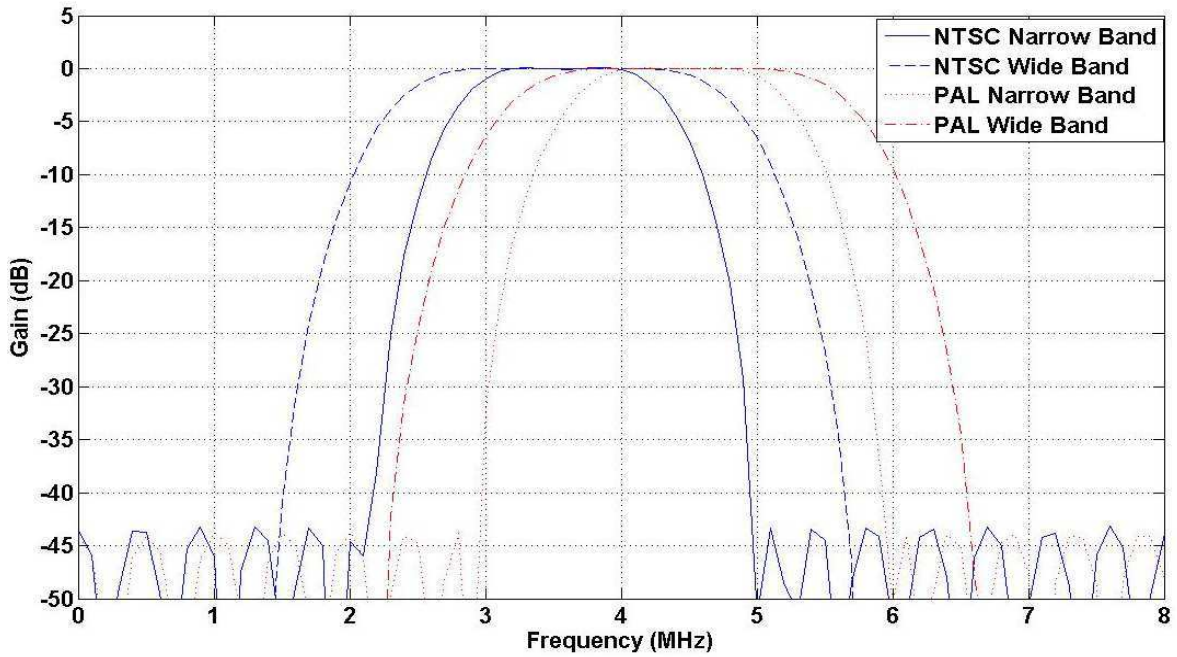

Y sharpness filter (720H)

■ NTSC

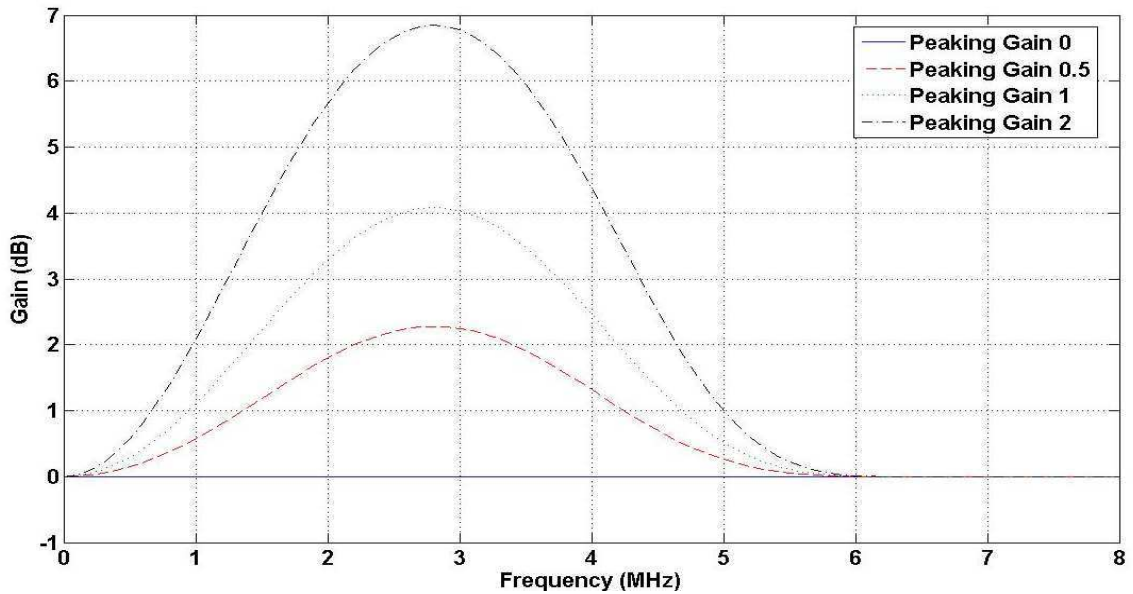

■ PAL

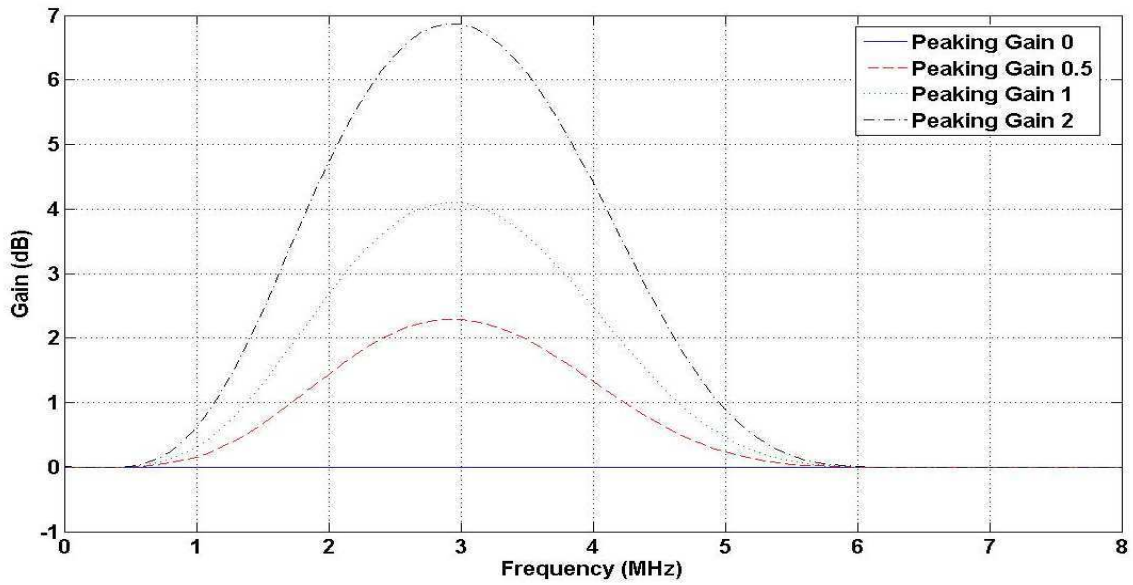

UV demodulation low pass filter (720H)

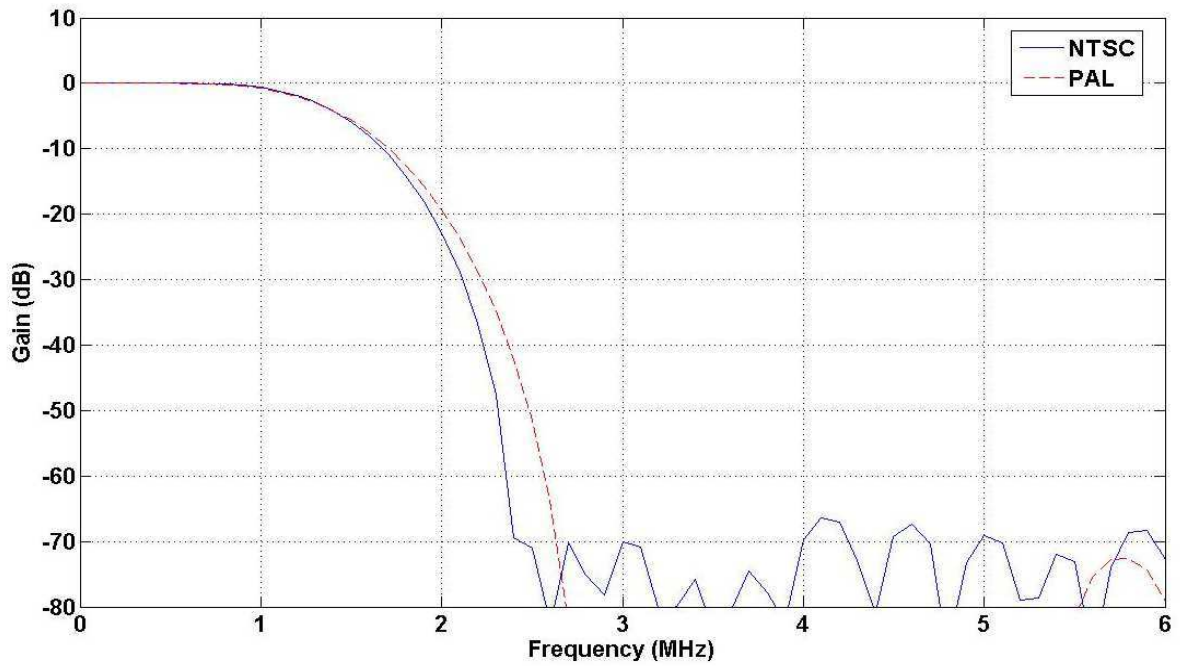

Audio CODEC

The audio codec in the DM5886 consists of five audio ADCs, one audio DAC, one audio mixer, one I2S/DSP decoder and two I2S/DSP encoders as shown below. The I2S/DSP decoder and encoders always operate in the master mode.

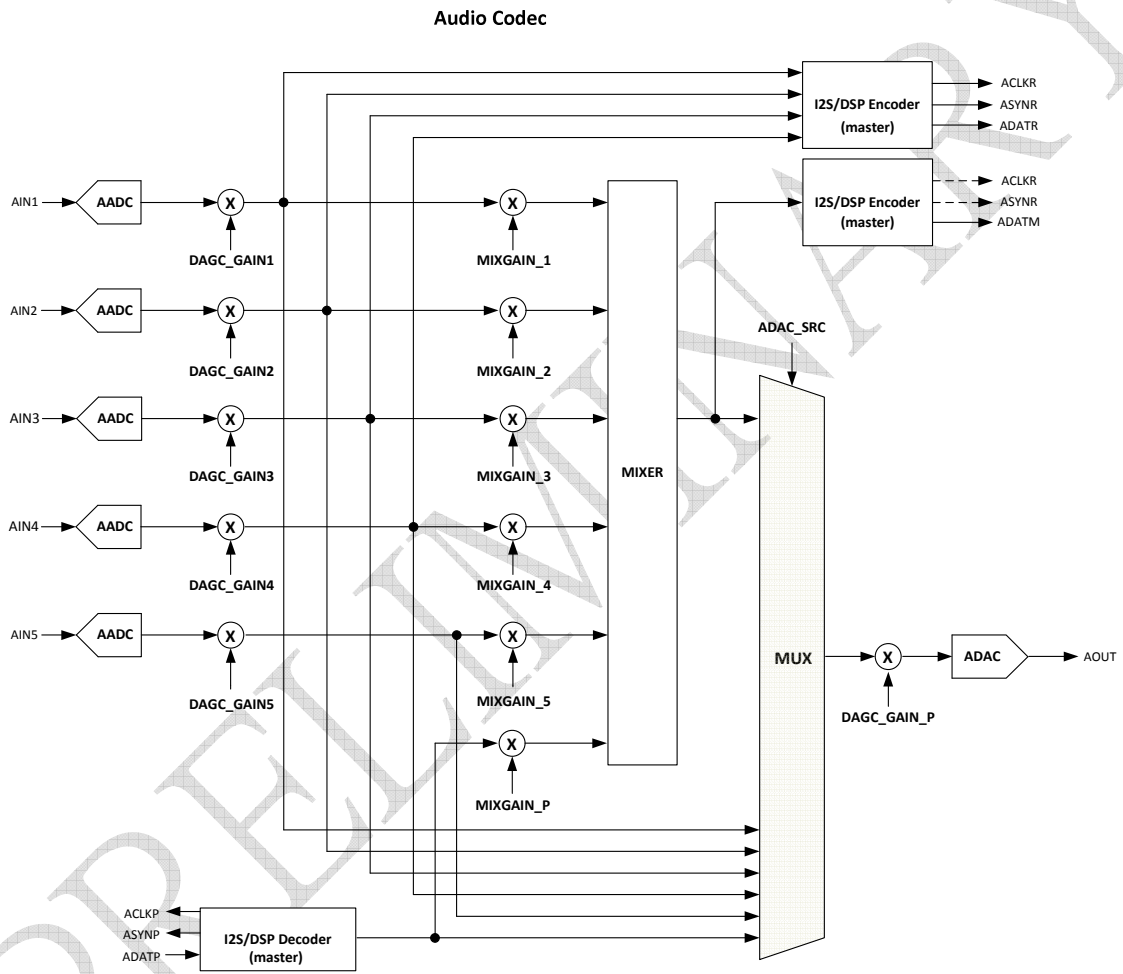

The I2S/DSP decoder is used for playback of digital input. It generates ACLKP and ASYNP signals and accepts serial data via ADATP from a slave device. The levels of the five analog audio inputs (AIN1 ~ AIN5) are programmable via the registers DAGC_GAIN1, DAGC_GAIN2, DAGC_GAIN3, DAGC_GAIN4 and DAGC_GAIN5. The six input audio sources can be mixed by the user-defined ratio specified by registers MIXGAIN_1, MIXGAIN_2, MIXGAIN_3, MIXGAIN_4, MIXGAIN_5, MIXGAIN_P. The mixed audio can be output through I2S/DSP encoder or DAC.

The codec provides three interfaces for audio output. The audio DAC can output analog audio for any one of the six input audio sources or the mixed audio. The analog output level is adjustable via register DAGC_GAIN_P. Two I2S/DSP encoders are present to output digital audio signal. The first one generates ACLKR, ASYNR and ADATR to output the 4 recorded audio inputs. The second encoder uses ADATM and shares the other two signals (ACLR and ASYNR) to output the mixed audio.

The codec also supports audio cascade mode for multi-chip operation which will be described in a dedicated section.

Digital Audio Format

The 3 digital audio interfaces (decoder for playback and encoder for record or mixing) follow the standard I2S or DSP protocol as shown below. Only master mode (codec being the master) is supported.

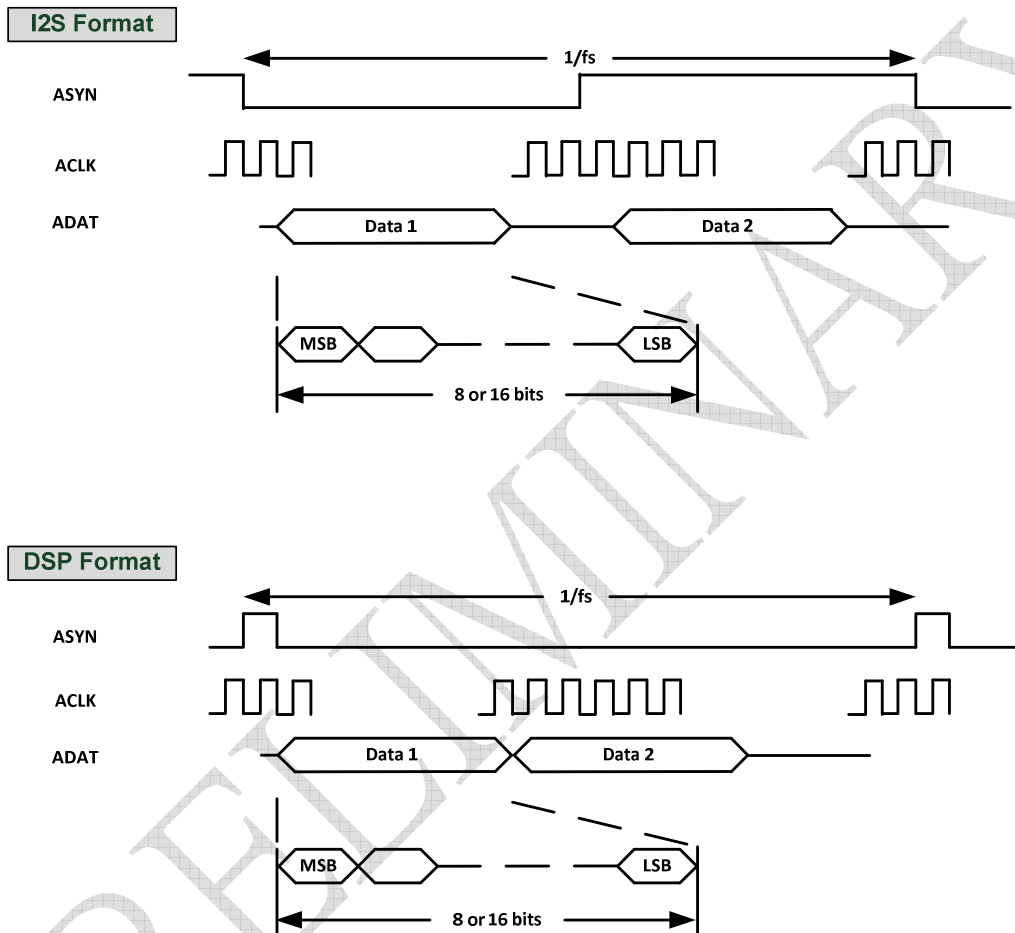

Extended Digital Audio Format

The digital audio encoders also support an extended I2S/DSP format to carry multiple audio channels through a single ADAT pin as shown below.

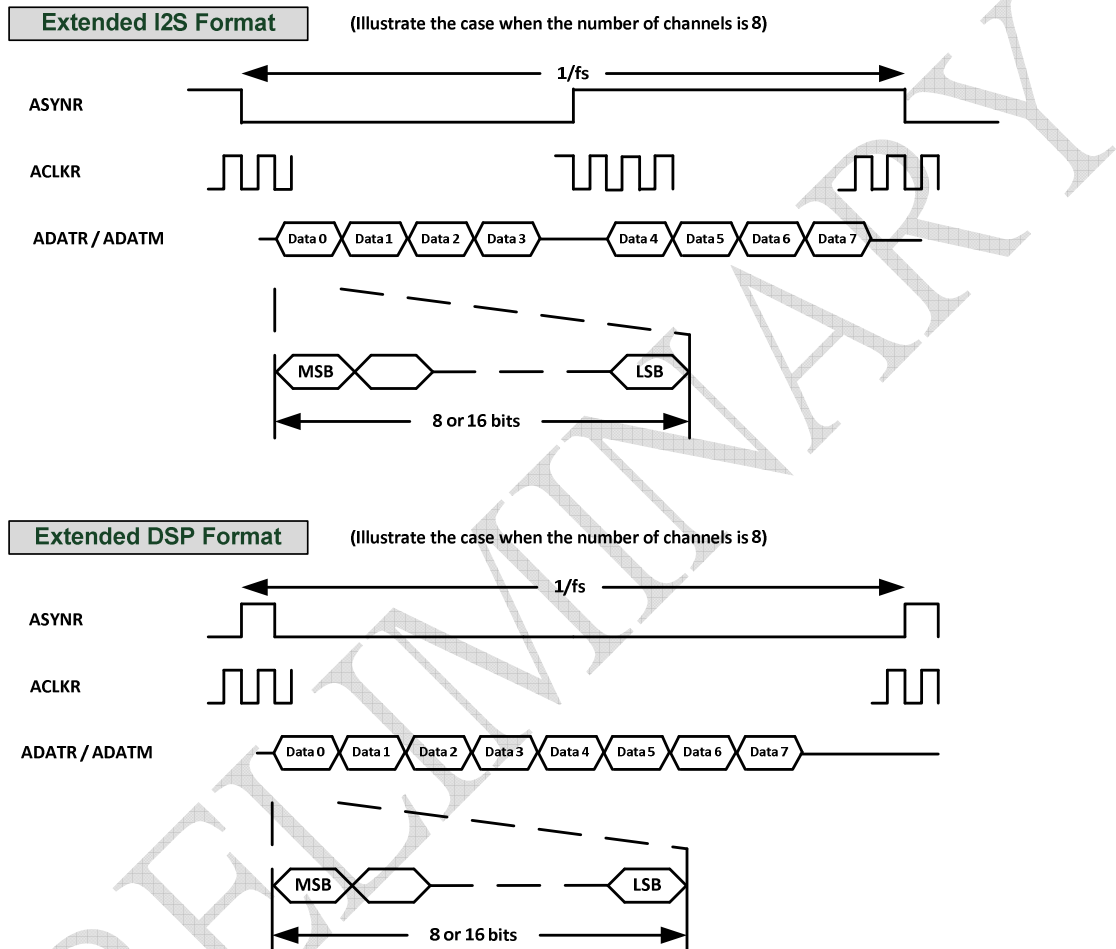

Cascade Mode for Multi-Chip Operation

By using audio cascade mode, up to 16 analog audio sources can be cascaded and output through a single ACLKR/ASYNR/ADATR interface using the extended I2S/DSP format. Hence up to 4 chips can be cascaded in multi-chip application. A typical audio cascade system is shown below.

The table shown below summarizes the operation of audio cascade mode for various system configurations. Please note that 16-bit I2S/DSP data is not supported when using 16-channel cascade.

The analog audio input AIN5 can be optionally cascaded and output using the ADATM pin by setting the registers **MIXCASEN** and **ADATMOPT** as '1'.

	2-chip cascade (8 channels)		3-chip cascade (12 channels)		4-chip cascade (16 channels)	
	8-bit data	16-bit data	8-bit data	16-bit data	8-bit data	16-bit data
fs=48KHz	supported	supported	supported	supported	supported	prohibited
fs=24KHz	supported	supported	supported	supported	supported	prohibited
fs=16KHz	supported	supported	supported	supported	supported	prohibited
fs=8KHz	supported	supported	supported	supported	supported	prohibited

The Operation of Audio Cascade Mode for Various System Configurations

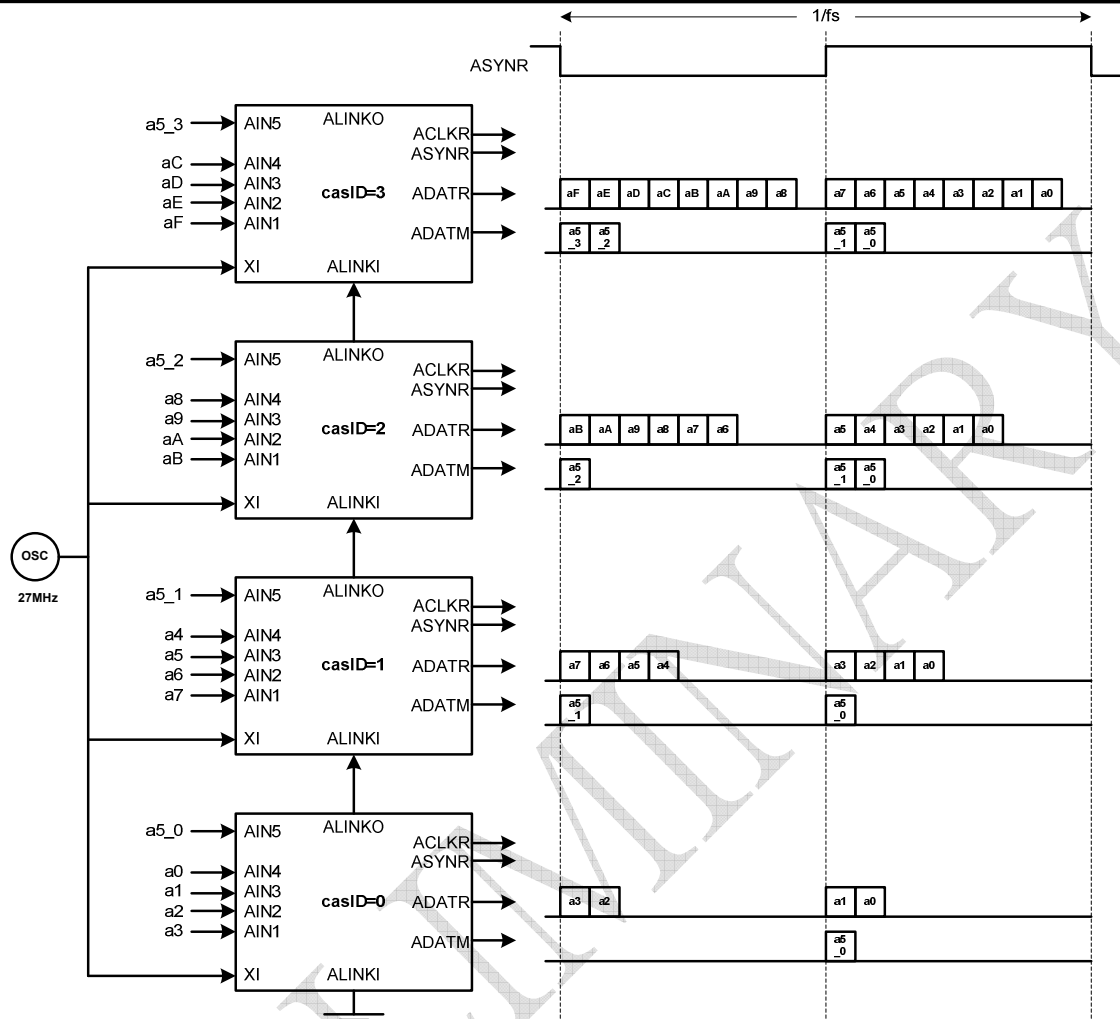

A Typical Audio Cascade System

<Note>

1. Here we use I2S mode as an example. The DSP mode works accordingly.
 2. The waveform is a simplified version.
- In real system the "ASYNR" signals in different cascade stages are not synchronous.

PLL

The DM5886 has two internal PLLs to generate the system and pixel clocks. A 27MHz or 36 MHz is required for the PLLs.

The default PLL setting is shown in the following table.

	Crystal In clock (MHz)	PLL out (MHz)	Function
PLL1	27	144	System/pixel clock
PLL2	27	74.25	SMPTE 274M pixel clock

PLL default operated clock

The PLL parameters for various system configurations are shown in the following table.

	Crystal(MHz)	PLL out(MHz)	M	N	OD
PLL1	27	144	64(62+2)	6(4+2)	1
	27	108	16(14+2)	2(0+2)	1
	36	144	16(14+2)	2(0+2)	1
	36	108	12(10+2)	2(0+2)	1
PLL2	27	144	64(62+2)	6(4+2)	1
	27	108	16(14+2)	2(0+2)	1
	27	74.25	22(20+2)	2(0+2)	2
	36	144	16(14+2)	2(0+2)	1
	36	108	12(10+2)	2(0+2)	1
	36	74.25	66(64+2)	8(6+2)	2

Host Interface

In the DM5886, I²C is used for setting configuration and parameters, for example, brightness, contrast, saturation, hue, and sharpness control. The typical timing diagram of I²C write and read access is illustrated in the following figure.

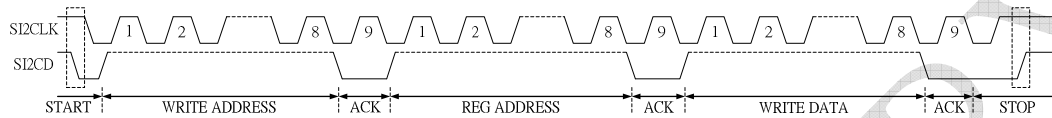

Write operation of I²C bus

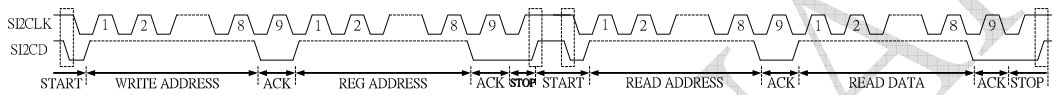

Read operation of I²C bus

Write/Read Address							
Slave Address						R/W	
1	1	0	0	0	SADD[1]	SADD[0]	0: Write; 1: Read

The external Pull-up/Pull-down resistors connected to the pins “DQ0” and “DQ1” indicate the device address SADD[1] and SADD[0]. When pull-up resistor is connected to DQ0 or DQ1, it indicates SADD[1] or SADD[0] with a high value. Otherwise when pull-down resistor is connected to DQ0 or DQ1, it indicates SADD[1] or SADD[0] with a low value.

	Write Address	Read Address
SADD[1:0]=2'h0	C0	C1
SADD[1:0]=2'h1	C2	C3
SADD[1:0]=2'h2	C4	C5
SADD[1:0]=2'h3	C6	C7

Video Mixer

The video mixer in the DM5886 is composed of four capture interfaces, two mixer cores, one SDRAM controller and two mix-out interfaces (**MIX_CCIROUT_X**) as shown below. The **MIX_CCIROUT_0** is the main output interface, while an auxiliary path (through **MIX_CCIROUT_1**) is available for SD mode when **OUTSEL** is configured as 4 or 5.

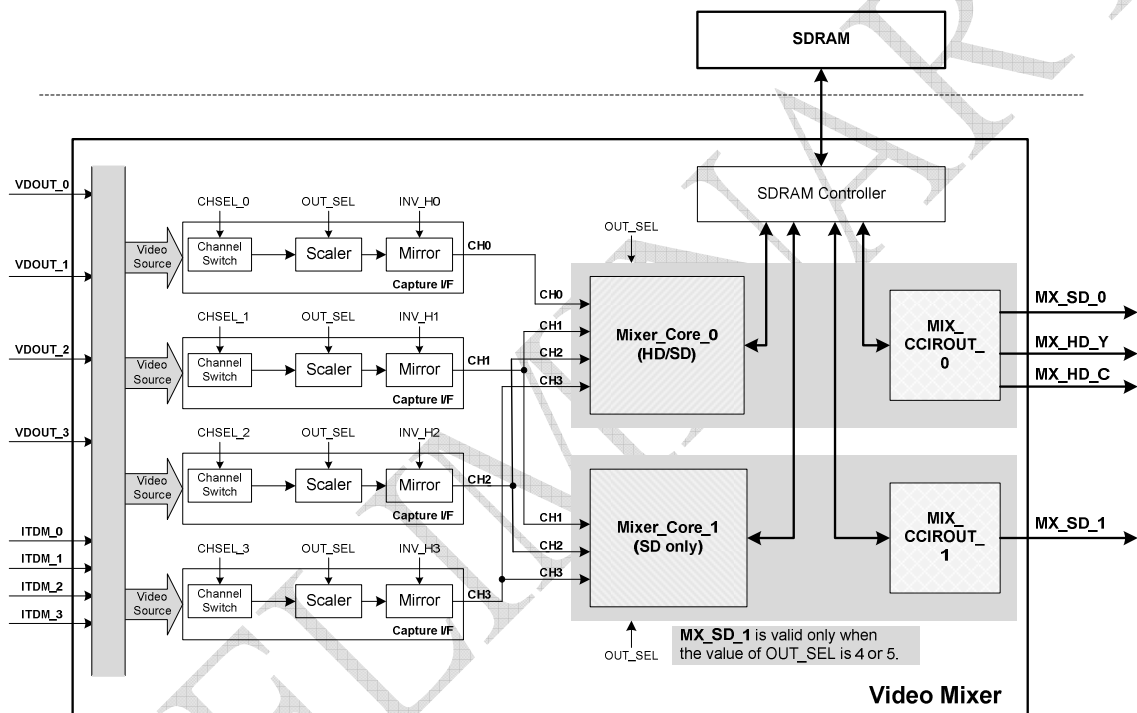

Block Diagram of Video Mixer

Output format

In addition to 27MHz BT.656 with 720x480/720x576 resolution or 36MHz BT.1302 with 960x480/960x576 resolution, the DM5886 mixer could support 74.25MHz SMPTE 274M 1920x1080 interface.

SMPTE 274M contains 16-bit data bus and 1-bit clock bus. Thus two output ports are used for one HD format. Here luminance and chrominance data are transmitted through different ports. The output timing diagram is shown below.

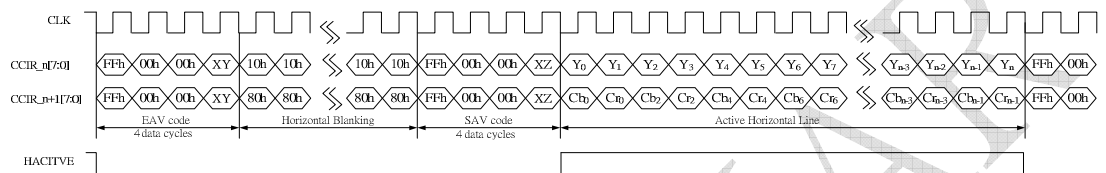

For 1920x1080 HD video outputs, the active horizontal line contains 1920 cycles. The definition of SAV and EAV code sequences is the same as that in 720H and 960H video outputs.

Video Mixer Block

Video Source

The video mixer accepts eight input sources (**VDOUT_0 ~ VDOUT_3**, **ITDM_0 ~ ITDM_3**). The input source **VDOUT_X**, digital version of the input CVBS, comes from the internal video decoder. As shown in the figure, users are flexible to select any one from the input CVBS pair for **VDOUT_X** by programming the control registers (**SW_sel_1**, **SW_sel_2**) of the analog MUX. The **ITDM_X** is the decoded TDM input for a specific Channel ID.

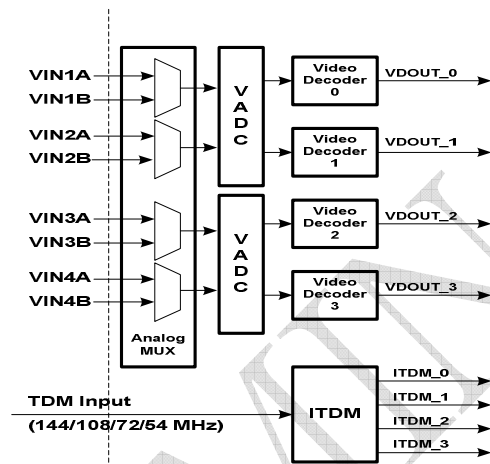

Video Source of Video Mixer

Channel Switch Block

There are four capture interfaces in the video mixer. Within each capture interface, a channel switch is used to select the desired video source. This selection is fully programmable by registers **CHSEL_0**, **CHSEL_1**, **CHSEL_2** and **CHSEL_3**, allowing any one of the eight mixer inputs to be selected. The following table determines the mapping between **CHSEL_X** and the selected video.

CHSEL_X	0	1	2	3	4	5	6	7
Selected Video	VDOUT_0	VDOUT_1	VDOUT_2	VDOUT_3	ITDM_0	ITDM_1	ITDM_2	ITDM_3

Capture interface

The following figure is the block diagram of channel video capture interface. The video source is selected by the channel switch for the specific channel. Video signal detection detects valid signal and format. It is then horizontally cropped, scaled, and horizontally mirrored if necessary. The detailed functions of these modules are described in the following sections.

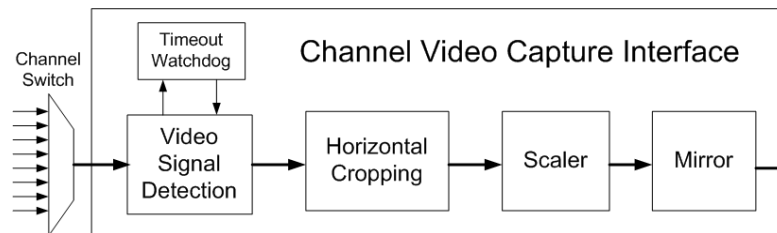

Video Signal Detection

Video signal detection module detects if valid video signal exists. A timeout watchdog module monitors the time used by the detection module. If valid signal is detected within the pre-set time limit, the flag 'NOVID_x' is set to 0. Otherwise, it is set to '1'.

The module also detects the format of the channel signal. 'H960_DET_x' is 1 when 960H video source is detected. 'H720_DET_x' is 1 when 720H video source is detected. 'L625_DET_x' is 1 when PAL video source is detected. 'L525_DET_x' is 1 when NTSC video source is detected.

Horizontal Cropping

The input video source can be cropped horizontally for output. It is illustrated in the following figure. 'Crop_start_point', which indicates the position to start cropping, is set in the registers 0xC3 to 0xC6. 'Crop_start_point' can be specified for each channel. 'Crop_length', which indicates the length for cropping, is set in the registers 0xA4 and 0xA5. The same value is used for all channels. If 1/4 horizontal scaling is performed in any channel, it should be set to a multiple of 4. Otherwise, if 1/2 horizontal scaling is performed in any channel; it should be set to a multiple of 2.

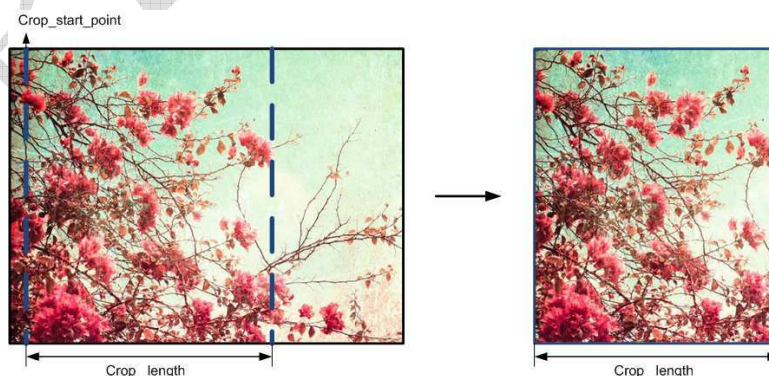

Scaler

DM5886 supports several kinds of partition modes. It can be configured with the register 'OUT_SEL' (0xA0). According to the mode selection, the output of each channel should be scaled to be combined to a new frame for output. The following figure shows the settings of 'OUT_SEL' and the corresponding output formats. Here 720H NTSC video source is used as an example.

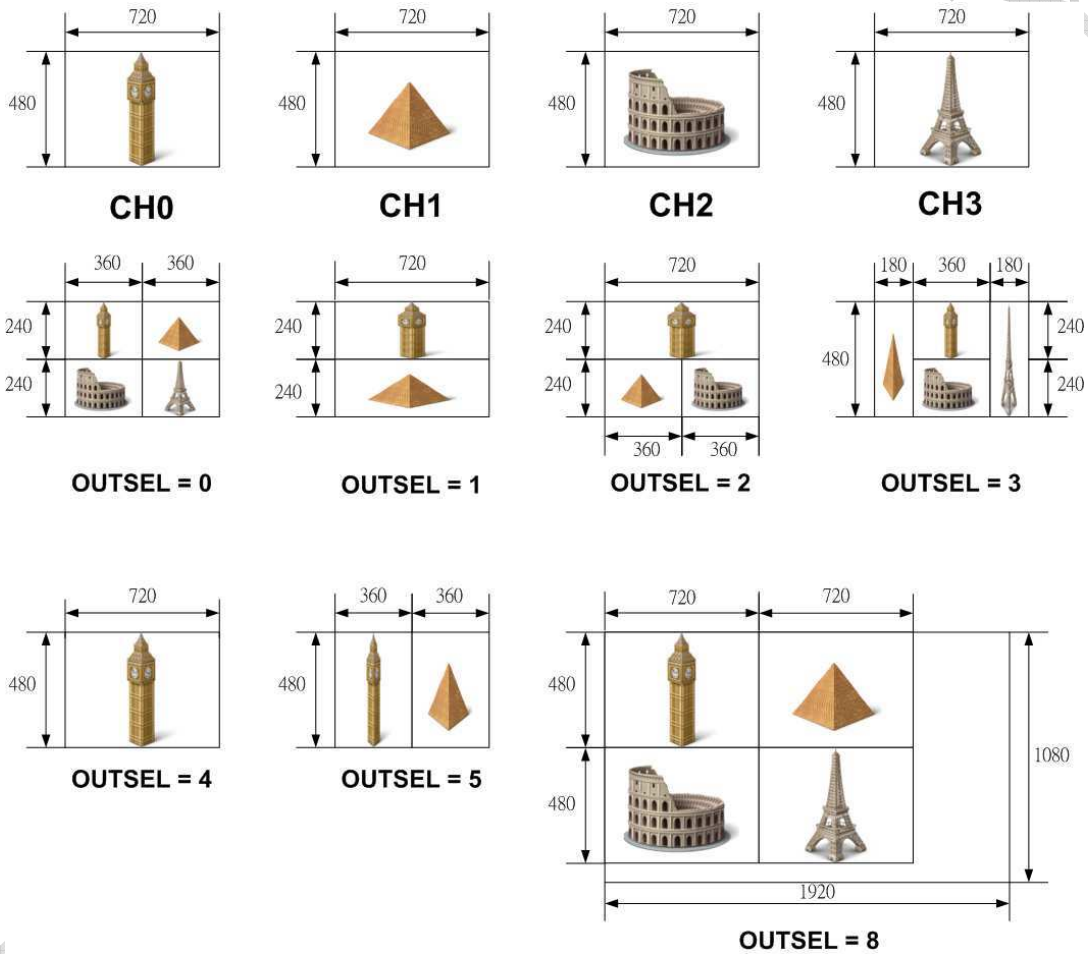

The following table shows the scaling ratios at the horizontal direction and the vertical direction with different 'OUT_SEL' settings.

		OUT_SEL						
		0	1	2	3	4	5	8
CH0	H	1/2	1	1	1/2	1	1/2	1
	V	1/2	1/2	1/2	1/2	1	1	1
CH1	H	1/2	1	1/2	1/4	-	1/2	1
	V	1/2	1/2	1/2	1	-	1	1
CH2	H	1/2	-	1/2	1/2	-	-	1
	V	1/2	-	1/2	1/2	-	-	1
CH3	H	1/2	-	-	1/4	-	-	1
	V	1/2	-	-	1	-	-	1

When horizontal scaling is performed, decimation filter is applied on input samples. The filtered samples are then decimated according to the scaling ratio. The following figure shows the frequency response of the decimation filter at the horizontal scaling process.

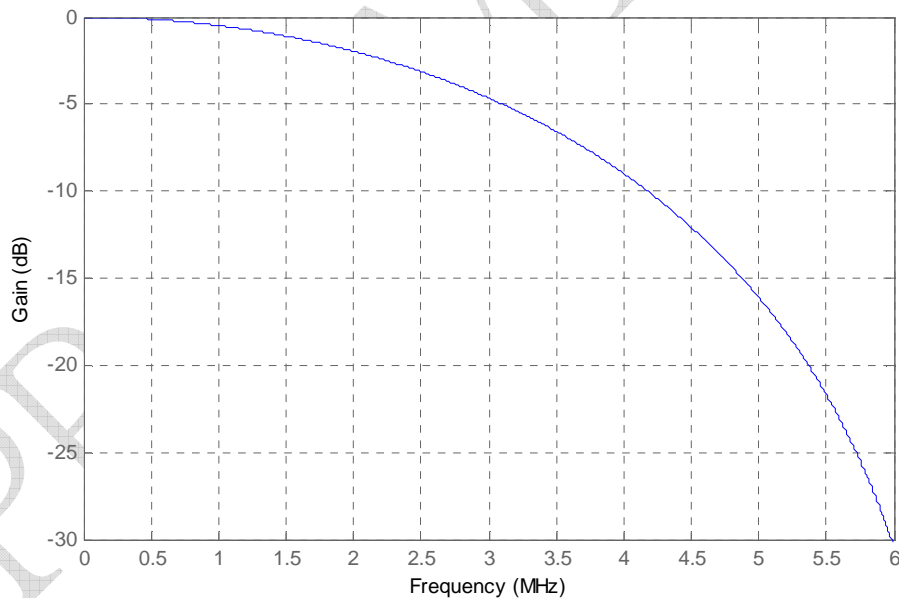

When the display width is a quarter of the original width, in addition to 1/4 down scaling at the horizontal direction, 1/4 input frame cropping can be chose. The most significant four bits of the register 'Mirror Config' (0xBD) are used to indicate the input frame cropping. When 'H_x_L' is set to 1, the left quarter of channel x is cut for display. When 'H_x_R' is set to 1, the right quarter of channel x is cut for display. When 'H_x_L' and 'H_x_R' are both set to 0, 1/4 down scaling is performed. The following figure illustrates the settings of 'H_x_L' and 'H_x_R'.

Please note that 1/4 input frame cropping can only be supported at SD mode and 'OUT_SEL' is set to 3.

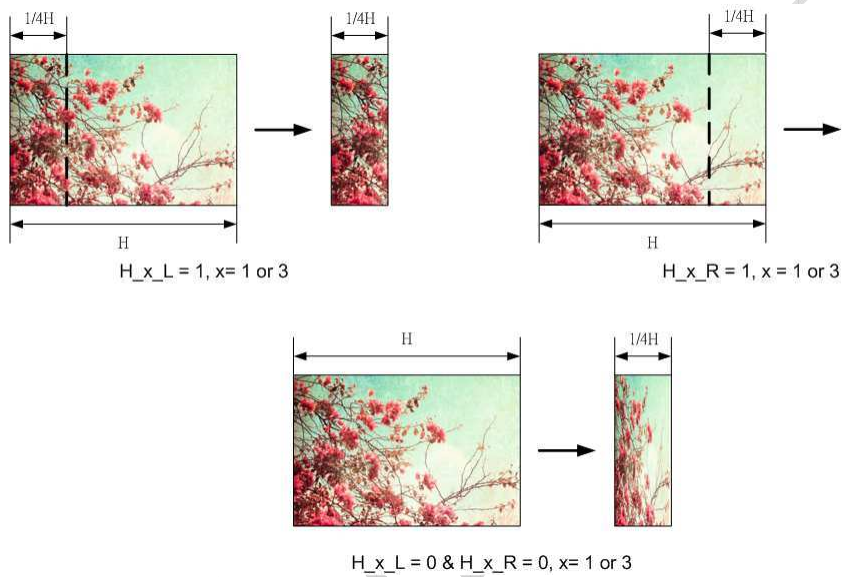

Vertical scaling uses simple line dropping algorithm. No averaging operation is performed. The following figure illustrates the process. Top field is used for output.

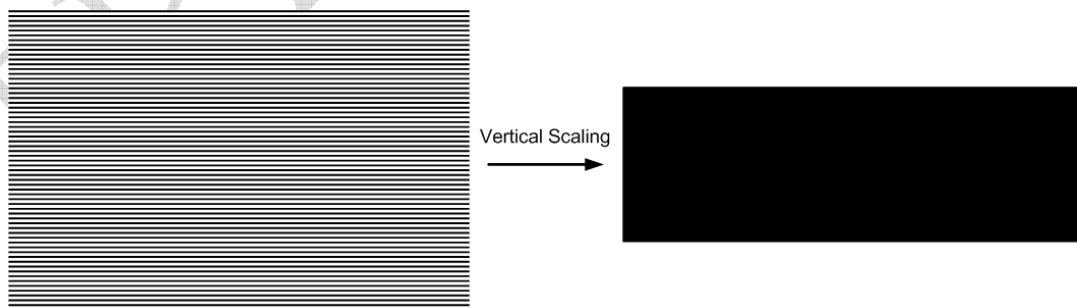

Mirror

When horizontal mirroring is performed, the samples at each line are left-right flipped. Please note that horizontal mirroring is only supported at SD mode. Each output channel can be assigned to be mirrored or not. The last four bits of the register 'Mirror Config' (0xBD) are used to indicate the mirrored output channels. When 'INV_Hx' is set to 1, the output picture of channel x is mirrored at the horizontal direction. The following figure illustrates the result of horizontal mirroring.

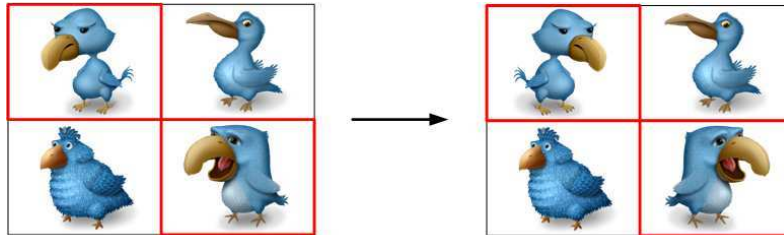

OUTSEL = 0, INV_H0 = 1, INV_H1 = 0, INV_H2 = 0, INV_H3 = 1

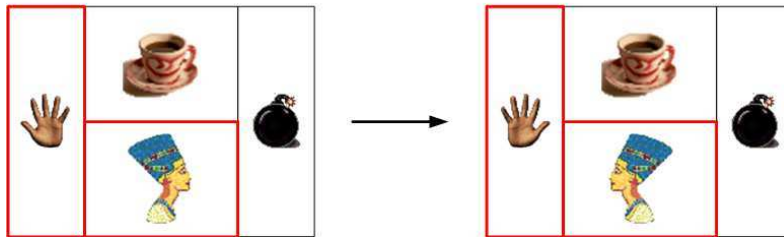

OUTSEL = 3, INV_H0 = 0, INV_H1 = 1, INV_H2 = 1, INV_H3 = 0

Mixer Core

There are two mixer cores mixing up to four video data (**CH0**, **CH1**, **CH2** and **CH3**) coming from the capture interface. The mixed video is then stored into the SDRAM. The **Mixer_Core_0** is a full-function mixer supporting both HD and SD resolution. **Mixer_Core_1** is a secondary mixer which is only valid for SD mode when **OUTSEL** is programmed as 4 or 5. The mixing process is determined by the value of the register **OUTSEL** as shown in the following figure.

Mix-Out Interface

The mix-out interface retrieves mixed video from the SDRAM. The mixed video then goes to the chip-level output unit to form a variety of output combinations. Users are flexible to specify the output format as progressive or interlaced. The **MIX_CCIROUT_0** is the main mixer output unit supporting both SD and HD resolution. For SD mode, **MX_SD_0** is output. In case of HD mode, **MX_HD_Y** is output for luminance and **MX_HD_C** is output for chrominance. Another mixed video **MX_SD_1** from **MIX_CCIROUT_1** is available if **OUTSEL** is configured as 4 or 5. **MX_SD_1** is always of SD resolution. The combined usage of **MIX_CCIROUT_0** and **MIX_CCIROUT_1** is shown in the following figure.

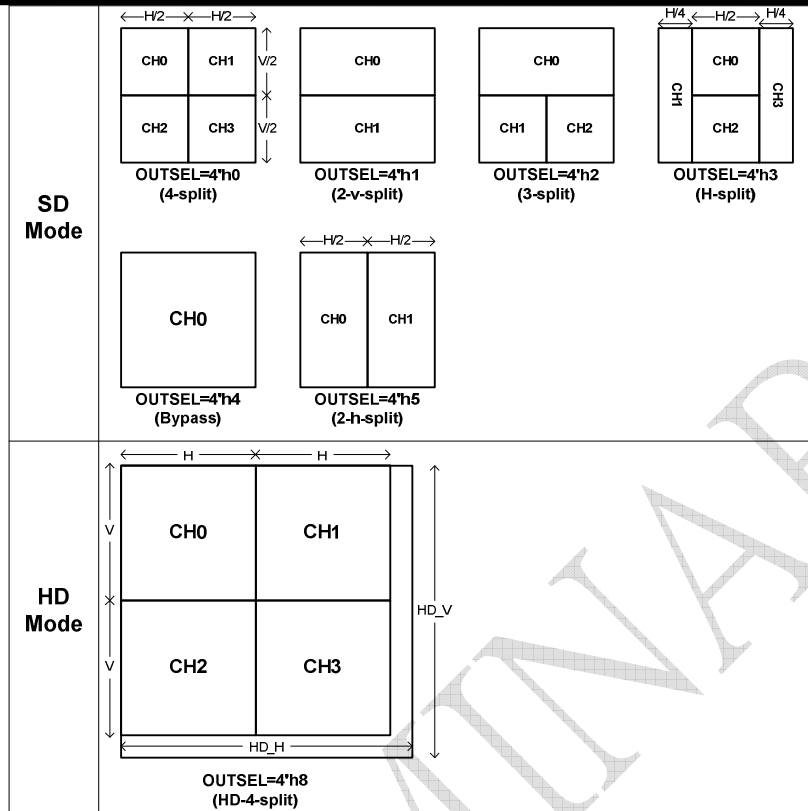

OUT_SEL=0~5 : SD mode (H=720 or 960, V=480 or 576)
 OUT_SEL=8 : HD mode (HD_H=1920, HD_V=1080 or 1152)
 Other values : prohibited

Value of OUTSEL and the Corresponding Partition Type

	MX_SD_0	MX_SD_1
OUTSEL=4'h4	 CH0	 CH1
OUTSEL=4'h5	 CH0 CH1	 CH2 CH3

**The Combined Usage of the two Mixer Outputs
 (Only Valid When OUTSEL=4 or OUTSEL=4)**

Video Rendering

The output frame is divided into several partitions according to 'OUT_SEL'. The following table shows the coordinates of left-top point and right-bottom point of the partitions with different values of 'OUT_SEL'. The input video width is denoted as W and the input video height is denoted as H.

	<table border="1"><tr><td>0</td><td>1</td></tr><tr><td>2</td><td>3</td></tr></table>	0	1	2	3	<table border="1"><tr><td>0</td></tr><tr><td>1</td></tr></table>	0	1	<table border="1"><tr><td>0</td></tr><tr><td>1</td><td>2</td></tr></table>	0	1	2	<table border="1"><tr><td>1</td><td>0</td><td>3</td></tr><tr><td>2</td></tr></table>	1	0	3	2	<table border="1"><tr><td>0</td></tr></table>	0	<table border="1"><tr><td>0</td><td>1</td></tr></table>	0	1	<table border="1"><tr><td>0</td><td>1</td></tr><tr><td>2</td><td>3</td></tr></table>	0	1	2	3
0	1																										
2	3																										
0																											
1																											
0																											
1	2																										
1	0	3																									
2																											
0																											
0	1																										
0	1																										
2	3																										
	OUT_SEL = 0	OUT_SEL = 1	OUT_SEL = 2	OUT_SEL = 3	OUT_SEL = 4	OUT_SEL = 5	OUT_SEL = 8																				
Partition 0	(0,0)	(0,0)	(0,0)	(W/4,0)	(0,0)	(0,0)	(0,0)																				
	(W/2,H/2)	(W,H/2)	(W,H/2)	(3W/4,H/2)	(W,H)	(W/2,H)	(W,H)																				
Partition 1	(W/2,0)	(0,H/2)	(0,H/2)	(0,0)	-	(W/2,0)	(W,0)																				
	(W,H/2)	(W,H)	(W/2,H)	(W/4,H)	-	(W,H)	(2W,H)																				
Partition 2	(0,H/2)	-	(W/2,H/2)	(W/4,H/2)	-	-	(0,H)																				
	(W/2,H)	-	(W,H)	(3W/4,H)	-	-	(W,2H)																				
Partition 3	(W/2,H/2)	-	-	(3W/4,0)	-	-	(W,H)																				
	(W,H)	-	-	(W,H)	-	-	(2W,2H)																				

The output of each channel will be rendered within the active region of the corresponding partition. The active region in each partition can be specified by defining its top-left coordinate (COR_Xn, COR_Yn). The length of the active region is the crop length multiplied by the scaling ratio. The vertical coordinate of the right-bottom point of the active region is the same as that of the corresponding partition. Channel output is horizontally shifted if the horizontal coordinate of the top-left point of the active region is different from that of the corresponding partition. However, if the vertical coordinate of the top-left point of the active region is different from that of the corresponding partition, pixel lines outside the active region are discarded. The following figure illustrated the relationship between partitions and active regions.

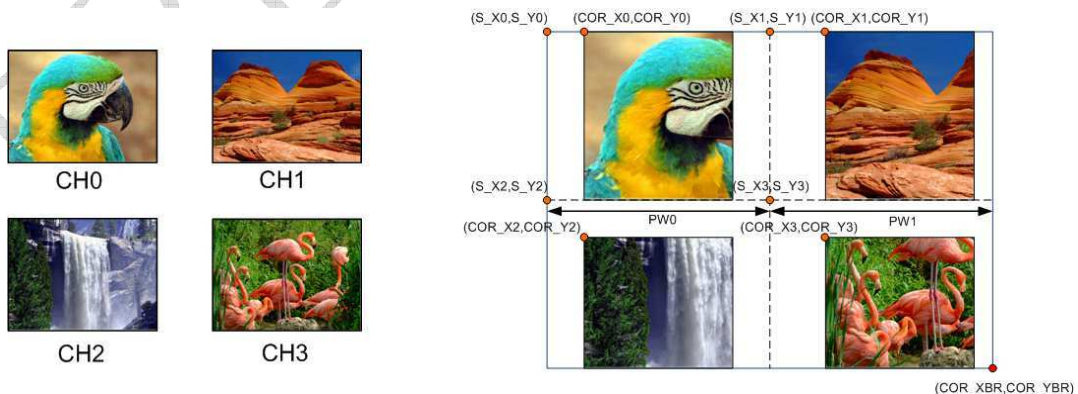

Several rules should be followed when specifying the coordinate (COR_Xn, COR_Yn).

1. The active region should not be outside the corresponding partition. If we define the coordinate of the left-top point of the partition to be (S_Xn,S_Yn) and the partition width to be PWn, the following condition should be satisfied:

$$\text{COR_Xn} + \text{Crop_length} * \text{H_scaling_ratio} \leq \text{S_Xn} + \text{PWn}$$

2. The settings of COR_Xn of the partitions, which have the same S_Xn, should also be the same.
3. If S_Yn is 0, COR_Yn should also be 0.
4. The settings of COR_Yn of partitions, which have the same S_Yn, should also be the same.

COR_XBR and COR_YBR specify the active region of the whole frame. It is recommended that it is set to the right-bottom point of the whole frame.

When the active region is smaller than the corresponding partition, the spacing in the region is regarded as split line. The color of the split line spacing can be assigned by the registers: 'Split_line_Y', 'Split_line_CB', and 'Split_line_CR' (0xD6 to 0xD8). The default color is white.

The following figure illustrates an example. The size of input and output video is 720x480 and 'OUT_SEL' is set to 3. The crop length is set to 704 and it creates horizontal split lines. COR_X0 and COR_X2 are set to 184 for center alignment. COR_X3 is set to 544 for right alignment. COR_Y2 is set to 244 to create a vertical split line with spacing of 4 pixels.

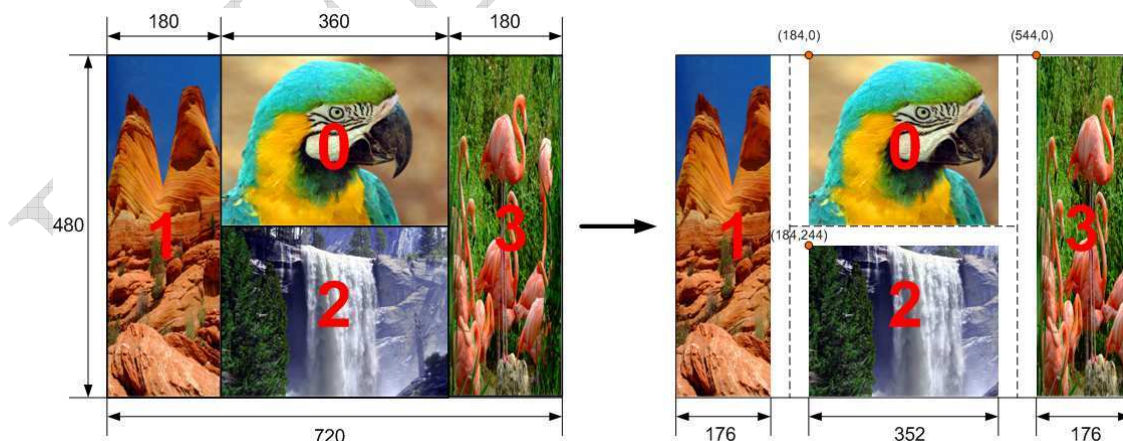

The following figure illustrates another example. The size of input and output video is 720x480 and 'OUT_SEL' is set to 8 (HD mode). The crop length is set to 704 and it creates horizontal split lines. COR_X1 and COR_X3 are set to 736 for center alignment. COR_Y2 and COR_Y3 are set to 488 to create a vertical split line with spacing of 8 pixels.

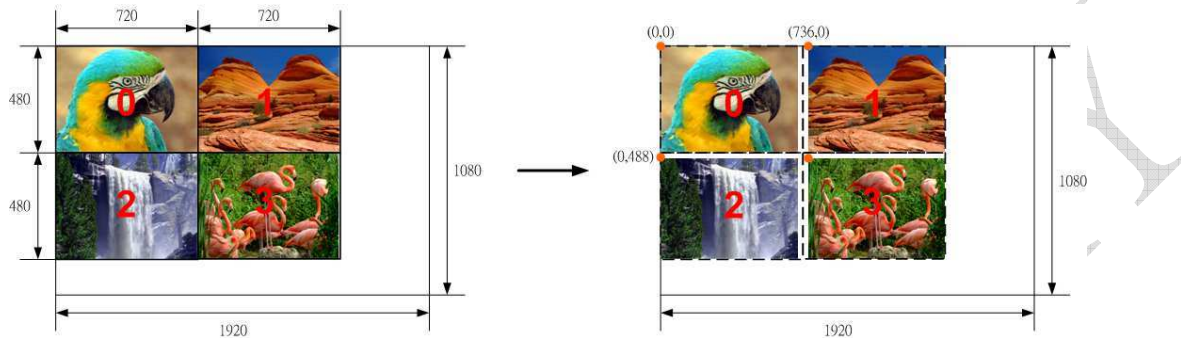

If the input channel is not valid, the corresponding output video will be displayed as blue panel. The following figure shows this condition. The display color of invalid video can also be designed with three registers: 'Blue_panel_Y', 'Blue_panel_CB', and 'Blue_panel_CR' (0xD3 to 0xD5). The default color is blue.

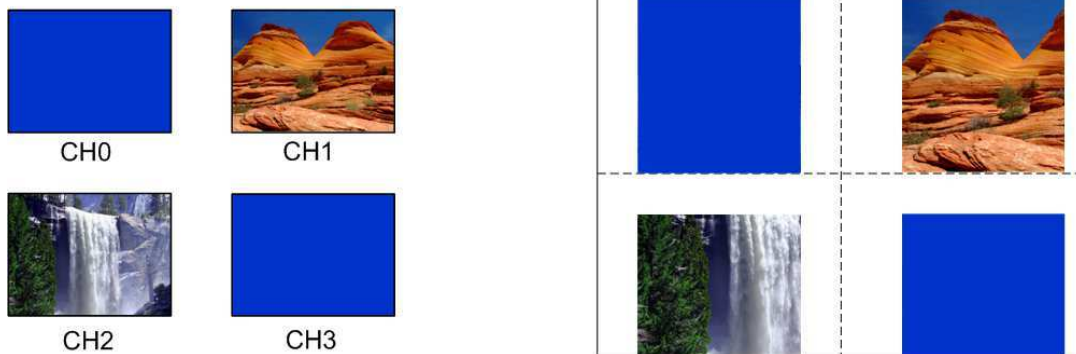

Please note that the above settings about video rendering are the same whether the output format is progressive.

Chip-Level Output Unit

Three video output ports are available at chip level. The following figure depicts the data path of output ports.

The output ports are flexible in use. It can be programmed to output various output combinations. As shown in the figure, the register **CCIROMX_m_n** is used to select up to 4 output videos from 6 possible sources. By programming register **CCIROTMD_X**, user can specify whether single channel (CCIR656/BT.1302), 2-channel TDM (@54/72 MHz), 4-channel TDM (@108/144 MHz) or HD video is to be output. When HD video is selected, luminance component is output through **oCCIRD_0** while chrominance component is output through **oCCIRD_1**.

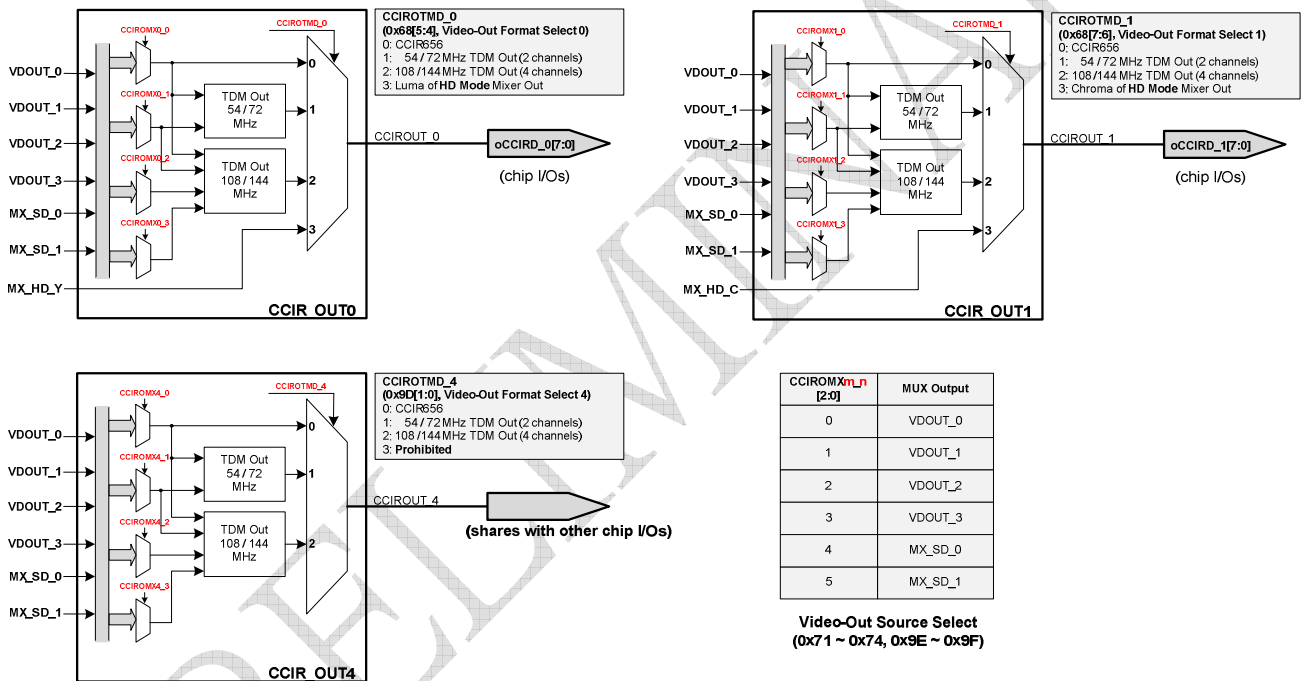

- <Note>**
 (1) VDOUT_0 ~ VDOUT_3 are from Video Decoder 0 ~ Video Decoder 3 respectively.
 MX_SD_0, MX_SD_1, MX_HD_C and MX_HD_C are from the video mixer.
 (2) MX_HD_Y and MX_HD_C are valid only when (OUT_SEL=4dB).

Data Path of Chip-Level Video Output Unit

CCIROUT_0 and **CCIROUT_1** have dedicated chip I/O pins (oCCIRD_0 and oCCIRD_1 respectively), while **CCIROUT_4** has to share I/O pins with others. To use **CCIROUT_4**, please set **CCIROPINOPT** as '1' and refer to the following table.

I/O Pin Number	I/O Pin Name	CCIROUT_4 Bus
116	ACLKP	CCIROUT_4[7]
117	ASYNP	CCIROUT_4[6]
118	ADATP	CCIROUT_4[5]
119	IRQ/ALINKI	CCIROUT_4[4]
122	ALINKO	CCIROUT_4[3]
124	MPP4	CCIROUT_4[2]
125	MPP3	CCIROUT_4[1]
127	MPP1	CCIROUT_4[0]

By setting **CCIRINPINOPT** as '1', user can use the pins listed above as TDM input pins. In that case **CCIROUT_4** is not available.

General Purpose Input /Output (GPIO)

The DM5886 supports GPIO function. The function only valid when REG70 [4]=0 and REG7A[6]=0. REG7A~REG7F are corresponding GPIO registers and MPP1~MPP4 (pin No.127~24) are corresponding pins. We separate GPIO function into GPI and GPO for description. GPO function is used to set the programmable pin high or low by register. GPI function is used to detect the input signal high, low, raising edge or falling edge and then output high level signal to interrupt pin(IRQ). GPI and GPO are described below.

GPO

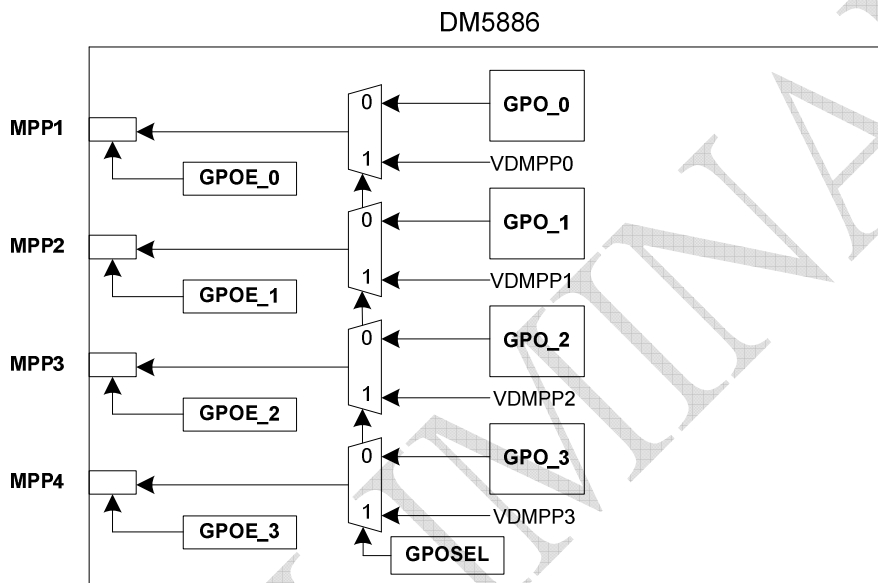

There are four GPO pin (MPP1~MPP4) in DM5886. The GPO function only valid when REG70[4]=0, REG7A[6]=0, **GPOSEL=0 (REG7A[7])** and **GPOE_X=1 (REG7C[7:4])**. Fig.x shows the GPO function.

Pin MPP1~MPP4 can be programmed by GPO_0~GPO_3 (REG7C[3:0]) through GPO function.

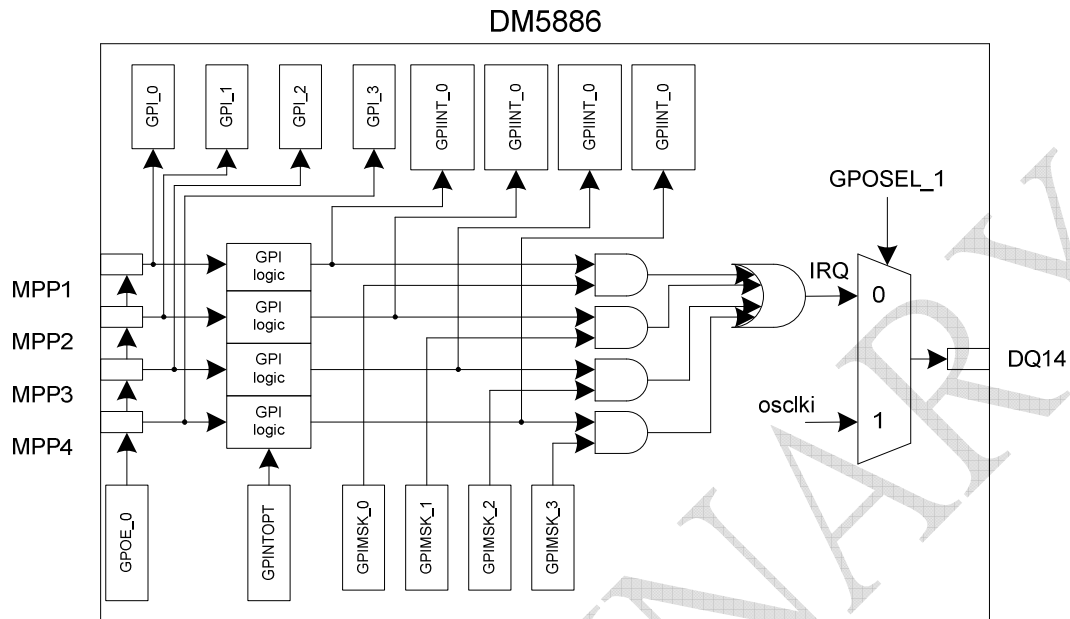
GPI

The DM5886 supports four GPI input pin and one IRQ output pin. Fig.x1 shows the GPI block diagram. The GPI function only valid when REG70[4]=0, REG7A[6]=0, **GPOE_X=0 (REG7C[7:4])** and **GPOSEL_1=0 (REG7A[4])**. The MPP1~MPP4 are the GPI input pin and DQ14 is the IRQ output pin. The GPI_0~GPI_3 are the read only status register. They show the GPI input from MPP1~MPP4 high or low. The GPIINT_0~GPIINT_3 are also read only status register. They show that GPI input MPP1~MPP4 high or low or raising edge or falling edge happened. The GPIINTOPT is the option to select GPI format from MPP1~MPP4 high or low or raising edge or falling edge. The GPIINTOPT table shows below. The GPIMSK_0~GPIMSK_3 are the mask signal for the corresponding GPI input.

GPINTOPT table

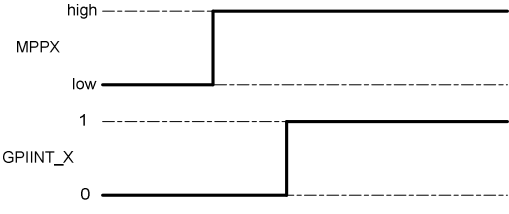
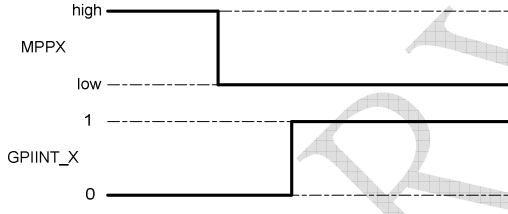
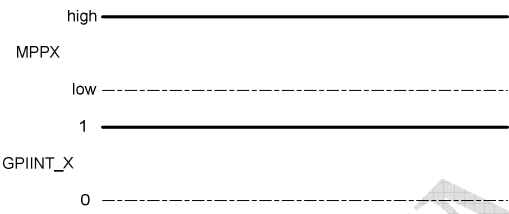
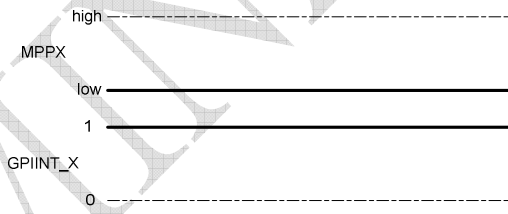
<p>GPINTOPT=2h0</p> <p>Raising edge trigger</p> 	<p>GPINTOPT=2h0</p> <p>falling edge trigger</p> 
<p>GPINTOPT=2h0</p> <p>High level trigger</p> 	<p>GPINTOPT=2h0</p> <p>Low level trigger</p> 

Internal Control Registers

System Control

Address= 8'h64

System Control Page							
7-bit	6-bit	5-bit	4-bit	3-bit	2-bit	1-bit	0-bit
0	0	0	0	0	0	0	1
				PAGE_3	PAGE_2	PAGE_1	PAGE_0

PAGE_0: VD space 0, to access VD_0 register please program this bit to 1.

PAGE_1: VD space 1, to access VD_1 register please program this bit to 1.

PAGE_2: VD space 2, to access VD_2 register please program this bit to 1.

PAGE_3: VD space 3, to access VD_3 register please program this bit to 1.

In case of register read, only one of the four bits can be set to 1.

Address= 8'h65

System Reset							
7-bit	6-bit	5-bit	4-bit	3-bit	2-bit	1-bit	0-bit
0	0	0	0	0	0	0	0
						RSTZ	TRSTZ

TRSTZ: When 1, reset whole chip except SW PLL, GPIO and Device ID setting. (WO)

RSTZ: When 1, reset all video decoders, mixer, TDM and audio interface. It also resets video decoder configurations.

Address= 8'h66

Global INT Mask							
7-bit	6-bit	5-bit	4-bit	3-bit	2-bit	1-bit	0-bit
0	0	0	0	0	0	0	0
				VDMAS K_3	VDMAS K_2	VDMAS K_1	VDMAS K_0

VDMASK_0: Enable INT from VD_0.

VDMASK_1: Enable INT from VD_1.

VDMASK_2: Enable INT from VD_2.

VDMASK_3: Enable INT from VD_3.

Address= 8'h67

Global INT Status							
7-bit	6-bit	5-bit	4-bit	3-bit	2-bit	1-bit	0-bit
0	0	0	0	0	0	0	0
				VDINT_3	VDINT_2	VDINT_1	VDINT_0

VDINT_0: VD_0 INT status. (RO)

VDINT_1: VD_1 INT status. (RO)

VDINT_2: VD_2 INT status. (RO)

VDINT_3: VD_3 INT status. (RO)

Address= 8'h68

CCIR656 IO Control							
7-bit	6-bit	5-bit	4-bit	3-bit	2-bit	1-bit	0-bit
2'h0		2'h0		0	0	0	0
CCIROTMD_1		CCIROTMD_0		CCIROE_3	CCIROE_2	CCIROE_1	CCIROE_0

CCIROE_0: Chip CCIR656_0 related 9 pins output enable.
When 1, output mode. When 0, input mode.

CCIROE_1: Chip CCIR656_1 related 9 pins output enable.
When 1, output mode. When 0, input mode.

CCIROE_2: Chip CCIR656_2 related 9 pins output enable.
When 1, output mode. When 0, input mode.

CCIROE_3: Chip CCIR656_3 related 9 pins output enable.
When 1, output mode. When 0, input mode.

CCIROTMD_0: Chip CCUROUT_0 output Mode type.

2'h0: CCIR656 output mode.

2'h1: 54/72Mhz TDM mode with D1 resolution for each channel.

2'h2: 108/144Mhz TDM mode with D1 resolution for each channel.

2'h3: HD Mixer mode with **Y** data bus.

CCIROTMD_1: Chip CCUROUT_1 output Mode type.

2'h0: CCIR656 output mode.

2'h1: 54/72Mhz TDM mode with D1 resolution for each channel.

2'h2: 108/144Mhz TDM mode with D1 resolution for each channel.

2'h3: HD Mixer mode with **C** data bus.

Address= 8'h69

PIXCLK Polarity							
7-bit	6-bit	5-bit	4-bit	3-bit	2-bit	1-bit	0-bit
0	0	0	0	0	0	0	0
OPIXCLK3_INV	OPIXCLK2_INV	OPIXCLK1_INV	OPIXCLK0_INV	OPIXCLK4_INV		IPIXCLK_INV	

IPIXCLK_INV: When 1, inverse iTDM pixclk to internal logic.

OPIXCLK4_INV: When 1, inverse output pixclk of CCIROUT_4.

OPIXCLK0_INV: When 1, inverse output pixclk of CCIROUT_0.

OPIXCLK1_INV: When 1, inverse output pixclk of CCIROUT_1.

OPIXCLK2_INV: When 1, inverse output pixclk of CCIROUT_2.

OPIXCLK3_INV: When 1, inverse output pixclk of CCIROUT_3.

Address= 8'h6A

IC Mode Control							
7-bit	6-bit	5-bit	4-bit	3-bit	2-bit	1-bit	0-bit
0	0	0	0	2'h2		2'h0	
				PINCFG		CLKADCOPT	

CLKADCOPT: The VADC_1 input clock selection. (144Mhz for 960H, 108MHz for 720H)

2'h0: The default value, sources from PLL1.

2'h1: Clock sources from PLL2.

2'h2: Clock source from chip pin NO.126.

PINCFG: IC pin mode option.

Set 2'h0 for 720 Video decoder x4.

Set 2'h1 for 720 Video decoder x4 and Mixer.

Set 2'h2 for 960 Video decoder x4.

Set 2'h3 for 960 Video decoder x4 + Mixer

Address= 8'h6B

Output Pixclk Delay Configuration							
7-bit	6-bit	5-bit	4-bit	3-bit	2-bit	1-bit	0-bit
0	3'h0			0	3'h0		
	DLYMUX_PIXCLK1				DLYMUX_PIXCLK0		

DYLMUX_PIXCLK0: Programmable pixclk delay of CCIROUT_0.

(3'h0: zero delay → 3'h7: max delay, add 0.6ns at every step)

DYLMUX_PIXCLK1: Programmable pixclk delay of CCIROUT_1.

(3'h0: zero delay → 3'h7: max delay, add 0.6ns at every step)

Address= 8'h6C

VD Power Down							
7-bit	6-bit	5-bit	4-bit	3-bit	2-bit	1-bit	0-bit
0	0	0	0	0	0	0	0
				VDPWD N_3	VDPWD N_2	VDPWD N_1	VDPWD N_0

VDPWDN_0: When 1, VD 0 into power down mode.

VDPWDN_1: When 1, VD 1 into power down mode.

VDPWDN_2: When 1, VD 2 into power down mode.

VDPWDN_3: When 1, VD 3 into power down mode.

Address= 8'h6D

VD Power On Rstz							
7-bit	6-bit	5-bit	4-bit	3-bit	2-bit	1-bit	0-bit
0	0	0	0	0	0	0	0
			VMPRST	VDPRST	VDPRST	VDPRST	VDPRST
			T	3	2	1	0

VDPRST0: Write 1, reset VD 0.

VDPRST1: Write 1, reset VD 1.

VDPRST2: Write 1, reset VD 2.

VDPRST3: Write 1, reset VD 3.

VMPRST0: Write 1, reset Mixer.

Address= 8'h6E

IP Test Mode							
7-bit	6-bit	5-bit	4-bit	3-bit	2-bit	1-bit	0-bit
0	0	0	0	0	0	0	0
VADCSEL			SW_VA	SW_VA	SW_PLL	SW_PLL	SW_MBI
			DCBYP	DCTSTE	BYPEN	TSTEN	SPATEN
			EN	N			

SW_MBISTPATEN: When 1, drive MBIST detail signal to chip IO pins.

SW_PLLTSTEN: When 1, drive PLL out clocks to chip IO pins.

SW_PLLBYPEN: When 1, bypass internal pll out source.

SW_VADCTSTEN: When 1, drive VADCSEL indicated ADC outputs to chip IO pins.

SW_VADCBYPEN: When 1, bypass VADCBYPOPT indicated ADC with chip input ADC signals.

VADC_SEL: valid for SW_VADCTSTEN

3'h0: VADC_doutA=VADC_dout1, VADC_doutB=VADC_dout2

3'h1: VADC_doutA=VADC_dout3, VADC_doutB=VADC_dout4

3'h2: VADC_doutA= VADCMX0_0 =>[VADC_dout1/VADC_dout2] mux

VADC_doutA= VADCMX0_1 =>[VADC_dout3/VADC_dout4] mux

3'h3: will drive VADC_0 analog IP Do [15:1], selected signal to [VADC_doutA, VADC_doutB]

3'h4: will drive VADC_1 analog IP Do [15:1], selected signal to [VADC_doutA, VADC_doutB]

Address= 8'h6F

MBIST Status							
7-bit	6-bit	5-bit	4-bit	3-bit	2-bit	1-bit	0-bit
0	0	0	0	0	0	0	0
BISTGO	MBDONE		MBERR_4	MBERR_3	MBERR_2	MBERR_1	MBERR_0

MBERR_0: When 1, memory of group 0 has error, Set by HW, write 1 to clear.

MBERR_1: When 1, memory of group 1 has error, Set by HW, write 1 to clear.

MBERR_2: When 1, memory of group 2 has error, Set by HW, write 1 to clear.

MBERR_3: When 1, memory of group 3 has error, Set by HW, write 1 to clear.

MBERR_4: When 1, memory of group 4 has error, Set by HW, write 1 to clear.

MBDONE: MBIST has finished self test, Set by HW, write 1 to clear.

BISTGO: Write 1 to start MBIST logic. HW auto clear this bit after MBIST done.

Address= 8'h70

ITDM Control							
7-bit	6-bit	5-bit	4-bit	3-bit	2-bit	1-bit	0-bit
0	0	0	0	0	0	0	0
		CCIRITMD			CCIROP INOPT	CCIRINP INOPT	CCIRINE N

CCIRINEN: When 1, enable ITDM function.

CCIRINPINOPT: ITDM data and clk bus selected option.

When 1, Data Bus[7:0] → Pin No. [116~119,122,124,125,127]

Clk pin → Pin No. 126

When 0, Data Bus[7:0] → Pin No. [85~88,90~93]

Clk pin → Pin No. 54

CCIROPINOPT: CCIROUT_4 output

When set 1, enable CCIR656_4 bus as output.

CCIRITMD: Video source from iTDM mode selected.

2'b00: CCIR656 .

2'b01: 72/54 TDM digital signal.

2'b1x: 144/108 TDM digital signal.

Address= 8'h71

CCIROUT_0 Otdm Configuration 1							
7-bit	6-bit	5-bit	4-bit	3-bit	2-bit	1-bit	0-bit
0	3'h1			0	3'h0		
	CCIROMX0_1				CCIROMX0_0		

CCIROMX0_0: The mux of CCIROUT_0's channel 0 at OTDM mode.

CCIROMX0_1: The mux of CCIROUT_0's channel 1 at OTDM mode.

Address= 8'h72

CCIROUT_0 Otdm Configuration 2							
7-bit	6-bit	5-bit	4-bit	3-bit	2-bit	1-bit	0-bit
0	3'h3			0	3'h2		
	CCIROMX0_3				CCIROMX0_2		

CCIROMX0_2: The mux of CCIROUT_0's channel 2 at OTDM mode.

CCIROMX0_3: The mux of CCIROUT_0's channel 3 at OTDM mode.

Address= 8'h73

CCIROUT_1 Otdm Configuration 1							
7-bit	6-bit	5-bit	4-bit	3-bit	2-bit	1-bit	0-bit
0	3'h1			0	3'h0		
	CCIROMX1_1				CCIROMX1_0		

CCIROMX1_0: The mux of CCIROUT_1's channel 0 at OTDM mode.

CCIROMX1_1: The mux of CCIROUT_1's channel 1 at OTDM mode.

Address= 8'h74

CCIROUT_1 Otdm Configuration 2							
7-bit	6-bit	5-bit	4-bit	3-bit	2-bit	1-bit	0-bit
0	3'h3			0	3'h2		
	CCIROMX1_3				CCIROMX1_2		

CCIROMX1_2: The mux of CCIROUT_1's channel 2 at OTDM mode.

CCIROMX1_3: The mux of CCIROUT_1's channel 3 at OTDM mode.

Address= 8'h75

IO/Clock Configuration							
7-bit	6-bit	5-bit	4-bit	3-bit	2-bit	1-bit	0-bit
0	0	0	0	0	0	0	0
		VMCLKSEL			ACLKP OE	ALINKO E	IRQOE

IRQOE: If using DQ14 as IRQ, set this bit as '1'

Otherwise, this bit is "don't care"

ALINKOE: If audio data is to be sent to next stage using audio cascade mode, set as '1'.

Otherwise, set as '0'

ACLKPOE: Set as '1' when I2S playback is to be enabled.

VMCLKSEL: Clock selection for video mixer.

2'h0: Mixer clock sources from internal PLL (PLL1). (Normal operation)

2'h1: Mixer clock sources from PLL1 with frequency divided by 2.

2'h2: Mixer clock sources from external pin No.126.

2'h3: Mixer clock sources from external pin No.126 with frequency divided by 2.

Address= 8'h77

CHIP Status							
7-bit	6-bit	5-bit	4-bit	3-bit	2-bit	1-bit	0-bit
0	0	0	0	0	0	0	0
							PWRON

PWRON: Power On status. (RO)

Address= 8'h78

I2C Master Configuration							
7-bit	6-bit	5-bit	4-bit	3-bit	2-bit	1-bit	0-bit
8'hB8							
CH device address							

CH0~CH3: i2c slave device address. (R/W)

- DM5886 device address will be {4'hC,4'h0}
- I2CMaster_0: device address will be {4'hC,4'h2}
- I2CMaster_1: device address will be {4'hC,4'h4}
- I2CMaster_2: device address will be {4'hC,4'h6}
- I2CMaster_3: device address will be {4'hC,4'h8}
- For broadcast I2CMaster_CH0~I2CMaster_CH3, device address {4'HC,4'HE}

Address= 8'h79

I2CM status							
7-bit	6-bit	5-bit	4-bit	3-bit	2-bit	1-bit	0-bit
0	0	2'h0		0	0	0	0
	MI2CRD CMD	MI2CSEL		CHNAC K3	CHNAC K2	CHNAC K1	CHNAC K0

CHNACK0: CH0 I2C fail (RO, WC) .

CHNACK1: CH1 I2C fail (RO, WC) .

CHNACK2: CH2 I2C fail (RO, WC) .

CHNACK3: CH3 I2C fail (RO, WC) .

MI2CSEL: The device address is 0xCA and select which channel will be set.

-I2CMaster_CH0: device address will be {4'hC 4'ha} & {MI2CSEL=2'b00}.

-I2CMaster_CH1: device address will be {4'hC 4'ha} & {MI2CSEL=2'b01}.

-I2CMaster_CH2: device address will be {4'hC 4'ha} & {MI2CSEL=2'b10}.

-I2CMaster_CH3: device address will be {4'hC 4'ha} & {MI2CSEL=2'b11}.

MI2CRDCMD: When 1, the MI2C restart command enable.

Address= 8'h7A

GPO Mode							
7-bit	6-bit	5-bit	4-bit	3-bit	2-bit	1-bit	0-bit
0	0	0	0	0	0	0	0
GPOSE L	MI2CEN	MCLKO PT	GPOSE L_1				

GPOSEL_1: Set 1, pin No.63 output osclki signal

Set 0, pin No.63 output IRQ function

MCLKOPT: When 1, fast master I2C clock speed.

MI2CEN: When 1, enable master I2C interface. (R/W)

GPOSEL: Set 1, pin MPP1 (pin No.127), MPP2 (pin No.126), MPP3(pin No.125), MPP4 (pin No.124) select VDMPP signal

Set 0, pin MPP1 (pin No.127), MPP2 (pin No.126), MPP3(pin No.125), MPP4 (pin No.124) select GPO signal

Address= 8'h7C

GPIO							
7-bit	6-bit	5-bit	4-bit	3-bit	2-bit	1-bit	0-bit
0	0	0	0	0	0	0	0
GPOE_3	GPOE_2	GPOE_1	GPOE_0	GPO_3	GPO_2	GPO_1	GPO_0

GPOE_0: GPO_0 output enable

GPOE_1: GPO_1 output enable

GPOE_2: GPO_2 output enable

GPOE_3: GPO_3 output enable

GPO_0: GPOSEL = 0 and GPOE_0=1 Set 0 MPP1 output low, set 1 output high.

GPO_1: GPOSEL = 0 and GPOE_1=1 Set 0 MPP2 output low, set 1 output high.

GPO_2: GPOSEL = 0 and GPOE_2=1 Set 0 MPP3 output low, set 1 output high.

GPO_3: GPOSEL = 0 and GPOE_3=1 Set 0 MPP4 output low, set 1 output high.

Address= 8'h7D

GPIO							
7-bit	6-bit	5-bit	4-bit	3-bit	2-bit	1-bit	0-bit
0	0	0	0	0	0	0	0
		GPINTOPT		GPIMSK _3	GPIMSK _2	GPIMSK _1	GPIMSK _0

GPIMSK_0: GPI mask.

GPIMSK_1: GPI mask.

GPIMSK_2: GPI mask.

GPIMSK_3: GPI mask.

GPINTOPT: GPI interrupt option

Address= 8'h7E

GPIO							
7-bit	6-bit	5-bit	4-bit	3-bit	2-bit	1-bit	0-bit
0	0	0	0	0	0	0	0
GPI_3	GPI_2	GPI_1	GPI_0	GPIINT_ 3	GPIINT_ 2	GPIINT_ 1	GPIINT_ 0

GPIINT_0: RO. GPI interrupt status register

GPI_0: RO. GPI status register

Address= 8'h7F

SW FAST SWITCH							
7-bit	6-bit	5-bit	4-bit	3-bit	2-bit	1-bit	0-bit
0	0	0	0	0	0	0	0
			OFASTSW_OPT	OFASTSW_SEL3	OFASTSW_SEL2	OFASTSW_SEL1	OFASTSW_SEL0

OFASTW_SEL0: valid when VD0 REG04[4]=1 and OFASTSW_OPT=1

set 0, select VIN1A as VD0 CVBS source

set 1, select VIN1B as VD0 CVBS source

OFASTW_SEL1: valid when VD1 REG04[4]=1 and OFASTSW_OPT=1

set 0, select VIN2A as VD1 CVBS source

set 1, select VIN2B as VD1 CVBS source

OFASTW_SEL2: valid when VD2 REG04[4]=1 and OFASTSW_OPT=1

set 0, select VIN3A as VD2 CVBS source

set 1, select VIN3B as VD2 CVBS source

OFASTW_SEL3: valid when VD3 REG04[4]=1 and OFASTSW_OPT=1

set 0, select VIN4A as VD3 CVBS source

set 1, select VIN4B as VD3 CVBS source

OFASTSW_OPT: valid when REG04[4]=1

Set 0, VD0-VD3 SW FASTSW control signal from OFASTSW_SEL0-OFASTSW_SEL3

Set 1, VD0-VD3 SW FASTSW control signal from input pin MPP0~MPP3

Video ADC
Address= 8'h80

Video ADC 0 Configuration 1							
7-bit	6-bit	5-bit	4-bit	3-bit	2-bit	1-bit	0-bit
0	0	0	0	0	0	0	0
	SW_sel_2		SW_sel_1		SWGAIN_0	pd_v2	pd_v1

pd_v1: Power down VIN1A & VIN1B, active high.

pd_v2: Power down VIN2A & VIN2B, active high.

SWGAIN_0: Software programs VADC 0's gain setting, active high. When low, the VADC 0' gain setting programmed by Hardware auto.

SW_sel_1: Software select active CVBS input. (0: VIN1A, 1: VIN1B)

SW_sel_2: Software select active CVBS input. (0: VIN2A, 1: VIN2B)

Address= 8'h81

Video ADC 0 Configuration 2							
7-bit	6-bit	5-bit	4-bit	3-bit	2-bit	1-bit	0-bit
4'hA				0	0	0	0
bias_vadc12				SvideoC_2B	SvideoC_2A	SvideoC_1B	SvideoC_1A

bias_vadc12: VADC 0's bias setting.

SvideoC_1A: Channel VIN1A chroma clamping. When 1, the analog clamping level is set to 50% for chroma signal processing.

SvideoC_1B: Channel VIN1B chroma clamping. When 1, the analog clamping level is set to 50% for chroma signal processing.

SvideoC_2A: Channel VIN2A chroma clamping. When 1, the analog clamping level is set to 50% for chroma signal processing.

SvideoC_2B: Channel VIN2B chroma clamping. When 1, the analog clamping level is set to 50% for chroma signal processing.

Address= 8'h82

Video ADC 0 Configuration 3							
7-bit	6-bit	5-bit	4-bit	3-bit	2-bit	1-bit	0-bit
0	0	0	0	0	0	0	0
SW_gain1B				SW_gain1A			

SW_gain1A: VIN1A's gain value, valid when REG80[2]=1.

SW_gain1B: VIN1B's gain value, valid when REG80[2]=1.

Ps. Minimum gain is set by 4'h0. Maximum gain is set by 4'hf.

The characteristic is the same as REG83

Address= 8'h83

Video ADC 0 Configuration 4							
7-bit	6-bit	5-bit	4-bit	3-bit	2-bit	1-bit	0-bit
0	0	0	0	0	0	0	0
SW_gain2B				SW_gain2A			

SW_gain2A: VIN2A's gain value, valid when REG80[2]=1.

SW_gain2B: VIN2B's gain value, valid when REG80[2]=1.

Address= 8'h84

Video ADC 0 Configuration 5							
7-bit	6-bit	5-bit	4-bit	3-bit	2-bit	1-bit	0-bit
0	0	0	0	0	0	0	0
clmp1B				clmp1A			

Clmp1A: VIN1A's clamp value.

Clmp1B: VIN1B's clamp value.

The clamp can be used to adjust the sync tip value to the nominal value of 20.

Address= 8'h85

Video ADC 0 Configuration 6							
7-bit	6-bit	5-bit	4-bit	3-bit	2-bit	1-bit	0-bit
0	0	0	0	0	0	0	0
Clmp2B				clmp2A			

Clmp2A: VIN2A's clamp value.

Clmp2B: VIN2B's clamp value.

Address= 8'h86

Video ADC 1 Configuration 1							
7-bit	6-bit	5-bit	4-bit	3-bit	2-bit	1-bit	0-bit
0	0	0	0	0	0	0	0
	SW_sel_4		SW_sel_3		SWGAIN_1	pd_v4	pd_v3

pd_v3: Power down VIN3A & VIN3B, active high.

pd_v4: Power down VIN3A & VIN3B, active high.

SWGAIN_1: Software programs VADC 1's gain setting, active high. When low, the VADC 1' gain setting programmed by Hardware auto.

SW_sel_3: Software select active CVBS input. (0: VIN3A, 1: VIN3B)

SW_sel_4: Software select active CVBS input. (0: VIN4A, 1: VIN4B)

Address= 8'h87

Video ADC 1 Configuration 2							
7-bit	6-bit	5-bit	4-bit	3-bit	2-bit	1-bit	0-bit
4'hA				0	0	0	0
bias_vadc34				SvideoC_4B	SvideoC_4A	SvideoC_3B	SvideoC_3A

bias_vadc34: VADC 1's bias setting.

SvideoC_3A: Channel VIN3A chroma clamping. When 1, the analog clamping level is set to 50% for chroma signal processing.

SvideoC_3B: Channel VIN3B chroma clamping. When 1, the analog clamping level is set to 50% for chroma signal processing.

SvideoC_4A: Channel VIN4A chroma clamping. When 1, the analog clamping level is set to 50% for chroma signal processing.

SvideoC_4B: Channel VIN4B chroma clamping. When 1, the analog clamping level is set to 50% for chroma signal processing.

Address= 8'h88

Video ADC 1 Configuration 3							
7-bit	6-bit	5-bit	4-bit	3-bit	2-bit	1-bit	0-bit
0	0	0	0	0	0	0	0
SW_gain3B				SW_gain3A			

SW_gain3A: VIN3A's gain value, valid when REG86[2]=1.

SW_gain3B: VIN3B's gain value, valid when REG86[2]=1.

Address= 8'h89

Video ADC 1 Configuration 4							
7-bit	6-bit	5-bit	4-bit	3-bit	2-bit	1-bit	0-bit
0	0	0	0	0	0	0	0
SW_gain4B				SW_gain4A			

SW_gain4A: VIN4A's gain value, valid when REG86[2]=1.

SW_gain4B: VIN4B's gain value, valid when REG86[2]=1.

Address= 8'h8A

Video ADC 1 Configuration 5							
7-bit	6-bit	5-bit	4-bit	3-bit	2-bit	1-bit	0-bit
0	0	0	0	0	0	0	0
Clmp3B				Clmp3A			

Clmp3A: VIN3A's clamp value.

Clmp3B: VIN3B's clamp value.

Address= 8'h8B

Video ADC 1 Configuration 6							
7-bit	6-bit	5-bit	4-bit	3-bit	2-bit	1-bit	0-bit
0	0	0	0	0	0	0	0
Clmp4B				Clmp4A			

Clmp4A: VIN4A's clamp value.

Clmp4B: VIN4B's clamp value.

Address= 8'h8C

Video ADC LPF Option							
7-bit	6-bit	5-bit	4-bit	3-bit	2-bit	1-bit	0-bit
0	0	0	0	2'h0		2'h0	
				lpf_34		lpf_12	

lpf_12: VADC 0 LPF selected.

lpf_34: VADC 1 LPF selected.

lpf_xx: 2'h0: 6MHz

2'h1: 9MHz

Others: bypass

Address= 8'h8D

VADC Clk Delay Configuration 1							
7-bit	6-bit	5-bit	4-bit	3-bit	2-bit	1-bit	0-bit
0	3'h0			0	3'h0		
	DLYMUX_ANA34				DLYMUX_ANA12		

DLYMUX_ANA12: Programmable delay of digcore aclk_out0 from aclk_0.

(3'h0: zero delay → 3'h7: max delay, add 0.6ns at every step)

DLYMUX_ANA34: Programmable delay of digcore aclk_out1 from aclk_1.

(3'h0: zero delay → 3'h7: max delay, add 0.6ns at every step)

Address= 8'h8E

VADC Clk Delay Configuration 2							
7-bit	6-bit	5-bit	4-bit	3-bit	2-bit	1-bit	0-bit
0	3'h0			0	3'h0		
DLYMUX_ANA72				DLYMUX_ANA36			

DLYMUX_ANA36: Programmable delay of digcore aclk36_out from aclk36.

(3'h0: zero delay → 3'h7: max delay, add 0.6ns at every step)

DLYMUX_ANA72: Programmable delay of digcore aclk72_out from aclk72.

(3'h0: zero delay → 3'h7: max delay, add 0.6ns at every step)

Address= 8'h8F

VADC Digcore Config							
7-bit	6-bit	5-bit	4-bit	3-bit	2-bit	1-bit	0-bit
0	0	0	0	0	3'h0		
					DLYMUX_VD		

DLYMUX_VD: Programmable delay of VD clk.

(3'h0: zero delay → 3'h7: max delay, add 0.6ns at every step)

PLL
Formula:

$$\text{CLK_OUT} = \text{XIN} * (\text{M}+2) / [(\text{N}+2) * \text{OD} * 2]$$

Where CLK_OUT: PLL output frequency

XIN: PLL input frequency.

M: The numerator of PLL formula.

[N, OD]: The denominator of PLL formula.

Attention:

1. 100MHz <= CLK_OUT * OD <= 250MHz
2. 1MHz <= XIN/(N+2) <= 25MHz
3. OD >= 1

Truth Table:

PD	BP	OE	CLK_OUT
0	0	0	CLK_OUT
0	0	0	XIN
Don't Care	1	0	XIN
Don't Care	Don't Care	1	0
Other			Undefined

PD: Power down control; Active high.

BP: Bypass XIN to CLK_OUT; Active high.

OE: CLK_OUT enable pin, Active low.

Address= 8'h90

SW PLL Control							
7-bit	6-bit	5-bit	4-bit	3-bit	2-bit	1-bit	0-bit
0	0	0	0	0	0	0	0
SWPLL RST						SWPLL2	SWPLL1

SWPLL1: set PLL1 input configuration from SWPLL1_XX set, otherwise hard wired with chip default vale. (144MHz)

SWPLL2: set PLL2 input configuration from SWPLL2_XX set, otherwise hard wired with chip default vale. (74.25MHz)

SWPLL RST: set 1, chip will enter a reset mode waiting for PLL stable in 1ms. After that, SW needs to re-program all register setting except PLL configuration.

Address= 8'h91

SW PLL Config							
7-bit	6-bit	5-bit	4-bit	3-bit	2-bit	1-bit	0-bit
0	0	0	0	0	0	0	0
		SWPLL2_OE	SWPLL1_OE	SWPLL2_PD	SWPLL2_BP	SWPLL1_PD	SWPLL1_BP

SWPLL1_BP: PLL1_BP SW program source.

SWPLL1_PD: PLL1_PD SW program source.

SWPLL2_BP: PLL2_BP SW program source.

SWPLL2_PD: PLL2_PD SW program source.

SWPLL1_OE: PLL1_OE SW program source.

SWPLL2_OE: PLL2_OE SW program source.

Address= 8'h92

SWPLL1 M							
7-bit	6-bit	5-bit	4-bit	3-bit	2-bit	1-bit	0-bit
8'h0							
SWPLL1_M[7:0]							

SWPLL1_M: PLL1_M SW program source.

Address= 8'h93

SWPLL1_N							
7-bit	6-bit	5-bit	4-bit	3-bit	2-bit	1-bit	0-bit
0	0	0	5'h0				
SWPLL1_M[8]			SWPLL1_N				

SWPLL1_N: PLL1_N SW program source

Address= 8'h94

SWPLL2_M							
7-bit	6-bit	5-bit	4-bit	3-bit	2-bit	1-bit	0-bit
8'h0							
SWPLL2_M[7:0]							

SWPLL2_M: PLL2_M SW program source

Address= 8'h95

SWPLL2_N								
7-bit	6-bit	5-bit	4-bit	3-bit	2-bit	1-bit	0-bit	
0	0	0	5'h0					
SWPLL2_M[8]			SWPLL2_N					

SWPLL2_N: PLL2_N SW program source

Address= 8'h96

SWPLL_OD							
7-bit	6-bit	5-bit	4-bit	3-bit	2-bit	1-bit	0-bit
4'h0				4'h0			
SWPLL2_OD				SWPLL1_OD			

SWPLL1_OD: PLL1_OD SW program source

SWPLL2_OD: PLL2_OD SW program source

DM5886 PLL SETTINGS Ref: 27MHz						
Ref: 27MHz	M	N	OD	PD	OE	BP
144 MHz	62	4	1	0	0	0
108 MHz	14	0	1	0	0	0
74.25 MHz	20	0	2	0	0	0

DM5886 PLL SETTINGS Ref: 36MHz						
Ref: 36MHz	M	N	OD	PD	OE	BP
144 MHz	14	0	1	0	0	0
108 MHz	10	0	1	0	0	0
74.25 MHz	64	6	2	0	0	0

Address= 8'h9D

CCIROUT_4 Output Control							
7-bit	6-bit	5-bit	4-bit	3-bit	2-bit	1-bit	0-bit
0	3'h0			0	0	2'h0	
	DLYMUX_PIXCLK4					CCIROTMD_4	

DYLMUX_PIXCLK4: Programmable pixclk delay of CCIR656_4.

(3'h0: zero delay → 3'h7: max delay, add 0.6ns at every step)

CCIROTMD_4: Chip CCIROUT_4 output Mode type.

2'h0: CCIR656 output mode.

2'h1: 54/72Mhz TDM mode with D1 resolution for each channel.

2'h2: 108/144Mhz TDM mode with D1 resolution for each channel.

Address= 8'h9E

CCIROUT_4 Otdm Configuration 1							
7-bit	6-bit	5-bit	4-bit	3-bit	2-bit	1-bit	0-bit
0	3'h0			0	3'h0		
	CCIROMX4_1				CCIROMX4_0		

CCIROMX4_0: The mux of CCIR656_4's channel 0 at OTDM mode.

CCIROMX4_1: The mux of CCIR656_4's channel 1 at OTDM mode.

Address= 8'h9F

CCIROUT_4 Otdm Configuration 2							
7-bit	6-bit	5-bit	4-bit	3-bit	2-bit	1-bit	0-bit
0	3'h0			0	3'h0		
	CCIROMX4_3				CCIROMX4_2		

CCIROMX4_2: The mux of CCIR656_4's channel 0 at OTDM mode.

CCIROMX4_3: The mux of CCIR656_4's channel 2 at OTDM mode.

Audio ADC/DAC

Address= 8'hF0

Audio ADC/DAC Test Mode							
7-bit	6-bit	5-bit	4-bit	3-bit	2-bit	1-bit	0-bit
0	0	0	0	0	0	0	0
	ADAC_mute	ADAC_r eset	ADAC_p d		AADC_t est	AADC_r eset	

AADC_reset: Audio ADC reset. (R/W: Active high)

AADC_test: Audio ADC test pin.

ADAC_pd: Audio DAC power down. (R/W: Active high)

ADAC_reset: Audio DAC reset. (R/W: Active high)

ADAC_mute: Audio DAC mute. (R/W: Active high)

Address= 8'hF1

Audio DAGC Config 1							
7-bit	6-bit	5-bit	4-bit	3-bit	2-bit	1-bit	0-bit
4'h0				4'h0			
AADC_DAGC_2				AADC_DAGC_1			

AADC_DAGC_1: Audio ADC 1 digital gain control.

AADC_DAGC_2: Audio ADC 2 digital gain control.

ADAC_DAGC_X[3:0], MIXGAIN_X[3:0]					
Set	Real Gain	dB	Set	Real Gain	dB
4'h0	0	-	4'h8	1.00	0
4'h1	0.125	-18.06	4'h9	1.25	1.94
4'h2	0.25	-12.04	4'hA	1.5	3.52
4'h3	0.375	-8.52	4'hB	1.75	4.86
4'h4	0.5	-6.02	4'hC	2.00	6.02
4'h5	0.625	-4.08	4'hD	2.25	7.04
4'h6	0.75	-2.50	4'hE	2.50	7.96
4'h7	0.875	-1.16	4'hF	2.75	8.79

Address= 8'hF2

Audio DAGC Configuration 2							
7-bit	6-bit	5-bit	4-bit	3-bit	2-bit	1-bit	0-bit
4'h0				4'h0			
AADC_DAGC_4				AADC_DAGC_3			

AADC_DAGC_3: Audio ADC 3 digital gain control.

AADC_DAGC_4: Audio ADC 4 digital gain control.

Address= 8'hF3

Audio DAGC Configuration 3							
7-bit	6-bit	5-bit	4-bit	3-bit	2-bit	1-bit	0-bit
4'h0				4'h0			
AADC_DAGC_P				AADC_DAGC_5			

AADC_DAGC_5: Audio ADC 5 digital gain control.

AADC_DAGC_P: Audio ADC digital gain control, source is selected from REGF8: ADAC_SRC .

Address= 8'hF4

Audio ADC Format							
7-bit	6-bit	5-bit	4-bit	3-bit	2-bit	1-bit	0-bit
0	0	0	0	2'h0		0	0
			AADC_MULCH	AADC_FSRATE		AADC_I2SMODE	

AADC_I2SMODE: (Digital I2S/DSP record interface): (master only)

1'b0: I2S mode

1'b1: DSP mode

AADC_FSRATE: (Digital I2S/DSP record interface)

2'b00: 48KHz

2'b01: 24KHz

2'b10: 16KHz

2'b11: 8KHz

AADC_MULCH: When 1, out 5 channels in record path.

When 0, out 2 channels in record path.

Address= 8'hF5

MIX Gain Configuration 1							
7-bit	6-bit	5-bit	4-bit	3-bit	2-bit	1-bit	0-bit
4'h0				4'h0			
MIXGAIN_2				MIXGAIN_1			

MIXOUT =

$$\begin{aligned}
 & \text{AIN1} * \text{ADC_DAGC_1} * \text{MIXGAIN_1} + \text{AIN2} * \text{ADC_DAGC_2} * \text{MIXGAIN_2} + \\
 & \text{AIN3} * \text{ADC_DAGC_3} * \text{MIXGAIN_3} + \text{AIN4} * \text{ADC_DAGC_4} * \text{MIXGAIN_4} + \\
 & \text{AIN5} * \text{ADC_DAGC_5} * \text{MIXGAIN_5} + \text{ADATP} * \text{MIXGAIN_P}
 \end{aligned}$$

Address= 8'hF6

MIX Gain Configuration 2							
7-bit	6-bit	5-bit	4-bit	3-bit	2-bit	1-bit	0-bit
4'h0				4'h0			
MIXGAIN_4				MIXGAIN_3			

Refer to REG F5

Address= 8'hF7

MIX Gain Configuration 3							
7-bit	6-bit	5-bit	4-bit	3-bit	2-bit	1-bit	0-bit
4'h0				4'h0			
MIXGAIN_P				MIXGAIN_5			

Refer to REG F5

Address= 8'hF8

Audio DAC Format							
7-bit	6-bit	5-bit	4-bit	3-bit	2-bit	1-bit	0-bit
0	3'h0			0	0	0	0
ADAC_T IME	ADAC_SRC			ADAC_FSRATE		ADAC_I 2SMOD E	ADAC_P RCH

ADAC_PRCH: When ADAC selecting the playback input source and PLAY_PRCH=0, ADAC chooses the playback left channel. Otherwise use playback right channel.

ADAC_I2SMODE: (Digital I2S/DSP playback interface): (mater only).

1'b0: I2S mode

1'b1: DSP mode.

ADAC_FSRATE: (Digital I2S/DSP playback interface):

2'b00: 48KHz

2'b01: 24KHz

2'b10: 16KHz

2'b11: 8KHz

DAC_SRC:

3'h0: ADATP (playback)

3'h1: MIXOUT

3'h2: AIN_1

3'h3: AIN_2

3'h4: AIN_3

3'h5: AIN_4

3'h6: AIN_5

ADAC_TIME:

When 1, use ADAC_FSRATE, ADAC mode to generate ACLKP/ASYNP.

Otherwise share the same timing signals with ACLKR/ASYNR.

Address= 8'hF9

Audio ADC/DAC Test Mode							
7-bit	6-bit	5-bit	4-bit	3-bit	2-bit	1-bit	0-bit
0	0	0	0	0	0	0	0
			AADC_pd5	AADC_pd4	AADC_pd3	AADC_pd2	AADC_pd1

AADC_pdX: Power down of Audio ADC X, active high.

Address= 8'hFA

Audio ADC/DAC Bias							
7-bit	6-bit	5-bit	4-bit	3-bit	2-bit	1-bit	0-bit
4'h0				4'h0			
ADAC_bias				AADC_bias			

ADAC_bias: Audio DAC's bias setting.

AADC_bias: Audio ADC's bias setting.

Address= 8'hFB

Audio ADC/DAC Test Mode							
7-bit	6-bit	5-bit	4-bit	3-bit	2-bit	1-bit	0-bit
3'h0			0	0	0	2'h0	
AADCSEL			SW_AU DIOTST EN			VADCBYPOPT	

VADCBYPOPT: Video ADC bypass source option

2'b00: external A/B channel mode.

2'b01: external only A channel mode.

2'b10: external ADI mode.

SW_AUDIOTSTEN: When 1, chip enter to Audio Test mode, and drives Audio ADC/DAC test signal to I/O pins.

AADCSEL: Under Audio ADC test mode.

3'h0: AADC_1[15:0] selected to output pins.

3'h1: AADC_2[15:0] selected to output pins.

3'h2: AADC_3[15:0] selected to output pins.

3'h3: AADC_4[15:0] selected to output pins.

3'h4: AADC_5[15:0] selected to output pins.

Address= 8'hFC

Audio Cascade Mode Control							
7-bit	6-bit	5-bit	4-bit	3-bit	2-bit	1-bit	0-bit
2'h0		0	0	0	0	0	0
casID		SWCAS LVLO	SWCASI D	MIXCAS EN	I2SRCA SEN	ACASIE N	ACASO EN

casID and **SWCASLVL0** are effective only if (**SWCASID**=1). In this case SW should program these two registers to indicate the cascade ID of current stage. Please refer to the table below. If (**SWCASID**=0), these two registers are “don’t care”.

ID of Current Stage	SWCASLVL0	casID[1:0]
0	1'b1	2'b00
1	1'b0	2'b00
2	1'b0	2'b01
3	1'b0	2'b10

SWCASID: 0: The cascade ID is determined by HW logic.

1: The cascade ID is determined by SW through registers **casID** & **SWCASLVL0**.

MIXCASEN: When set as 1 the analog audio input AIN5 will be included in the cascade operation (using ADATM).

I2SRCASEN: 0: Audio cascade operation is disabled.

1: Audio cascade operation is enabled.

ACASIEN: 0: Cascade input pin (ALINKI) is disabled.

1: Cascade input pin (ALINKI) is enabled.

ACASOEN: Output enable control of cascade output pin (ALINKO). Active High.

Address= 8'hFD

Audio Cascade Mode Control and Status							
7-bit	6-bit	5-bit	4-bit	3-bit	2-bit	1-bit	0-bit
1	0	0	0	0	0	2'h0	
FCLK14 4	I2SDAT AWIDTH		ACASID CHG	ACASA CT	ACASID VLD	ACASID	

FCLK144: Set as 0 when PLL is configured to output 108 MHz clock.

Set as 1 when PLL is configured to output 144 MHz clock.

I2SDATAWIDTH: 0: The I2S/DSP interface uses 16-bit data.

1: The I2S/DSP interface uses 8-bit data.

ACASIDCHG: (RO, Write One to Clear)

This flag is asserted when a change in **ACASID** is detected.

ACASACT: (RO)

This flag is asserted when audio cascade is in operation.

ACASIDVLD: (RO)

0: The value of the register **ACASID** is not valid.

1: The value of the register **ACASID** is valid.

ACASID: (RO) Indicate the cascade ID recognized by HW.

0: The ID of current stage is 1 or 0.

1: The ID of current stage is 2.

2: The ID of current stage is 3.

Address= 8'hFE

Mixed Audio Cascade & Audio Record 2							
7-bit	6-bit	5-bit	4-bit	3-bit	2-bit	1-bit	0-bit
0	0	0	0	0	0	0	0
ADATM OPT						ADATR 2EN	

ADATMOPT: Set this bit the same value as **MIXCASEN**.

ADATR_2EN: Set as 1 to enable audio record channel 2 (using MI2CD1)

Address= 8'hFF

REVNUM							
7-bit	6-bit	5-bit	4-bit	3-bit	2-bit	1-bit	0-bit
8'h65							
REVNUM							

Video Decoder

HSYNC signal:

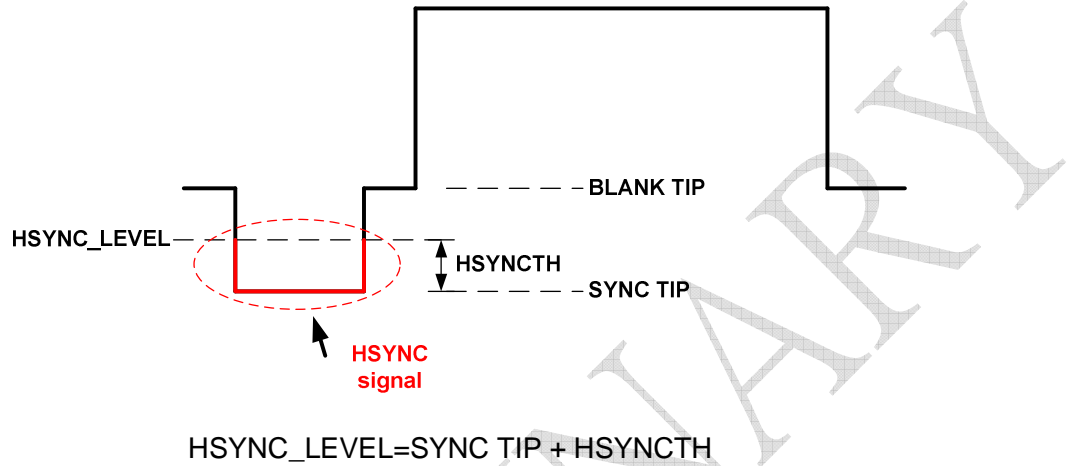

Address= 8'h00

VD Control							
7-bit	6-bit	5-bit	4-bit	3-bit	2-bit	1-bit	0-bit
0	0	0	0	1	0	1	0
BBRSTZ	IFLDFA STSW	FASTSWEN	S_Video	ADC_A	ADI_AD C	EN	SRSTZ

SRSTZ: SW reset video decoder, WO

EN: Enable Video decoding function

S_Video: input signal is S-Video

FASTSWEN: Enable fast switch function

IFLDFASTSW: Set 1 : Fast switch boundary at every field end. Only Valid when REG04[3] : 1'b0.

Set 0: Fast switch boundary at frame end.

BBRSTZ: BB reset only, WO

Address= 8'h01

WATCHSEL							
7-bit	6-bit	5-bit	4-bit	3-bit	2-bit	1-bit	0-bit
4'hf				0	0	2'b01	
AGC_LMT							

AGC_LMT: Analog AGC range

AGC

Address= 8'h02

AGC							
7-bit	6-bit	5-bit	4-bit	3-bit	2-bit	1-bit	0-bit
4'h0				1	0	1	1
AGC_gain					AGC_DT RACKE N	HWAGC EN	SYNCC AGCEN

SYNCCAGCEN: Set 1, enable CAGC gain update.

HWAGCEN: Hardware AGC enable

AGC_DTRACKEN: Dynamic sync tip tracking enable

AGC_gain: SW set AGC gain, RW

Address= 8'h03

AGCDOWN_TH							
7-bit	6-bit	5-bit	4-bit	3-bit	2-bit	1-bit	0-bit
8'h63							
AGCDOWNTH[7:0]							

AGCDOWNTH: ADC couldn't larger than 867, if it is, will decrease the agc_gain.

Address= 8'h04

AGCDOWN_TH							
7-bit	6-bit	5-bit	4-bit	3-bit	2-bit	1-bit	0-bit
0	0	0	1	0	0	2'h3	
FASTSWOPT				OFASTSW		AGCDOWNTH[9:8]	

OFASTSW: Set 1: FASTSW control from input PIN(MPOUT).

Set 0: FASTSW source from internal logic related to FASTSWOPT, RW

FASTSWOPT: Set fast switch frame length ((FASTSWOPT+1)x8), RW

Video Detection Misc

Address= 8'h05

HSYNCTH							
7-bit	6-bit	5-bit	4-bit	3-bit	2-bit	1-bit	0-bit
8'h30							
HSYNCTH							

HSYNCTH: Set horizontal sync threshold level

Address= 8'h06

Vdet_misc							
7-bit	6-bit	5-bit	4-bit	3-bit	2-bit	1-bit	0-bit
0	0	0	0	1	0	1	1
MONOUT	MUKSEL			BLACKOUT	SETUP_7.5IRE	OCCIREN	ColorPOUT

ColorPOUT: Set 1, VD will drive Color panel when no video signal detected, otherwise drive black panel. Color panel setting see 0x2A[6:4]

OCCIREN: Set 1, VD will out CCIR656

SETUP_7.5IRE: Set 1, add 7.5 IRE to the BLANK_TIP

BLACKOUT: Set 1, VD will drive black panel or blue panel when no video signal detected.

MONOUT:force CCIR656 Cb=128, Cr=128

Color Killer

Address= 8'h08

ColorKill TH							
7-bit	6-bit	5-bit	4-bit	3-bit	2-bit	1-bit	0-bit
8'h20							
CBDIFFTH[7:0]							

CBDIFFTH: Set the color burst difference threshold

2D Comb Filter

Address= 8'h09

Com2D_CFG							
7-bit	6-bit	5-bit	4-bit	3-bit	2-bit	1-bit	0-bit
0	0	0	0	0	0	0	0
			FORCE_MONO		FORCE_VCOMB	NOTCH_FLTSEL	DIS_VCOMB

DIS_VCOMB: Set 1 to disable vertical comb filter

NOTCHFLTSEL: Set 0, use the wide band notchfilter

Set 1, use the narrow band notchfilter

FORCE_MONO: Set 1 to force the MONO signal mode.

Address= 8'h0C

PAL SW CFG							
7-bit	6-bit	5-bit	4-bit	3-bit	2-bit	1-bit	0-bit
2'h0		0					0
Y_SHARP_GAIN							PALSW OPT

PALSWOPT: Set 1 to use standard pal switch define to demodulation.

For line lock camera, set this bit to 1.

Y_SHARP_GAIN:

2'h0 : no sharpness function

2'h1: sharpness gain 0.5

2'h2: sharpness gain 1

2'h3: sharpness gain 2

Address= 8'h10

VD Decoder status							
7-bit	6-bit	5-bit	4-bit	3-bit	2-bit	1-bit	0-bit
0	0	0	0	0	0	0	0
PAL_Nc	PAL-I,B,B1,G,H,D/ PAL_N	PAL_M	PAL_60	NTSC-443	NTSC-J/NTSC-M	COLOR KILL_52 5	COLOR KILL_62 5

The register show the video decoded status

RO. Set 1 to enable SW force mode.

Address= 8'h11

VD_STS							
7-bit	6-bit	5-bit	4-bit	3-bit	2-bit	1-bit	0-bit
0	0	0	0	0	0	0	0
CLKLOCK_STST							DET_NONILT

DET_NONILT: RO. Detect the non-interlaced signal format.

CLKLOCK_STST: RO. Clock offset lock status

Address= 8'h12

DAGC_LMT							
7-bit	6-bit	5-bit	4-bit	3-bit	2-bit	1-bit	0-bit
4'h3				4'hf			
CLKOFF_LOCK				DAGC_LMT			

DAGC_LMT: Digital AGC range

CLKOFF_LOCK: Clock offset locking function. 4'h0: always tracking

Others: clock offset lock within CLKOFF_LOCK * 8 ppm.

Address= 8'h13

VD_CFG							
7-bit	6-bit	5-bit	4-bit	3-bit	2-bit	1-bit	0-bit
0	1	1	0	1	0	0	1
SWFAR_54MD	HWFAR_54OPT	GAINLOCK_OPT	CLKOFFDIS	CBADJ	BLANK_SHIFTE_N	ALINEL_OCK	CLKOFF_TRACKEN

CLKOFF_TRACKEN: CLKOFFSET tracking enable

ALINELOCK: active line lock option, fixed line start position.

BLANK_SHIFTEN: set 1, blank level will be modified according to color burst mean value per line.

CBADJ: Color burst adjust

CLKOFFDIS: Disable clock offset tracking function

GAINLOCK_OPT: Enable gain locking function after 16 frame decoded.

HWFAR54OPT: Set 1, FAR4FS will operate in 54Mhz when detecting 4.43 subcarrier

SWFAR54MD: Software force FAR4FS operate in 54Mhz.

Address= 8'h14

VD_CFG							
7-bit	6-bit	5-bit	4-bit	3-bit	2-bit	1-bit	0-bit
0	0	0	0	0	1	0	1
		LLCFASTMD			VDETOP T	LTRACK OPT	CLKLO CKOPT

CLKLOCKOPT: Set 0 : Always tracking clock offset when
 $\text{abs}(\text{clkoffset}) > \text{CLKOFF_LOCK} (\text{REG12}[7:4])$
 Set 1 : keep tracking until first time
 $\text{abs}(\text{clkoffset}) < \text{CLKOFF_LOCK}(\text{REG12}[7:4])$

LTRACKOPT: Set 1: Hardware continues active line (video) decoding when miss valid HSYNC signal until video loss.
 Set 0: Hardware performs active line (video) decoding until valid HSYNC signal detected.

VDETOPT: Set 1: using rising edge of HSYNC signal as line detection timing.
 Set0: using falling edge of HSYNC signal as line detection timing.
 For long cable application, set this bit to 1.

LLCFASTMD[1:0]:
 Line lock Auto Detection stable period. Valid when $\text{REG3B}[5]=1$.

Set 0: check line lock mode right after decode started

Set 1: check line lock mode after 8 frames decoded.

Set 2, 3: check line lock mode after 16 frames decoded.

Address= 8'h15

CLKOFF_CTL							
7-bit	6-bit	5-bit	4-bit	3-bit	2-bit	1-bit	0-bit
0	0	0	0	1	1	0	0
					CLKFRACEN	FIXHSYNC_MD L	SWFIXCLOCKOFF

SWFIXCLOCKOFF: Set 1, SW fixed clock offset. Force clock offset value=

{REG25[4:0],REG24[7:0],REG23[7:0]}.

FIXHSYNC_MD L: Set 1, fixed the HSYNC_LEVEL to be REG05 HSYNCTH.

CLKFRACEN: Set 1, enable fraction clock offset tracking.

Address= 8'h17

CTI gain							
7-bit	6-bit	5-bit	4-bit	3-bit	2-bit	1-bit	0-bit
0	0	6'd10					
HMIDTR ACK							

HMIDTRACK: Set 1: tracking BLANK TIP each line at Front Porch Blanking position (REG4B[7:0]).

Set 0: tracking BLANK TIP at CVBS serration period.

Address= 8'h18

LOWTRACK							
7-bit	6-bit	5-bit	4-bit	3-bit	2-bit	1-bit	0-bit
0	0	0	0	0	0	0	0
FSHYBC OPT	DISCOL KILL		NONINT EN	CAGCO PT	TRHSYN COPT	LOWTR ACK	TRHSYN CTH

TRHSYNCTH: Set 1: enable HW auto update HSYNCTH during video detection.

Set 0: use fix HSYNCTH (REG05[7:0]) during video detection.

LOWTRACK: Set 1: tracking SYNC TIP per line(s) from LOWLEVEL TRACKER.

Set 0: tracking SYNC TIP at CVBS serration period.

TRHSYNCOPT: Set 1: use fix HSYNCTH (REG05) during video detection

Set 0: enable HW auto update HSYNCTH during video detection.

CAGCOPT: Set 1 to enable color AGC.

NONINTEN: Set 1 to enable auto detect non-interlaced singal.

DISCOLKILL: Set 1 to disable auto detect color kill mode

FSHYBCOPT: ONLY valid under FASTSWEN.

Set 1: Keep previous tracked HSYNCTH

Set 0: use REG05 as HSYNCTH

Address= 8'h20

AGC gain							
7-bit	6-bit	5-bit	4-bit	3-bit	2-bit	1-bit	0-bit
0	0	0	0	0	0	0	0
DAGC Gain				AAGC Gain			

AAGC Gain: Analog AGC gain setting, RO

DAGC Gain: Digital AGC gain setting, RO

Address= 8'h21

AGC gain							
7-bit	6-bit	5-bit	4-bit	3-bit	2-bit	1-bit	0-bit
0	0	0	0	0	0	0	0
SYNC_TIP[7:0]							

SYNC_TIP: RO

Address= 8'h22

AGC gain							
7-bit	6-bit	5-bit	4-bit	3-bit	2-bit	1-bit	0-bit
0	0	0	0	0	0	0	0
BLANK_TIP[7:0]							

BLANK_TIP: RO

Address= 8'h23

7-bit	6-bit	5-bit	4-bit	3-bit	2-bit	1-bit	0-bit
0	0	0	0	0	0	0	0
CLKOFF[7:0]							

CLKOFF: RO, internal 2's compliment clock offset tracking status. Unit (ppm)

Address= 8'h24

7-bit	6-bit	5-bit	4-bit	3-bit	2-bit	1-bit	0-bit
0	0	0	0	0	0	0	0
CLKOFF[15:8]							

CLKOFF: RO, internal 2's compliment clock offset tracking status. Unit (ppm)

Address= 8'h25

7-bit	6-bit	5-bit	4-bit	3-bit	2-bit	1-bit	0-bit
0	0	0	0	0	0	0	0
				SYNC_TIP[20:16]			

SYNC_TIP: RO

Address= 8'h26

Blue Panel Select							
7-bit	6-bit	5-bit	4-bit	3-bit	2-bit	1-bit	0-bit
0	0	0	0	0	0	0	0
				BLANK_TIP[9:8]		SYNC_TIP[9:8]	

BLANK_TIP: RO

SYNC_TIP: RO

Address= 8'h29

Blue Panel Select							
7-bit	6-bit	5-bit	4-bit	3-bit	2-bit	1-bit	0-bit
0	0	0	0	0	0	0	0
						PALBLP ANL	NTSCBL PANL

PALBLPANL: Valid when REG06[3]=1. When no signal, SW sets PAL blue panel out.

NTSCBLPANL: Valid when REG06[3]=1. When no signal, SW sets NTSC blue panel out.

When PALBPANL=0, NTSCBLPANL=0. HW takes PAL as default mode.

Address= 8'h2A

VD_MISC							
7-bit	6-bit	5-bit	4-bit	3-bit	2-bit	1-bit	0-bit
0	0	0	0	0	0	2'h2	
	ColorOut					MPP_OPT	

MPP_OPT: (Enable when GPOSEL (REG7A[7]) = 1'b1)

2'h0: drive field info to pin.

2'h1: drive Active info to pin.

2'h2: drive NOVID info to pin.

2'h3: drive FASTSW_SEL info to pin.

VD_MPP signal pin out:

(VD0,VD1,VD2,VD3)→(MI2CD0, MI2CD1, MI2CD2, MI2CD3)

ColorOut: valid when REG06[3]=1 and REG06[0]=1.

3'h0: blue panel

3'h1: red panel

3'h2: white panel

3'h3: green panel

3'h4: magenta panel

3'h7: color rotation mode, blue → red →

white → green → magenta → black → blue...

Color Process

Address= 8'h2B

COLOR_EXT							
7-bit	6-bit	5-bit	4-bit	3-bit	2-bit	1-bit	0-bit
0	0	2'h1		0	0	0	1
	CCIRBL ANKOP T					NTSC_C CIREXT	EXT_CO LOR

EXT_COLOR: Set 1, Y/Cb/Cr value from 8'h1~8'hfe

NTSC_CCIREXT: Set 1 in NTSC mode, CCIR656 output 487 active line.

CCIRBLANKOPT: Set 1: output blanking period close to standard CCIR656.

Set 0: with short V blank lines before active field start.

Address= 8'h2C

Hue							
7-bit	6-bit	5-bit	4-bit	3-bit	2-bit	1-bit	0-bit
8'h0							
Hue[7:0]							

Hue: Hue[9:0] = {REG33[1:0],REG2C[7:0]}

10'h0~10'h3ff → 0~360 degree

Address= 8'h2D

Saturation							
7-bit	6-bit	5-bit	4-bit	3-bit	2-bit	1-bit	0-bit
8'h10							
Saturation							

Saturation: unsigned, Range : 0 ~ 15.9375

8'hff : maximum, about x16 color intensity.

8'h00: (no color)

Address= 8'h2E

Contrast							
7-bit	6-bit	5-bit	4-bit	3-bit	2-bit	1-bit	0-bit
8'h80							
Contrast							

Contrast: unsigned, Range : 0~2

8'hff: maximum (x2) contrast

8'h80: original signal (x1)

8'h00: minimum contrast

Address= 8'h2F

Brightness							
7-bit	6-bit	5-bit	4-bit	3-bit	2-bit	1-bit	0-bit
8'h00							
Brightness							

Brightness: signed

8'h7f: brightest

8'h80: darkest

Address= 8'h30

INT Mask							
7-bit	6-bit	5-bit	4-bit	3-bit	2-bit	1-bit	0-bit
0	0	0	0	0	0	0	0
	MDCHG_1_MASK	VLOST_1_MASK	VDET_1_MASK		MDCHG_0_MASK	VLOST_0_MASK	VDET_0_MASK

VDET_0_MASK: Set 1, enable register 0x31 VDET_0 interrupt function, RW

VLOST_0_MASK: Set 1, enable register 0x31 VLOST_0 interrupt function, RW

MDCHG_0_MASK: Set 1 enable register 0x31 MDCHG_0 interrupt function, RW

VDET_1_MASK: Set 1 to enable register 0x31 VDET_1 interrupt function, RW

VLOST_1_MASK: Set 1 enable register 0x31 VLOST_1 interrupt function, RW

MDCHG_1_MASK: Set 1 enable register 0x31 MDCHG_1 interrupt function, RW

Address= 8'h31

INT status							
7-bit	6-bit	5-bit	4-bit	3-bit	2-bit	1-bit	0-bit
0	0	0	0	0	0	0	0
	MDCHG_1	VLOST_1	VDET_1		MDCHG_0	VLOST_0	VDET_0

VDET_0: when detect video signal, the interrupt set, set by HW, set 1 to clear

VLOST_0: when lose video signal, the interrupt set, set by HW, set 1 to clear

MDCHG_0: when detect video signal change, the interrupt set, set by HW, set 1 to clear

VDET_1: valid for fast switch mode channel B, when detect video signal, the interrupt set, set by HW, set 1 to clear

VLOST_1: valid for fast switch mode channel B, when lose video signal, the interrupt set, set by HW, set 1 to clear

MDCHG_1: valid for fast switch mode channel B, when detect video signal change format, the interrupt set, set by HW, set 1 to clear

Address= 8'h32

650 Mode							
7-bit	6-bit	5-bit	4-bit	3-bit	2-bit	1-bit	0-bit
0	0	0	0	0	0	0	1
						S960H	STVL65 0

S960H :Sony Effio mode

NTSC mode : 948x480 PAL mode: 936x576

STVL650: 960 Mode

When set 1 : NTSC mode 960x480, PAL mode 960x576

When set 0 : NTSC mode 720x480, PAL mode 720x576

Address= 8'h33

HUE							
7-bit	6-bit	5-bit	4-bit	3-bit	2-bit	1-bit	0-bit
0	0	0	0	0	0	0	0
						Hue[9:8]	

Hue: Hue[9:0] = {REG33[1:0],REG2C[7:0]}

10'h0~10'h3ff → 0~360 degree

Address= 8'h34

FIELD OPTION							
7-bit	6-bit	5-bit	4-bit	3-bit	2-bit	1-bit	0-bit
0	0	0	0	0	0	0	0
					FIELD_I NV	FIELD ONLY	

FIELD_ONLY: CCIR656 signal output field 0 only

FIELD_INV: Inverse output CCIR656 signal field

Address= 8'h35

Chroma Average							
7-bit	6-bit	5-bit	4-bit	3-bit	2-bit	1-bit	0-bit
0	0	0	0	0	0	0	1
						CAVNTS CMD	CAVPAL MD

CAVNTSCMD: Set 1, enable NTSC mode Cb/Cr line average.

Set 0, disable.

CAVPALMD: Set 1, enable PAL mode Cb/Cr line average.

Set 0, disable.

Address= 8'h36

MASK CCIR656 LINE							
7-bit	6-bit	5-bit	4-bit	3-bit	2-bit	1-bit	0-bit
0	0	0	0	0	0	0	1
						MASKA LL	PAL_M SK3

PAL_MSK3: Set 1, it will mask field 0 and 1 last lines according to REG37

MASKALL: mask all active

Address= 8'h37

MASK LINE							
7-bit	6-bit	5-bit	4-bit	3-bit	2-bit	1-bit	0-bit
0	3'h3			0	3'h3		
	MSK_LINE_F1				MSK_LINE_F0		

MSK_LINE_F0: When REG36[0] = 1, Mask Field 0 last number of active lines (0-7)

MSK_LINE_F1: When REG36[0] = 1, Mask Field 1 last number of active lines (0-7)

Address= 8'h38

MONO TH							
7-bit	6-bit	5-bit	4-bit	3-bit	2-bit	1-bit	0-bit
1	0	0	5'd31				
MONO_EN			MONO_TH				

MONO_TH: MONO mode AGC threshold. AGC max value 30. when set MONO_TH 31.

AGC will always less than MONO_TH.

MONO_EN: Set 0, when no valid color burst detected.

Output CCIR656 Y through Notch filter.

Set 1, when no valid color burst detected. Output CCIR656

Y through Notch filter if $AGC_GAIN \geq MONO_TH$, otherwise output

CCIR656 Y with ADC data.

When No valid color burst detected (color kill mode). Output

CCIR656 Cb/Cr with 128 (no color).

Address= 8'h39

COLOR BURST DETECT							
7-bit	6-bit	5-bit	4-bit	3-bit	2-bit	1-bit	0-bit
0	3'h4			4'h5			
	COLBSTCYC			COLBTHSEL			

COLBTHSEL: Color Burst detection threshold.

4'h0: COLBSTH = 0.125*(BLANK TIP – SYNC TIP)

4'h1: COLBSTH = 0.25*(BLANK TIP – SYNC TIP)

4'h2: COLBSTH = 0.375*(BLANK TIP – SYNC TIP)

4'h3: COLBSTH = 0.5*(BLANK TIP – SYNC TIP)

4'h4: COLBSTH = 0.09375*(BLANK TIP – SYNC TIP)

4'h5: COLBSTH = 0.078125*(BLANK TIP – SYNC TIP)

4'h6: COLBSTH = 0.0625*(BLANK TIP – SYNC TIP)

4'h7: COLBSTH = 0.03125*(BLANK TIP – SYNC TIP)

4'h8: COLBSTH = 0

When color burst peak to peak value larger than COLBTHSEL, it's been considered a good color burst signal cycle.

COLBSTCYC: When COLBSTCYC numbers of valid color burst cycle detected, VD will decode video with color and Color AGC will optionally started. Otherwise will enter color kill mode.

Address= 8'h3A

CAGC							
7-bit	6-bit	5-bit	4-bit	3-bit	2-bit	1-bit	0-bit
1	0	0	0	0	0	0	0
CAGCEN	CAGCLOCKOPT	cagc_gain					

cagc_gain: RO. Chroma gain value. [5:2] integer, [1:0] fractional.

(max 15.75, min 1)

CAGCLOCKOPT: Set 1, enable color AGC tracking until CAGC gain stable.

Set 0, color AGC tracking for first 15 video decoded frames.

CAGCEN : Set 1, enable color AGC.

Address= 8'h3B

Line Lock Camera							
7-bit	6-bit	5-bit	4-bit	3-bit	2-bit	1-bit	0-bit
0	0	0	0	0	0	0	0
CAMLOCKOPT	LOCKCAM_DET	HLOCKDET1	ACTSHIFT				

ACTSHIFT: Active region shift, 2's compliment (-16~15)

HLOCKDET1: Set 1, to enable auto-detect Line Lock camera.

LOCKCAM_DET: RO, Line lock camera detected. (RO)

CAMLOCKOPT: Set 1, when line lock camera used.

Address= 8'h3C

LLOCKTH							
7-bit	6-bit	5-bit	4-bit	3-bit	2-bit	1-bit	0-bit
8'd20							
LLOCKTH							

LLOCKTH: Line Lock auto detection threshold, valid only when 0x3B[5]=1.

When REG13[1]=1, line boundary difference within a field larger than LLOCKTH, Line Lock Camera detected.

Note: when clock offset tracking unstable and REG13[1]=1, line boundary difference might be large within a field.

Address= 8'h3D

VD_CFG							
7-bit	6-bit	5-bit	4-bit	3-bit	2-bit	1-bit	0-bit
0	0	0	0	0	0	0	0
	ORSTO PT	OBFOV F	OBFUD F	LLFAR4 FSOPT1			LLFAR4 FSOPT

LLFAR4FSOPT: Set 1, decode video chroma without clock offset compensation.

Set 0, decode video chroma after clock offset compensation.

Set this bit to one for Line Lock Camera.

LLFAR4FSOPT1: Set 1, Auto adjust the active region related to clock offset.

When force line lock mode, set this bit to 1;

OBFUDF: RO. CCIR output buffer under flow.

OBFOVF: RO. CCIR output buffer over flow.

ORSTOPT: Set 1, Reset CCIR output buffer when output buffer overflow or underflow.

Address= 8'h3D

OUT BUFFER							
7-bit	6-bit	5-bit	4-bit	3-bit	2-bit	1-bit	0-bit
8'h1a							
OBFTH							

OBFTH: CCIR656 output buffer ready threshold.

Once CCIR656 output buffer count is larger than

OBFTH, starts output CCIR656 active region.

PS. CCIR656 output buffer max length is 48, set OBFTH around middle level of buffer length.

Address= 8'h40

CCIROUT TYP EN							
7-bit	6-bit	5-bit	4-bit	3-bit	2-bit	1-bit	0-bit
0	0	0	0	0	0	0	0
		H_SAV_ACT	CROPEN		FLDCHIDEN	EAVCHIDEN	SWCHIDEN

SWCHIDEN: Valid when REG00[5]=1(FASTSWEN). Add SW channel ID

in first 4 data of active line, valid at fast switch mode.(field/frame)

EAVCHIDEN: Valid when REG00[5]=1(FASTSWEN) Add channel ID in EAV[3:0] and SAV[3:0], valid at fast switch mode. (field/frame)

FLDCHIDEN: Valid when REG00[6:5]=2'h3 (**IFLDFASTSW**, FASTSWEN), output CVBS source A to field 0, output CVBS source B to field 1.

CROPEN: Video cropping function enable.

H_SAV_ACT: Set 1, HSYNC signal will include SAV data, otherwise HSYNC signal only at active region.

Address= 8'h41

Cropping Register							
7-bit	6-bit	5-bit	4-bit	3-bit	2-bit	1-bit	0-bit
2'h0		2'h3		2'h0		2'h0	
H_STR[9:8]		H_ACT[9:8]		V_STR[9:8]		V_ACT[9:8]	

H_STR[9:8]: It defined the number of pixels start after SAV.

H_ACT[9:8]: It defined the number of active region.

V_STR[9:8]: It defined VSYNC start after active region line.

V_ACT[9:8]: It defined the number of VSYNC during active region.

$H_STR + H_ACT < \text{total number of pixels per line.}$

$V_STR + V_ACT < \text{total number of lines per field.}$

Address= 8'h42

Cropping Register							
7-bit	6-bit	5-bit	4-bit	3-bit	2-bit	1-bit	0-bit
8'h0							
H_STR[7:0]							

Address= 8'h43

Cropping Register							
7-bit	6-bit	5-bit	4-bit	3-bit	2-bit	1-bit	0-bit
8'hC0							
H_ACT[7:0]							

Address= 8'h44

Cropping Register							
7-bit	6-bit	5-bit	4-bit	3-bit	2-bit	1-bit	0-bit
8'h0							
V_STR[7:0]							

Address= 8'h45

Cropping Register							
7-bit	6-bit	5-bit	4-bit	3-bit	2-bit	1-bit	0-bit
8'd240							
V_ACT[7:0]							

Address= 8'h46

Cb/Cr Slicer							
7-bit	6-bit	5-bit	4-bit	3-bit	2-bit	1-bit	0-bit
1					3'h2		
SLICER_EN					SLICER_RANGE		

SLICER_EN: CB/CR coring function enable.

SLICER_RANGE: Coring range (0 ~7). When $128 - \text{SLICER_RANGE} < (\text{CB/CR}) < 128 + \text{SLICER_RANGE}$, force the Chroma value to 128.

Address= 8'h4B

BLANK1TIP							
7-bit	6-bit	5-bit	4-bit	3-bit	2-bit	1-bit	0-bit
8'hdc							
BLANK1TIP							

BLANK1TIP: valid when REG17[7]. Line Blanking sample position.

Address= 8'h4C

HSYNLOWCYC							
7-bit	6-bit	5-bit	4-bit	3-bit	2-bit	1-bit	0-bit
0	7'd20						
HSYNLOWCYC							

HSYNLOWCYC: When low level (signal smaller than HSYNC LEVEL) signal exists over HSYNLOWCYC, it's considered as a HSYNC signal Candidate.

Address= 8'h4D

LMARG27							
7-bit	6-bit	5-bit	4-bit	3-bit	2-bit	1-bit	0-bit
8'h30							
LMARG27							

LMARG27: Sync signal detect margin after video detect.

Address= 8'h4E

MARG27							
7-bit	6-bit	5-bit	4-bit	3-bit	2-bit	1-bit	0-bit
8'h30							
MARG27							

MARG27: Sync signal detect margin before video detect.

Video Mixer
Address= 8'hA0

Mixer Configuration							
7-bit	6-bit	5-bit	4-bit	3-bit	2-bit	1-bit	0-bit
0	0	0	0	4'h0			
VMSLO PT	VDSLO PT	PALEXT	CCIRPR OG0	OUT_SEL_0			

OUT_SEL_0: Mixer configuration select table. Valid for both Mixer_0 and Mixer_1.

	4'h0	4'h1	4'h2	4'h3	4'h4	4'h5																		
SD Mode	<table border="1"> <tr><td>0</td><td>1</td></tr> <tr><td>2</td><td>3</td></tr> </table>	0	1	2	3	<table border="1"> <tr><td>0</td></tr> <tr><td>1</td></tr> </table>	0	1	<table border="1"> <tr><td>0</td></tr> <tr><td>1</td><td>2</td></tr> </table>	0	1	2	<table border="1"> <tr><td>1</td><td>0</td><td>3</td></tr> <tr><td></td><td>2</td><td></td></tr> </table>	1	0	3		2		<table border="1"> <tr><td>0</td></tr> </table>	0	<table border="1"> <tr><td>0</td><td>1</td></tr> </table>	0	1
0	1																							
2	3																							
0																								
1																								
0																								
1	2																							
1	0	3																						
	2																							
0																								
0	1																							
HD Mode	<table border="1"> <tr><td>0</td><td>1</td></tr> <tr><td>2</td><td>3</td></tr> </table>	0	1	2	3																			
0	1																							
2	3																							

CCIRPROG0: when 1, enable mixer output from interlaced to progressive format

PALEXT: Only valid when OUT_SEL_0 = 4'h8.

When 1. output PAL SMPTE 274M resolution from 1920x1080 to 1920x1152.

Otherwise, output PAL SMPTE 274M resolution to 1920x1080

VDSLOPT: when 1, enable auto reset mixer video capture interface while internal CVBS VD detecting signal loss.

VMSLOPT: when 1, enable auto rest mixer video capture interface while mixer video capture interface detecting invalid CCIR656 signal.

Address= 8'hA1

Mixer Out Enable							
7-bit	6-bit	5-bit	4-bit	3-bit	2-bit	1-bit	0-bit
0	0	0	0	0	0	0	0
						SOUT_EN1	SOUT_EN0

SOUT_EN0: Mixer 0 enable.

SOUT_EN1: Mixer 1 enable. Only valid when SD mixer out and OUTSEL_0 =4'h4 /4'h5.

Address= 8'hA2

Mixer Mode detect							
7-bit	6-bit	5-bit	4-bit	3-bit	2-bit	1-bit	0-bit
0	0	0	0	0	0	0	0
PALMD	MODECHG	MDCHGRST	SWFORCEMD				

SWFORCEMD: when 1, will disable Mixer auto mode PAL/NTSC detect function.
 (Output format depends on REGA2[7] by SW)

MDCHGRST: when 1, Mixer will auto reset if MODECHGE detected.

MODECHG: (RO) when 1 indicates the system change mode change from NTSC to PAL or from PAL to NTSC.

PALMD: when SWFORCEMD=0 (PALMD RO), PALMD is a status of Mixer PAL/NTSC auto detect result.

When SWFORCEMD=1 (PALMD RW), set PALMD to 0 force NTSC mode, set PALMD to 1 force PAL mode.

Address= 8'hA3

Mixer Output format Configuration							
7-bit	6-bit	5-bit	4-bit	3-bit	2-bit	1-bit	0-bit
0	0	0	0	0	0	0	0
			NTSC_C CIREXT _0			BLUEO UT	IN960H

IN960H: only valid when SD mixer output.

set 1 enable 960H mixer output resolution.

Otherwise, 720H mixer output resolution.

Only valid in SD mixer out

BLUEOUT: Set 1 mixer output blue panel when no valid signal. See REGD3~REGD5 for blue panel configuration.

NTSC_CCIREXT_0: valid under SD NTSC mode.

When 1. Mixer output 487 active line video.

Otherwise. Mixer output 480 active line video.

Address= 8'hA4

CCIR Input Line Length							
7-bit	6-bit	5-bit	4-bit	3-bit	2-bit	1-bit	0-bit
0	0	0	0	0	0	2'h2	
						CCIRINLEN[9:8]	

Address= 8'hA5

CCIR Input Line Length							
7-bit	6-bit	5-bit	4-bit	3-bit	2-bit	1-bit	0-bit
8'hD0							
CCIRINLEN[7:0]							

CCIRINLEN[9:0]: Mixer capture interface cropping length. For 720H video, it might be set to 720 or 704 or any multiple of 4. For 960H video, it might be set to 960 or 948 or any multiple of 4. default 720.

Address= 8'hA6

Mixer Output partition Config							
7-bit	6-bit	5-bit	4-bit	3-bit	2-bit	1-bit	0-bit
0	0	0	0	0	0	0	0
				CORVLD_3	CORVLD_2	CORVLD_1	CORVLD_0

CORVLD_0: set 1 to enable output partition 0 Left-Top coordinate(COR_X0,COR_Y0). valid OUTSEL_0 = 4'h0, 4'h1, 4'h2, 4'h3, 4'h4, 4'h5 and 4'h8

CORVLD_1: set 1 to enable output partition 1 Left-Top coordinate(COR_X1,COR_Y1). valid OUTSEL_0 = 4'h0, 4'h1, 4'h2, 4'h3, 4'h5 and 4'h8

CORVLD_2: set 1 to enable output partition 2 Left-Top coordinate(COR_X2,COR_Y2). valid OUTSEL_0 = 4'h0, 4'h2, 4'h3, and 4'h8

CORVLD_3: set 1 to enable output partition 3 Left-Top coordinate(COR_X3,COR_Y3). valid OUTSEL_0 = 4'h0, 4'h3 and 4'h8

Default value: SD mixer out → NTSC 720x480 and OUT_SEL_0 = 4'h0.

Please refer to the following figure.

COR_X0[9:0]: X coordinate of partition 0 Left-Top point.

Default value: 10'd0 (10'h0)

COR_Y0[9:0]: Y coordinate of partition 0 Left-Top point.

Default value: 10'd0 (10'h0)

COR_X1[9:0]: X coordinate of partition 1 Left-Top point.

Default value: 10'd360 (10'h168)

COR_Y1[9:0]: Y coordinate of partition 1 Left-Top point.

Default value: 10'd0 (10'h0)

COR_X2[9:0]: X coordinate of partition 2 Left-Top point.

Default value: 10'd0 (10'h0)

COR_Y2[9:0]: Y coordinate of partition 2 Left-Top point.

Default value: 10'd240 (10'hF0)

COR_X3[9:0]: X coordinate of partition 3 Left-Top point.

Default value: 10'd360 (10'h168)

COR_Y3[9:0]: Y coordinate of partition 3 Left-Top point.

Default value: 10'd240 (10'hF0)

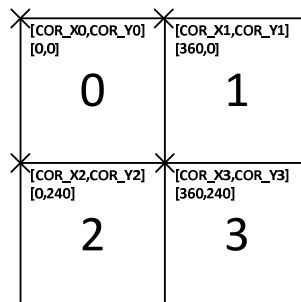

Address= 8'hA7

Mixer Output partition Coordinate							
7-bit	6-bit	5-bit	4-bit	3-bit	2-bit	1-bit	0-bit
2'h0		2'h1		2'h0		2'h0	
COR_Y1[9:8]		COR_X1[9:8]		COR_Y0[9:8]		COR_X0[9:8]	

Please refer to the figure in register 0xA6.

Address= 8'hA8

Mixer Output partition Coordinate							
7-bit	6-bit	5-bit	4-bit	3-bit	2-bit	1-bit	0-bit
8'h0							
COR_X0[7:0]							

Please refer to the figure in register 0xA6.

Address= 8'hA9

Mixer Output partition Coordinate							
7-bit	6-bit	5-bit	4-bit	3-bit	2-bit	1-bit	0-bit
8'h0							
COR_Y0[7:0]							

Please refer to the figure in register 0xA6.

Address= 8'hAA

Mixer Output partition Coordinate							
7-bit	6-bit	5-bit	4-bit	3-bit	2-bit	1-bit	0-bit
8'h68							
COR_X1[7:0]							

Please refer to the figure in register 0xA6.

Address= 8'hAB

Mixer Output partition Coordinate							
7-bit	6-bit	5-bit	4-bit	3-bit	2-bit	1-bit	0-bit
8'h0							
COR_Y1[7:0]							

Please refer to the figure in register 0xA6.

Address= 8'hAC

Mixer Output partition Coordinate							
7-bit	6-bit	5-bit	4-bit	3-bit	2-bit	1-bit	0-bit
2'h0		2'h1		2'h0		2'h0	
COR_Y3[9:8]		COR_X3[9:8]		COR_Y2[9:8]		COR_X2[9:8]	

Please refer to the figure in register 0xA6.

Address= 8'hAD

Mixer Output partition Coordinate							
7-bit	6-bit	5-bit	4-bit	3-bit	2-bit	1-bit	0-bit
8'h0							
COR_X2[7:0]							

Please refer to the figure in register 0xA6.

Address= 8'hAE

Mixer Output partition Coordinate							
7-bit	6-bit	5-bit	4-bit	3-bit	2-bit	1-bit	0-bit
8'hF0							
COR_Y2[7:0]							

Please refer to the figure in register 0xA6.

Address= 8'hAF

Mixer Output partition Coordinate							
7-bit	6-bit	5-bit	4-bit	3-bit	2-bit	1-bit	0-bit
8'h68							
COR_X3[7:0]							

Please refer to the figure in register 0xA6.

Address= 8'hB0

Mixer Output partition Coordinate							
7-bit	6-bit	5-bit	4-bit	3-bit	2-bit	1-bit	0-bit
8'hF0							
COR_Y3[7:0]							

Please refer to the figure in register 0xA6.

Address= 8'hB1

Mixer Output partition Coordinate							
7-bit	6-bit	5-bit	4-bit	3-bit	2-bit	1-bit	0-bit
0	3'h1			0	3'h2		
COR_YBR[10:8]				COR_XBR[10:8]			

COR_XBR[9:0]: X coordinate of partition 0 Bottom-Right point. Default 720.

COR_YBR[9:0]: Y coordinate of partition 0 Bottom-Right point. Default 480.

Address= 8'hB2

Mixer Out Region End Point Config 2							
7-bit	6-bit	5-bit	4-bit	3-bit	2-bit	1-bit	0-bit
8'hD0							
COR_XBR[7:0]							

Address= 8'hB3

Mixer Out Region End Point Config 3							
7-bit	6-bit	5-bit	4-bit	3-bit	2-bit	1-bit	0-bit
8'hE0							
COR_YBR[7:0]							

Address= 8'hB8

Mixer channel Enable							
7-bit	6-bit	5-bit	4-bit	3-bit	2-bit	1-bit	0-bit
0	0	0	0	0	0	0	0
SWVLDI N3	SWVLDI N2	SWVLDI N1	SWVLDI N0	CHEN3	CHEN2	CHEN1	CHEN0

According to OUTSEL_0, set related channel enable signal.

CHEN0: Set 1, channel 0 enable.

CHEN1: Set 1, Channel 1 enable.

CHEN2: Set 1, Channel 2 enable.

CHEN3: Set 1, Channel 3 enable.

SWVLDINX: Set 1, it will disable auto PAL/NTSC mode detect function in video capture interface X and bypass input CCIR656 signal to the mixer as valid signal.

Address= 8'hB9

Channel Select							
7-bit	6-bit	5-bit	4-bit	3-bit	2-bit	1-bit	0-bit
0	3'h1			0	3'h0		
	CHSEL_1				CHSEL_0		

CHSEL_0: select 1 out of 8 video sources for channel 0.

CHSEL_1: select 1 out of 8 video sources for channel 1.

Address= 8'hBA

Channel Select							
7-bit	6-bit	5-bit	4-bit	3-bit	2-bit	1-bit	0-bit
0	3'h3			0	3'h2		
	CHSEL_3				CHSEL_2		

CHSEL_2: select 1 out of 8 video sources for channel 2.

CHSEL_3: select 1 out of 8 video sources for channel 3.

CHSEL_X	3'h0	3'h1	3'h2	3'h3	3'h4	3'h5	3'h6	3'h7
MUXOUT	Analog CVBS0	Analog CVBS1	Analog CVBS2	Analog CVBS3	Digital ITDM CHID: 0	Digital ITDM CHID: 1	Digital ITDM CHID: 2	Digital ITDM CHID: 3

Address= 8'hBD

Mirror							
7-bit	6-bit	5-bit	4-bit	3-bit	2-bit	1-bit	0-bit
0	0	0	0	0	0	0	0
H_3_R	H_3_L	H_1_R	H_1_L	INV_H3	INV_H2	INV_H1	INV_H0

INV_H0: enable channel 0 mirror function. (Only valid in SD mode)

INV_H1: enable channel 1 mirror function. (Only valid in SD mode)

INV_H2: enable channel 2 mirror function. (Only valid in SD mode)

INV_H3: enable channel 3 mirror function. (Only valid in SD mode)

H_X_L: only valid in SD OUTSEL_0=4'h3 (H partition)

when 1. channel/partition X will crop original video Left 1/4 image.

H_X_R: only valid in SD OUTSEL_0=4'h3 (H partition)

when 1. channel/partition X will crop original video Right 1/4 image.

{H_X_R,H_X_L}=2'b1x, output Right 1/4 original image

=2'b01, output Left 1/4 original image

=2'b00, perform 1/4 horizontal downscaling from original image.

Address= 8'hBE

SW force Progressive Input format							
7-bit	6-bit	5-bit	4-bit	3-bit	2-bit	1-bit	0-bit
0	0	0	0	0	0	0	0
				SWPRGI N_3	SWPRGI N_2	SWPRGI N_1	SWPRGI N_0

SWPRGIN0: Take channel 0 video as progressive video, in spite of field flag.

SWPRGIN1: Take channel 1 video as progressive video, in spite of field flag.

SWPRGIN2: Take channel 2 video as progressive video, in spite of field flag.

SWPRGIN3: Take channel 3 video as progressive video, in spite of field flag.

Address= 8'hBF

SDRAM Burst Length Config							
7-bit	6-bit	5-bit	4-bit	3-bit	2-bit	1-bit	0-bit
0	0	0	0	0	0	0	0
				BRLEN OPT3	BRLEN OPT2	BRLEN OPT1	BRLEN OPT0

BRLENOP0: Channel 0 SDRAM burst length option.

BRLENOP1: Channel 1 SDRAM burst length option.

BRLENOP2: Channel 2 SDRAM burst length option.

BRLENOP3: Channel 3 SDRAM burst length option.

BRLENOPTX: When 1: SDRAM burst length = 1/2 of channel partition length

When 0: SDRAM burst length = 1/4 of channel partition length

If partition length is NOT a multiple of 4, set BRLENOPTX to 1.

Address= 8'hC0

Detected Valid Enable							
7-bit	6-bit	5-bit	4-bit	3-bit	2-bit	1-bit	0-bit
0	0	0	0	1	1	1	1
				WDOGE N_3	WDOGE N_2	WDOGE N_1	WDOGE N_0

WDOGEN_0: channel 0 capture interface watch dog enable.

WDOGEN_1: channel 1 capture interface watch dog enable.

WDOGEN_2: channel 2 capture interface watch dog enable.

WDOGEN_3: channel 3 capture interface watch dog enable.

When 1, enable channel watch dog counter. Watch dog counter will counts up until capture interface detect valid video. When watch dog counter reaches a certain of time (refer WDOGCNT_x), channel detection flag will be cleared (NOVID_x clear to 1)

Address= 8'hC1

Detected Valid Config 1							
7-bit	6-bit	5-bit	4-bit	3-bit	2-bit	1-bit	0-bit
4'h0				4'h0			
WDOGCNT_1				WDOGCNT_0			

WDOGCNT_0: channel 0 watch dog timer time out option.

WDOGCNT_1: channel 1 watch dog timer time out option.

When watch dog count over $(WDOGCNT_x+1) * 378ms$, watch dog counter time out asserted.

Address= 8'hC2

Detected Valid Config 2							
7-bit	6-bit	5-bit	4-bit	3-bit	2-bit	1-bit	0-bit
4'h0				4'h0			
WDOGCNT_3				WDOGCNT_2			

WDOGCNT_2: channel 2 watch dog timer time out option.

WDOGCNT_3: channel 3 watch dog timer time out option.

Address= 8'hC3

CCIRIN_0 CROP START							
7-bit	6-bit	5-bit	4-bit	3-bit	2-bit	1-bit	0-bit
0	0	0	5'h0				
			CROPLEN_0				

CROPLEN_0: channel 0 capture interface cropping start point.

Address= 8'hC4

CCIRIN_1 CROP START								
7-bit	6-bit	5-bit	4-bit	3-bit	2-bit	1-bit	0-bit	
0	0	0	5'h0					
			CROPLEN_1					

CROPLEN_1: channel 1 capture interface cropping start point.

Address= 8'hC5

CCIRIN_2 CROP START								
7-bit	6-bit	5-bit	4-bit	3-bit	2-bit	1-bit	0-bit	
0	0	0	5'h0					
			CROPLEN_2					

CROPLEN_2: channel 2 capture interface cropping start point.

Address= 8'hC6

CCIRIN_3 CROP START								
7-bit	6-bit	5-bit	4-bit	3-bit	2-bit	1-bit	0-bit	
0	0	0	5'h0					
			CROPLEN_3					

CROPLEN_3: channel 3 capture interface cropping start point.

Address= 8'hC8

Mixer Channel Status							
7-bit	6-bit	5-bit	4-bit	3-bit	2-bit	1-bit	0-bit
				1	1	1	1
				NOVID_3	NOVID_2	NOVID_1	NOVID_0

NOVID_0: 0 indicates valid channel 0 video detected. (RO)

NOVID_1: 0 indicates valid channel 1 video detected. (RO)

NOVID_2: 0 indicates valid channel 2 video detected. (RO)

NOVID_3: 0 indicates valid channel 3 video detected. (RO)

Address= 8'hCB

Capture Interface 0 Status							
7-bit	6-bit	5-bit	4-bit	3-bit	2-bit	1-bit	0-bit
0	0	0	0	0	0	0	0
				L525_D ET_0	L625_D ET_0	H720_D ET_0	H960_D ET_0

RO.

H960_DET_X: 1 indicates 960H video detected. (RO)

H720_DET_X: 1 indicates 720H video detected. (RO)

L625_DET_X: 1 indicates PAL (625 line) video detected. (RO)

L525_DET_X: 1 indicates NTSC (525 line) video detected. (RO)

Address= 8'hCC

Capture Interface 1 Status							
7-bit	6-bit	5-bit	4-bit	3-bit	2-bit	1-bit	0-bit
0	0	0	0	0	0	0	0
				L525_D ET_1	L625_D ET_1	H720_D ET_1	H960_D ET_1

RO.

Address= 8'hCD

Capture Interface 2 Status							
7-bit	6-bit	5-bit	4-bit	3-bit	2-bit	1-bit	0-bit
0	0	0	0	0	0	0	0
				L525_D ET_2	L625_D ET_2	H720_D ET_2	H960_D ET_2

RO.

Address= 8'hCE

Capture Interface 3 Status							
7-bit	6-bit	5-bit	4-bit	3-bit	2-bit	1-bit	0-bit
0	0	0	0	0	0	0	0
				L525_D ET_3	L625_D ET_3	H720_D ET_3	H960_D ET_3

RO.

Address= 8'hCF

SDRAM CLK Option							
7-bit	6-bit	5-bit	4-bit	3-bit	2-bit	1-bit	0-bit
0	0	0	0	4'h0			
SDRCLKINV				DLYMUX_SDRCLK			

DLYMUX_SDRCLK: Adjust the SDRAM clk delay timing.

Please refer to the following table for the delay time.

DLYMUX SDRCLK	4'h0	4'h1	4'h2	4'h3	4'h4	4'h5	4'h6	4'h7
Delay Time(ns)	0	0.35	1.01	1.39	2.03	2.38	3.09	3.42
DLYMUX SDRCLK	4'h8	4'h9	4'hA	4'hB	4'hC	4'hD	4'hE	4'hF
Delay Time(ns)	4.07	4.44	5.07	5.42	6.09	6.43	7.04	7.34

SDRCLKINV: Set 1, inverse the SDRAM clk for adjusted timing.

Address= 8'hD0

SDRAM Config 0							
7-bit	6-bit	5-bit	4-bit	3-bit	2-bit	1-bit	0-bit
8'h0							
MODEREG[7:0]							

Address= 8'hD1

SDRAM Config 1							
7-bit	6-bit	5-bit	4-bit	3-bit	2-bit	1-bit	0-bit
3'h0				5'h0			
COLSIZEOPT				MODEREG[12:8]			

MODEREG: The setting of Mode Register for SDRAM.

MODEREG	12	11	10	9	8	7	6	5	4	3	2	1	0
Function	RFU*			WBL	Test Mode		CAS Latency		BT	Burst Length			

*Note: RFU(Reserved for future use) should stay "0" during MRS cycle.

Burst Length: MODEREG[2:0]

This table specifies the data length of column access using the MODEREG[2:0] and selects the Burst Length to be 1, 2, 4, 8, or full page.

Burst Length	2	1	0
1	0	0	0
2	0	0	1
4	0	1	0
8	0	1	1
Reserved	1	0	0
Reserved	1	0	1
Reserved	1	1	0
Full Page	1	1	1

BT(Burst Type): MODEREG[3]

Burst Type can be one of two modes, Interleave Mode or Sequential Mode.

0: Sequential, 1: Interleave.

CAS Latency: MODEREG[6:4]

This table specifies the number of clock cycles from the assertion of the Read command to the first read data.

CAS Latency	6	5	4
Reserved	0	0	0
Reserved	0	0	1

2 clocks	0	1	0
3 clocks	0	1	1
Reserved	1	X	X

Test Mode: MODEREG[8:7]

These two bits must be programmed to 2'h0 in normal operation.

WBL(Write Burst Length): MODEREG[9]

This bit is used to select the write burst mode.

WBL	Write Burst Mode
0	Burst-Read-Burst-Write
1	Burst-Read-Single-Write

COLSIZEOPT: Set the SDRAM size (64MB or 128MB).

3'b000: Reserved for future use

3'b001: Reserved for future use

3'b010: 16bit, 128MB

3'b1xx: 16bit, 64MB

Recommend settings:

	64MB	128MB
CSR settings	REGD0: 8'h37 REGD1: 8'hE0	REGD0: 8'h37 REGD1: 8'h40

Address= 8'hD2

SDRAM Config 2							
7-bit	6-bit	5-bit	4-bit	3-bit	2-bit	1-bit	0-bit
0	0	0	0	0	0	0	0
SDRCL KZOPT	SDRWIN IOPT	RWGOO D	SDRTST RDY	SDR32M D	SDRTST	AUTOP RECHA RGEOP T	SELFRE SH

AUTOPRECHARGEOPT: SDRAM auto pre-charge.

SDRTST: SDRAM self-test enable.

SDRTSTRDY: (RO), In SDRAM self test mode, 1: Test ready, 0: Test still not ready.

RWGOOD: (RO), In SDRAM self test mode, 1: Good, 0: No Good

SDRCLKZOPT: SDRAM operated option. (Set 1 when at HD mode)

Address= 8'hD3

Blue Panel Y Config							
7-bit	6-bit	5-bit	4-bit	3-bit	2-bit	1-bit	0-bit
8'h29							
NOVID_Y_REG							

Blue Panel: Luminance(Y) value, default Blue color

Address= 8'hD4

Blue Panel CB Config							
7-bit	6-bit	5-bit	4-bit	3-bit	2-bit	1-bit	0-bit
8'hF0							
NOVID_CB_REG							

Blue Panel: Chrominance (Cb) value, default Blue color

Address= 8'hD5

Blue Panel CR Config							
7-bit	6-bit	5-bit	4-bit	3-bit	2-bit	1-bit	0-bit
8'h6E							
NOVID_CR_REG							

Blue Panel: Chrominance (Cr) value, default Blue color

Address= 8'hD6

Split Line Y							
7-bit	6-bit	5-bit	4-bit	3-bit	2-bit	1-bit	0-bit
8'hEB							
PAD_Y							

Mixer Output Split Line: Luminance(Y) value, default white color

Address= 8'hD7

Split Line CB							
7-bit	6-bit	5-bit	4-bit	3-bit	2-bit	1-bit	0-bit
8'h80							
PAD_CB							

Mixer Output Split Line: Chrominance (Cb) value, default white color

Address= 8'hD8

Split Line CR							
7-bit	6-bit	5-bit	4-bit	3-bit	2-bit	1-bit	0-bit
8'h80							
PAD_CR							

Mixer Output Split Line: Chrominance (Cr) value, default white color

Mixer OUTSEL Configuration Table

SEL	Type	NTSC 720	PAL 720	NTSC 960	PAL 960
SD Mode					
0	0	w c0 a3 02	w c0 a3 02	w c0 a3 03	w c0 a3 03
	1	w c0 a4 02	w c0 a4 02	w c0 a4 03	w c0 a4 03
	2	w c0 a5 d0	w c0 a5 d0	w c0 a5 c0	w c0 a5 c0
	3	w c0 a6 0f	w c0 a6 0f	w c0 a6 0f	w c0 a6 0f
	w c0 a7 10	w c0 a7 10	w c0 a7 10	w c0 a7 10	
	w c0 a8 00	w c0 a8 00	w c0 a8 00	w c0 a8 00	
	w c0 a9 00	w c0 a9 00	w c0 a9 00	w c0 a9 00	
	w c0 aa 68	w c0 aa 68	w c0 aa E0	w c0 aa E0	
	w c0 ab 00	w c0 ab 00	w c0 ab 00	w c0 ab 00	
	w c0 ac 10	w c0 ac 54	w c0 ac 10	w c0 ac 54	
	w c0 ad 00	w c0 ad 00	w c0 ad 00	w c0 ad 00	
	w c0 ae F0	w c0 ae 20	w c0 ae F0	w c0 ae 20	
	w c0 af 68	w c0 af 68	w c0 af E0	w c0 af E0	
	w c0 b0 F0	w c0 b0 20	w c0 b0 F0	w c0 b0 20	
	w c0 b1 12	w c0 b1 22	w c0 b1 13	w c0 b1 23	
	w c0 b2 D0	w c0 b2 D0	w c0 b2 C0	w c0 b2 C0	
w c0 b3 E0	w c0 b3 40	w c0 b3 E0	w c0 b3 40		

1	0		w c0 a3 02	w c0 a3 02	w c0 a3 03	w c0 a3 03	
			w c0 a4 02	w c0 a4 02	w c0 a4 03	w c0 a4 03	
	1		w c0 a5 d0	w c0 a5 d0	w c0 a5 c0	w c0 a5 c0	
			w c0 a6 03	w c0 a6 03	w c0 a6 03	w c0 a6 03	
			w c0 a7 00	w c0 a7 40	w c0 a7 00	w c0 a7 40	
			w c0 a8 00	w c0 a8 00	w c0 a8 00	w c0 a8 00	
			w c0 a9 00	w c0 a9 00	w c0 a9 00	w c0 a9 00	
			w c0 aa 00	w c0 aa 00	w c0 aa 00	w c0 aa 00	
			w c0 ab F0	w c0 ab 20	w c0 ab F0	w c0 ab 20	
			w c0 b1 12	w c0 b1 22	w c0 b1 13	w c0 b1 23	
			w c0 b2 D0	w c0 b2 D0	w c0 b2 C0	w c0 b2 C0	
			w c0 b3 E0	w c0 b3 40	w c0 b3 E0	w c0 b3 40	
	2	0		w c0 a3 02	w c0 a3 02	w c0 a3 03	w c0 a3 03
				w c0 a4 02	w c0 a4 02	w c0 a4 03	w c0 a4 03
1		w c0 a5 d0	w c0 a5 d0	w c0 a5 c0	w c0 a5 c0		
2		w c0 a6 07	w c0 a6 07	w c0 a6 07	w c0 a6 07		
		w c0 a7 00	w c0 a7 40	w c0 a3 03	w c0 a3 03		
		w c0 a8 00	w c0 a8 00	w c0 a4 03	w c0 a4 03		
		w c0 a9 00	w c0 a9 00	w c0 a5 c0	w c0 a5 c0		
		w c0 aa 00	w c0 aa 00	w c0 a7 00	w c0 a7 40		
		w c0 ab F0	w c0 ab 20	w c0 a8 00	w c0 a8 00		
		w c0 ac 01	w c0 ac 05	w c0 a9 00	w c0 a9 00		
		w c0 ad 68	w c0 ad 68	w c0 aa 00	w c0 aa 00		
		w c0 ae F0	w c0 ae 20	w c0 ab F0	w c0 ab 20		
		w c0 b1 12	w c0 b1 22	w c0 ac 01	w c0 ac 05		
		w c0 b2 D0	w c0 b2 D0	w c0 ad E0	w c0 ad E0		
		w c0 b3 E0	w c0 b3 40	w c0 ae F0	w c0 ae 20		
				w c0 b1 13	w c0 b1 23		
				w c0 b2 C0	w c0 b2 C0		
				w c0 b3 E0	w c0 b3 40		

3	<table border="1"> <tr> <td></td> <td>0</td> <td></td> </tr> <tr> <td>1</td> <td></td> <td>3</td> </tr> <tr> <td></td> <td>2</td> <td></td> </tr> </table>		0		1		3		2		w c0 a3 02	w c0 a3 02	w c0 a3 03	w c0 a3 03
			0											
		1		3										
			2											
		w c0 a4 02	w c0 a4 02	w c0 a4 03	w c0 a4 03									
		w c0 a5 d0	w c0 a5 d0	w c0 a5 c0	w c0 a5 c0									
		w c0 a6 0f	w c0 a6 0f	w c0 a6 0f	w c0 a6 0f									
		w c0 a7 00	w c0 a7 00	w c0 a7 00	w c0 a7 00									
		w c0 a8 B4	w c0 a8 B4	w c0 a8 F0	w c0 a8 F0									
		w c0 a9 00	w c0 a9 00	w c0 a9 00	w c0 a9 00									
		w c0 aa 00	w c0 aa 00	w c0 aa 00	w c0 aa 00									
		w c0 ab 00	w c0 ab 00	w c0 ab 00	w c0 ab 00									
		w c0 ac 20	w c0 ac 24	w c0 ac 20	w c0 ac 24									
		w c0 ad B4	w c0 ad B4	w c0 ad F0	w c0 ad F0									
		w c0 ae F0	w c0 ae 20	w c0 ae F0	w c0 ae 20									
		w c0 af 1C	w c0 af 1C	w c0 af D0	w c0 af D0									
		w c0 b0 00	w c0 b0 00	w c0 b0 00	w c0 b0 00									
w c0 b1 12	w c0 b1 22	w c0 b1 13	w c0 b1 23											
w c0 b2 D0	w c0 b2 D0	w c0 b2 C0	w c0 b2 C0											
w c0 b3 E0	w c0 b3 40	w c0 b3 E0	w c0 b3 40											
4	<table border="1"> <tr> <td>0</td> </tr> </table>	0	w c0 a3 02	w c0 a3 02	w c0 a3 03	w c0 a3 03								
		0												
		w c0 a4 02	w c0 a4 02	w c0 a4 03	w c0 a4 03									
		w c0 a5 d0	w c0 a5 d0	w c0 a5 c0	w c0 a5 c0									
		w c0 a6 01	w c0 a6 01	w c0 a6 01	w c0 a6 01									
		w c0 a7 00	w c0 a7 00	w c0 a7 00	w c0 a7 00									
		w c0 a8 00	w c0 a8 00	w c0 a8 00	w c0 a8 00									
		w c0 a9 00	w c0 a9 00	w c0 a9 00	w c0 a9 00									
		w c0 b1 12	w c0 b1 22	w c0 b1 23	w c0 b1 13									
		w c0 b2 D0	w c0 b2 D0	w c0 b2 C0	w c0 b2 C0									
		w c0 b3 E0	w c0 b3 40	w c0 b3 40	w c0 b3 E0									

5	<table border="1"> <tr> <td>0</td> <td>1</td> </tr> </table>	0	1	w c0 a3 02	w c0 a3 02	w c0 a3 03	w c0 a3 03		
		0	1						
		w c0 a4 02	w c0 a4 02	w c0 a4 03	w c0 a4 03				
		w c0 a5 d0	w c0 a5 d0	w c0 a5 c0	w c0 a5 c0				
		w c0 a6 03	w c0 a6 03	w c0 a6 03	w c0 a6 03				
		w c0 a7 10	w c0 a7 10	w c0 a7 10	w c0 a7 10				
		w c0 a8 00	w c0 a8 00	w c0 a8 00	w c0 a8 00				
		w c0 a9 00	w c0 a9 00	w c0 a9 00	w c0 a9 00				
		w c0 aa 68	w c0 aa 68	w c0 aa E0	w c0 aa E0				
		w c0 ab 00	w c0 ab 00	w c0 ab 00	w c0 ab 00				
		w c0 b1 12	w c0 b1 22	w c0 b1 13	w c0 b1 23				
		w c0 b2 D0	w c0 b2 D0	w c0 b2 C0	w c0 b2 C0				
		w c0 b3 E0	w c0 b3 40	w c0 b3 E0	w c0 b3 40				
		HD Mode							
8	<table border="1"> <tr> <td>0</td> <td>1</td> </tr> <tr> <td>2</td> <td>3</td> </tr> </table>	0	1	2	3	w c0 a6 0f	w c0 a6 0f	w c0 a6 0f	w c0 a6 0f
		0	1						
		2	3						
		w c0 a7 20	w c0 a7 20	w c0 a7 30	w c0 a7 30				
		w c0 a8 00	w c0 a8 00	w c0 a8 00	w c0 a8 00				
		w c0 a9 00	w c0 a9 00	w c0 a9 00	w c0 a9 00				
		w c0 aa D0	w c0 aa D0	w c0 aa C0	w c0 aa C0				
		w c0 ab 00	w c0 ab 00	w c0 ab 00	w c0 ab 00				
		w c0 ac 64	w c0 ac A8	w c0 ac 74	w c0 ac B8				
		w c0 ad 00	w c0 ad 00	w c0 ad 00	w c0 ad 00				
		w c0 ae E0	w c0 ae 1C	w c0 ae E0	w c0 ae 1C				
		w c0 af D0	w c0 af D0	w c0 af C0	w c0 af C0				
		w c0 b0 E0	w c0 b0 1C	w c0 b0 E0	w c0 b0 1C				
		w c0 b1 35	w c0 b1 45	w c0 b1 37	w c0 b1 47				
w c0 b2 A0	w c0 b2 A0	w c0 b2 80	w c0 b2 80						
w c0 b3 C0	w c0 b3 38	w c0 b3 C0	w c0 b3 38						

8	0	1		w c0 a6 0f		w c0 a6 0f
				w c0 a7 20		w c0 a7 30
	2	3		w c0 a8 00		w c0 a8 00
	PAL EXT			w c0 a9 00		w c0 a9 00
				w c0 aa D0		w c0 aa C0
				w c0 ab 00		w c0 ab 00
				w c0 ac A8		w c0 ac B8
				w c0 ad 00		w c0 ad 00
				w c0 ae 40		w c0 ae 40
				w c0 af D0		w c0 af C0
				w c0 b0 40		w c0 b0 40
				w c0 b1 45		w c0 b1 47
				w c0 b2 A0		w c0 b2 80
				w c0 b3 80		w c0 b3 80

Electrical Specifications

Absolute Maximum Ratings Over Operating Free-Air Temperature Range

Supply voltage range: IOV _{DD} to DGND
DV _{DD} to DGND
PLL_AV _{DD} to PLL_AGND
CH1_AV _{DD} to CH1_AGND
Digital input voltage range, V _I to DGND
Input voltage range, XTAL1 to PLL_GND
Analog input voltage range A _I to CH1_AGND
Digital Output voltage range, V _O to DGND
Operating free-air temperature, T _A

Recommended Operating Conditions

		MIN	TYP	MAX	UNIT
IODV _{DD}	Digital I/O supply voltage	2.97	3.3	3.63	V
DV _{DD}	Digital supply voltage	1.62	1.8	1.98	V
PLL_AV _{DD}	Analog PLL supply voltage	1.62	1.8	1.98	V
CH1_AV _{DD}	Analog core supply voltage	1.7	1.8	1.9	V
V _{I(P-P)}	Analog input voltage (ac-coupling necessary)	0.25		1.0	V
V _{IH}	Digital input voltage high	2		5	V
V _{IL}	Digital input voltage low	-0.3		0.8	V
V _{IH_XTAL}	XTAL input voltage high	0.7 PLL_AV _{DD}			V
V _{IL_XTAL}	XTAL input voltage low		0.3 PLL_AV _{DD}		V
I _{OH}	High-level output current			2	mA
I _{OL}	Low-level output current			-2	mA
I _{OH_SCLK}	SCLK high-level output current			4	mA
I _{OL_SCLK}	SCLK low-level output current			-4	mA
T _A	Operating free-air temperature	-40		125	°C

Crystal Specifications

CRYSTAL SPECIFICATIONS	MIN	NOM	MAX	UNIT
Frequency		27.0/36.0		MHz
Frequency tolerance		±100		ppm

Electrical Characteristics

$V_{DD} = 1.8\text{ V}$, $PLL_AV_{DD} = 1.8\text{ V}$, $CH1_AV_{DD} = 1.8\text{ V}$, $IOV_{DD} = 3.3\text{ V}$

For minimum/maximum values: $T_A = 0^\circ\text{C}$ to 70°C , and for typical values: $T_A = 25^\circ\text{C}$ unless otherwise noted

DC Electrical Characteristics

PARAMETER	TEST CONDITIONS (see NOTE 1)	MIN	TYP	MAX	UNIT
$I_{DD(IO_D)}$ Digital I/O supply current	Color bar input		4.8		mA
$I_{DD(D)}$ Digital core supply current	Color bar input		50.7		mA
$I_{DD(PLL_A)}$ Analog PLL supply current	Color bar input		5.9		mA
$I_{DD(CH1_A)}$ Analog PLL supply current	Color bar input		26.1		mA
P_{TOT} Total power dissipation, normal mode	Color bar input		165	205	mW
P_{DOWN} Total power dissipation, power-down mode	Color bar input			5	mW
C_i Input capacitance	By design		8		pF

V_{OH}	Output voltage high	$I_{OH} = 2 \text{ mA}$	$0.8 I_{OV_{DD}}$	V
V_{OL}	Output voltage low	$I_{OL} = -2 \text{ mA}$	$0.2 I_{OV_{DD}}$	V
V_{OH_SCLK}	SCLK output voltage high	$I_{OH} = 4 \text{ mA}$	2.3	V
V_{OL_SCLK}	SCLK output voltage low	$I_{OL} = -2 \text{ mA}$	0.6	V
I_{IH}	High-level input current	$V_I = V_{IH}$	± 50	μA
I_{IL}	Low-level input current	$V_I = V_{IL}$	± 50	μA

NOTE 1: Measured with a load of 15 pf.

Analog Processing and A/D Converters

PARAMETER		TEST CONDITIONS	MIN	TYP	MAX	UNIT
Z_i	Input impedance, analog video inputs	By design	500			$k\Omega$
C_i	Input capacitance, analog video inputs	By design		10		pF
$V_{i(pp)}$	Input voltage range *	$C_{coupling} = 0.1 \mu\text{F}$	0.25		1	V
ΔG	Gain control range			12		dB
DNL	DC differential non-linearity	A/D only		± 2		LSB
INL	DC integral non-linearity	A/D only		± 3		LSB
Fr	Frequency response	6 MHz		-0.9	-3	dB
SNR	Signal-to-noise ratio	6 MHz, 1.0 Vp-		50		dB

		p		
NS	Noise spectrum	50% flat field	50	dB
DP	Differential phase		1.5	°
DG	Differential gain		0.5%	

* The 0.75-V maximum applies to the sync-chroma amplitude, not sync-white. The recommended termination resistors are 37.4 Ω.

Timing

Clocks, Video Data, Sync timing

Data Format : CCIR656 output					
PARAMETER	SYMBOL	MIN	TYP	MAX	UNIT
PIXCLK High pulse duration	t_{hw}	18.5			ns
PIXCLK Low pulse duration	t_{lw}	18.5			ns
CCIR656 data out setup time	t_{su}	18.5			ns
CCIR656 data out hold time	t_h	18.5			ns

Output:CCIR656

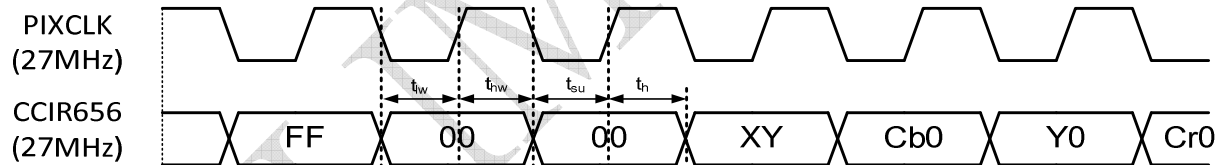
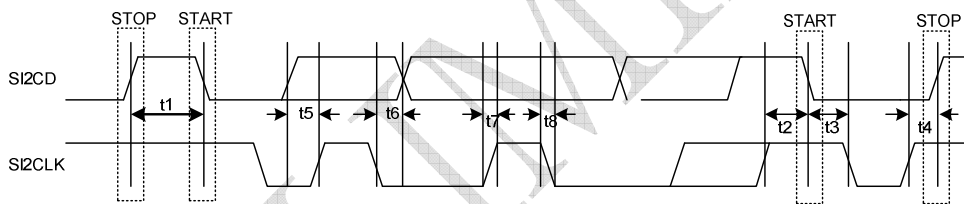

Figure 3-2 . Clocks, CCIR656 Output Data Timing

Data Format : CCIR656 input					
PARAMETER	SYMBOL	MIN	TYP	MAX	UNIT
PIXCLK High pulse duration	t_{hw}	18.5			ns
PIXCLK Low pulse duration	t_{lw}	18.5			ns
CCIR656 data out setup time	t_{su}	18.5			ns
CCIR656 data out hold time	t_h	18.5			ns

I²C Host Port Timing

PARAMETER	TEST CONDITIONS	MIN	TYP	MAX	UNIT
t₁ Bus free time between STOP and START		1.3			μs
t₂ Setup time for a (repeated) START condition		0.6			μs
t₃ Hold time (repeated) START condition		0.6			μs
t₄ Setup time for STOP condition		0.6			μs
t₅ Data setup time		200			ns
t₆ Data hold time		0		50	ns
t₇ Rise time I2CD and I2CLK signal		250			ns
t₈ Fall time I2CD and I2CLK signal			250		ns
C_b Capacitive load for each bus line				120	pF
f_{I2C} I ² C clock frequency				400	kHz



	Write Address	Read Address
SADD[0] Pull low SADD[1] Pull low	C0	C1
SADD[0] Pull high SADD[1] Pull low	C2	C3
SADD[0] Pull low SADD[1] Pull high	C4	C5
SADD[0] Pull high SADD[1] Pull high	C6	C7

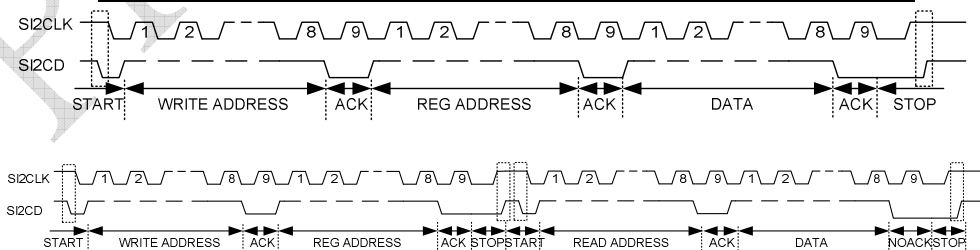

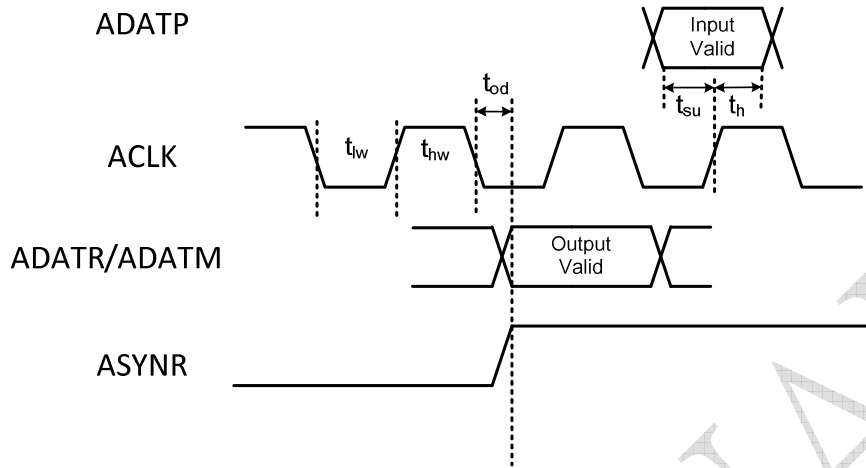
AC Characteristic of Digital Audio Interface

		Min	Typ	Max	Unit
t_{lw}	clock low time				ns
t_{hw}	clock high time				ns
t_{od}	output delay time				ns
t_{su}	input setup time				ns
t_h	input hold time				ns

Packaging

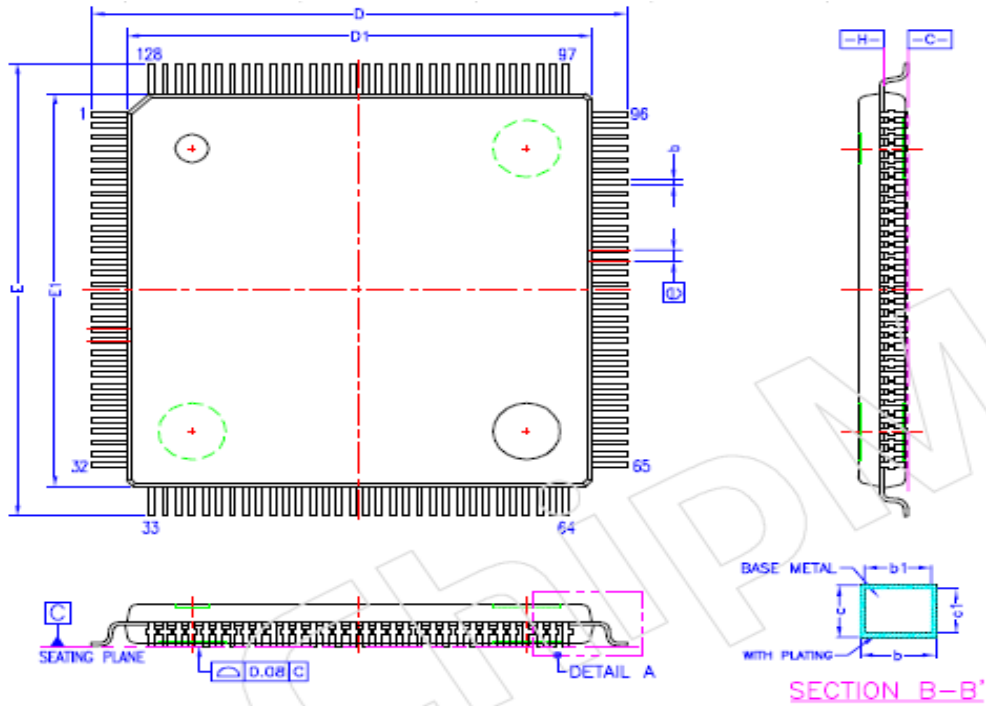

SYM.	DIMENSION (MM)			DIMENSION (INCH)		
	MIN	NOM	MAX	MIN	NOM	MAX
A	—	—	1.50	—	—	0.063
A1	0.05	0.10	0.15	0.002	0.004	0.006
A2	1.35	1.40	1.45	0.053	0.055	0.057
b	0.13	0.18	0.23	0.005	0.007	0.009
b1	0.13	0.16	0.19	0.005	0.006	0.007
c	0.09	—	0.20	0.004	—	0.008
c1	0.09	0.127	0.16	0.004	0.005	0.006
D	15.90	16.00	16.10	0.626	0.630	0.634
D1	13.90	14.00	14.10	0.547	0.551	0.555
E	15.90	16.00	16.10	0.626	0.630	0.634
E1	13.90	14.00	14.10	0.547	0.551	0.555
⌀	0.40 BSC			0.016 BSC		
L	0.45	0.60	0.75	0.018	0.024	0.030
L1	1.00 REF			0.040 REF		
R1	0.08	—	—	0.003	—	—
R2	0.08	—	0.20	0.003	—	0.008
⌀	⌀	3.5"	7"	⌀	3.5"	7"

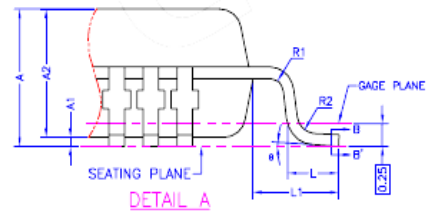

1. REFER TO JEDEC STD. MS-026
2. DIMENSION D AND E ARE DETERMINED AT SEATING PLANE $\square C \square$.
3. DIMENSION D1 AND E1 ARE DETERMINED AT DATUM $\square B \square$.
4. DIMENSION D1 AND E1 DO NOT INCLUDE MOLD PROTRUSION. ALLOWABLE PROTRUSION IS 0.25mm PER SIDE. D1 AND E1 ARE MAXIMUM PLASTIC BODY SIZE DIMENSIONS WHICH INCLUDE MOLD MISMATCH.
5. DIMENSION b DOES NOT INCLUDE DAMBAR PROTRUSION. ALLOWABLE DAMBAR PROTRUSION SHALL NOT CAUSE THE LEAD WIDTH TO EXCEED THE MAXIMUM b DIMENSION BY MORE THAN 0.08mm
6. ALL DIMENSIONS ARE IN MILLIMETERS.



DM5886

960H and 720H Decoder Mix 4 NTSC/PAL channels to a SD or HD

Ordering Information

Part Number	Pin Count	Package
DM5886EP	128	LQFP (Pb-Free and Halogen-Free)

Disclaimer

The information appearing in this publication is believed to be accurate. Integrated circuits sold by DAVICOM Semiconductor are covered by the warranty and patent indemnification provisions stipulated in the terms of sale only. DAVICOM makes no warranty, express, statutory, implied or by description regarding the information in this publication or regarding the information in this publication or regarding the freedom of the described chip(s) from patent infringement. FURTHER, DAVICOM MAKES NO WARRANTY OF MERCHANTABILITY OR FITNESS FOR ANY PURPOSE. DAVICOM reserves the right to halt production or alter the specifications and prices at any time without notice. Accordingly, the reader is cautioned to verify that the data sheets and other information in this publication are current before placing orders. Products described herein are intended for use in normal commercial applications. Applications involving unusual environmental or reliability requirements, e.g. military equipment or medical life support equipment, are specifically not recommended without additional processing by DAVICOM for such applications. Please note that

application circuits illustrated in this document are for reference purposes only.

DAVICOM's terms and conditions printed on the order acknowledgment govern all sales by DAVICOM. DAVICOM will not be bound by any terms inconsistent with these unless DAVICOM agrees otherwise in writing. Acceptance of the buyer's orders shall be based on these terms.

Company Overview

DAVICOM Semiconductor Inc. develops and manufactures integrated circuits for integration into data communication products. Our mission is to design and produce IC products that are the industry's best value for Data, Audio, Video, and Internet/Intranet applications. To achieve this goal, we have built an organization that is able to develop chipsets in response to the evolving technology requirements of our customers while still delivering products that meet their cost requirements.

Products

We offer only products that satisfy high performance requirements and which are compatible with major hardware and software standards. Our currently available and soon to be released products are based on our proprietary designs and deliver high quality, high performance chipsets that comply with modem communication standards and Ethernet networking standards.

Contact Windows

For additional information about DAVICOM products, contact the Sales department at:

Headquarters

Hsin-chu Office:

No.6 Li-Hsin Rd. VI,
Science-based Industrial Park,
Hsin-chu City, Taiwan, R.O.C.

TEL: +886-3-5798797

FAX: +886-3-5646929

MAIL: sales@davicom.com.tw

HTTP: <http://www.davicom.com.tw>

WARNING

Conditions beyond those listed for the absolute maximum may destroy or damage the products. In addition, conditions for sustained periods at near the limits of the operating ranges will stress and may temporarily (and permanently) affect and damage structure, performance and function.