

CLL Series

Photo-IC Sensors

Digital Output



March, 2003

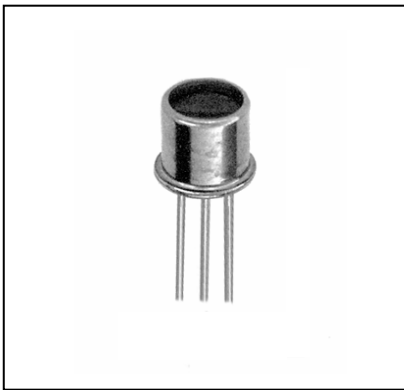

features

- Output stages:
 - a. Buffer or inverter
 - b. Open collector or internal 10KΩ pull-up
- Supply voltage 4.5V to 18V
- 7:1 user sensitivity adjustment on CLL130-CLL133 and CLL130W-CLL133W series
- Acceptance angle:
 - a. ± 15° high dome lens can
 - b. ± 35° flat window lens can
- Operates to 125°C
- RoHS compliant

description

The CLL series are monolithic integrated circuits incorporating a photodiode, linear amplifier, Schmitt trigger for hysteresis and pulse shaping, and digital output with either 10KΩ pull-up or open collector. The series includes TO-72 four lead packages (with user adjustable gain) and TO-18 three lead packages in both high dome and flat window configurations. Alternate pin-outs are available. Contact Clairex.

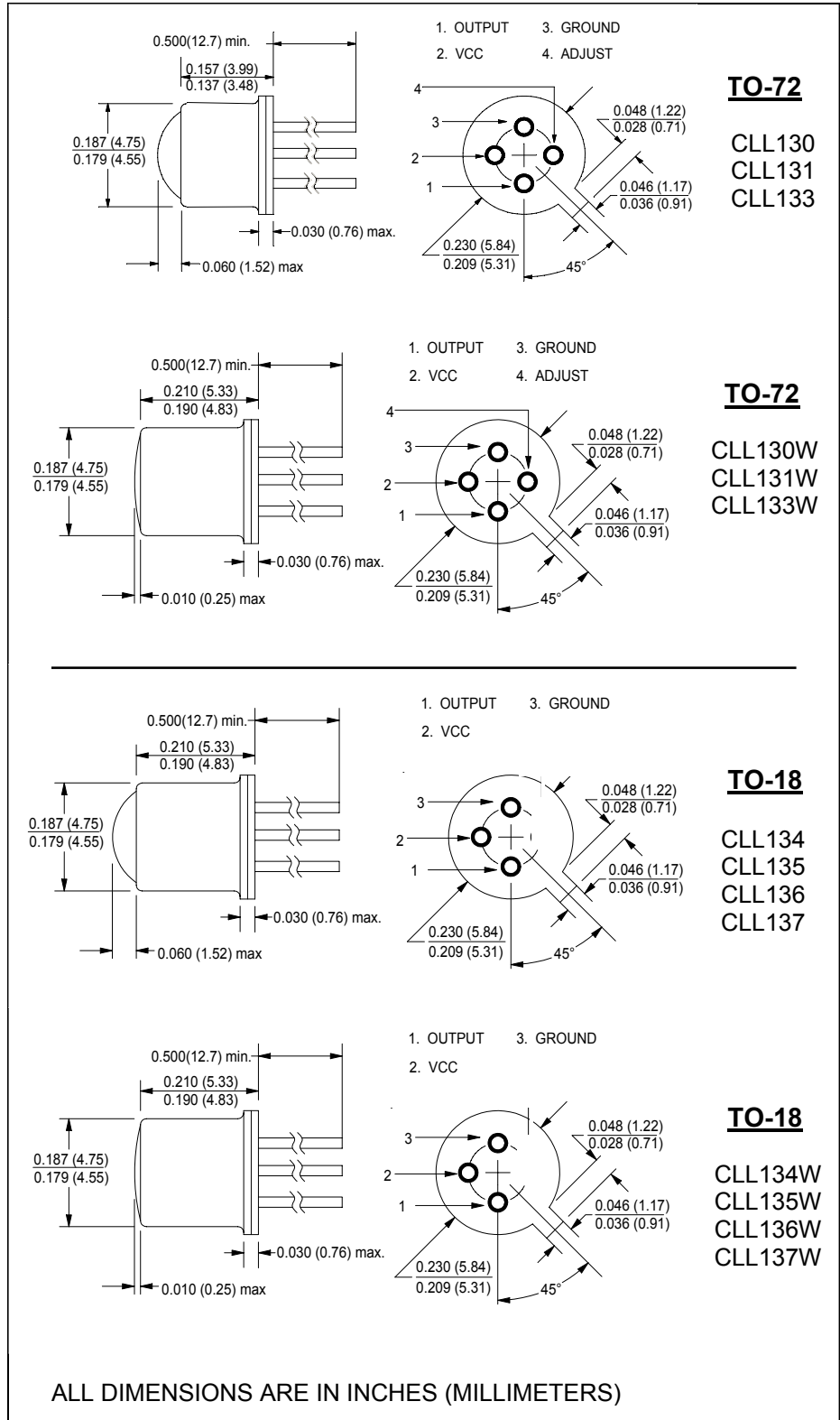

Revised 3/16/06

Clairex reserves the right to make changes at any time to improve design and to provide the best possible product.

Page 1 of 4

CLL Series

Photo-IC Sensors

Digital Output



Schematics

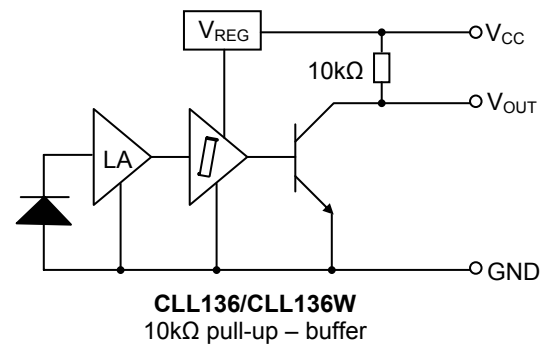
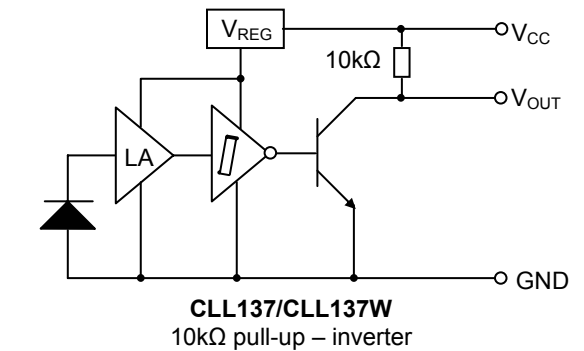
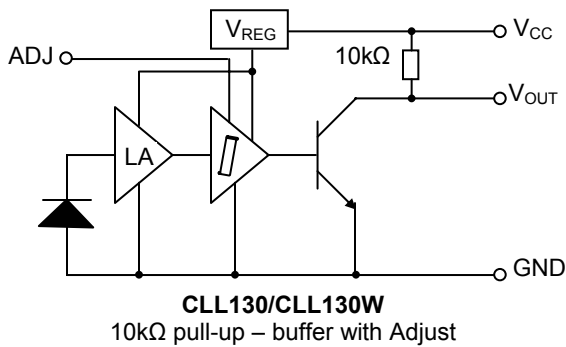
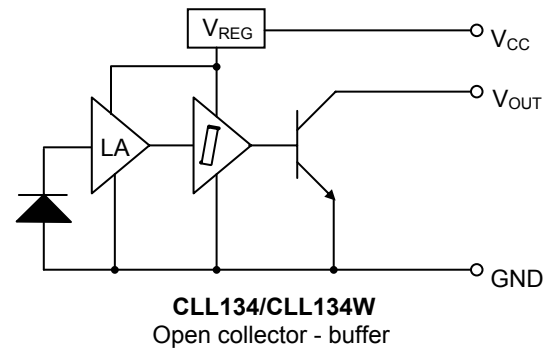
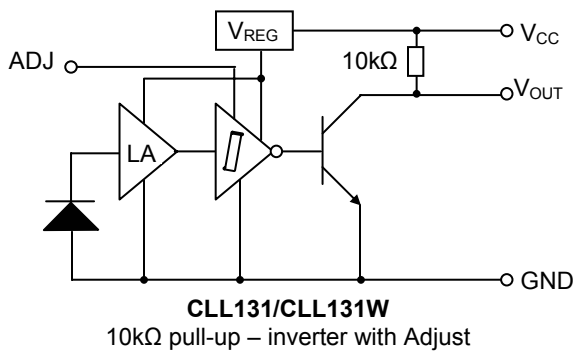
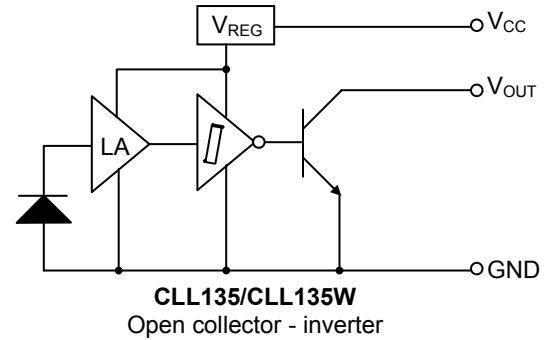
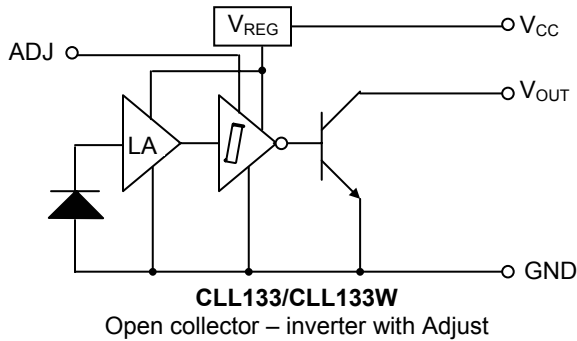

CLL Series

Photo-IC Sensors

Digital Output



Absolute maximum ratings ($T_A = 25^\circ\text{C}$ unless otherwise stated)

storage temperature	-65°C to +150°C
operating temperature	-65°C to +125°C
lead soldering temperature ⁽¹⁾	260°C
V_{CC} supply voltage	4.5V to 18V
V_{ADJ} (CLL130-CLL133 and CLL130W-CLL133W only)	3V
V_{OUT} (10k Ω pull-up series) ⁽²⁾	18V
V_{OUT} (open collector series) ⁽²⁾	30V
I_{SINK} ⁽³⁾	25mA
continuous power dissipation ⁽⁴⁾	250mW

NOTES:

- 1/16" from the case for 5 seconds maximum.
- This rating applies when the output is in the OFF state only.
- This rating applies when the output is in the ON state only.
- Derate linearly 2.0mW/°C from 25°C free air to $T_A = 125^\circ\text{C}$.
- CLL130-CLL133 and CLL130W-CLL133W photo-IC sensors are tested with the ADJ lead open.
- Light source is an AlGaAs IRED with peak wavelength at 850nm.

DEFINITIONS:

- $E_e (+)$ is the minimum irradiance required to cause the output to change state.
- Buffer: Output is HIGH when input irradiance is $>E_e (+)$.
- Inverter: Output is LOW when input irradiance is $>E_e (+)$.

electrical characteristics ($T_A = 25^\circ\text{C}$ unless otherwise noted)						
parameter	symbol	min	typ	max	units	test conditions
Operating supply voltage	V_{CC}	4.5	-	18	V	
Positive going threshold irradiance ⁽⁶⁾	$E_e (+)$	0.005	-	0.05	mW/cm ²	4.5V \leq V_{CC} \leq 18V, ADJ open, All non-suffix W parts. All suffix W parts.
		0.025	-	0.25	mW/cm ²	
Hysteresis ratio	$\frac{E_{eT} (+)}{E_{eT} (-)}$	1.1	-	1.8		operate point/release point
Supply current	I_{CC}	-	-	12	mA	4.5V \leq V_{CC} \leq 18V, $E_e = 0$ or 0.5mW, ADJ open
Total acceptance angle	Θ_P	-	30	-	deg.	All non-suffix W parts All suffix W parts
		-	70	-	deg.	

Gain threshold can be adjusted on the CLL130-CLL133 and CLL130W-CLL133W series by placing a resistor between the ADJ and GND leads in accordance with the following table. Decreasing the resistance causes the output to switch at a higher threshold level.

ADJ Resistor	Normalized Threshold
open	1.00
10k	2.00
4.7k	2.75
2.2k	3.75
1k	5.00
Connected to GND	7.25

CLL Series

Photo-IC Sensors

Digital Output



electrical characteristics ($T_A = 25^\circ\text{C}$ unless otherwise noted)						
parameter	symbol	min	typ	max	units	test conditions
CLL130/CLL130W and CLL136/CLL136W (buffer, 10k Ω pull-up)						
High state output voltage	V_{OH}	4.5	-	-	V	$V_{CC} = 5.0\text{V}$, $E_e (+) \geq 0.5\text{mW/cm}^2$
Low state output voltage	V_{OL}	-	-	0.4	V	$V_{CC} = 5.0\text{V}$, $E_e (+) = 0$
Output rise and fall time	t_r, t_f	-	75	-	ns	$V_{CC} = 5.0\text{V}$, $E_e = 0$ or 0.5mW/cm^2 , $f = 10\text{kHz}$, D.C. = 50%, $R_L = 330\Omega$
Propagation delay	t_{PHL}, t_{PLH}	-	5	-	μs	
CLL131/CLL131W and CLL137/CLL137W (inverter, 10k Ω pull-up)						
High state output voltage	V_{OH}	4.5	-	-	V	$V_{CC} = 5.0\text{V}$, $E_e (+) = 0$
Low state output voltage	V_{OL}	-	-	0.4	V	$V_{CC} = 5.0\text{V}$, $E_e (+) \geq 0.5\text{mW/cm}^2$
Output rise and fall time	t_r, t_f	-	75	-	ns	$V_{CC} = 5.0\text{V}$, $E_e = 0$ or 0.5mW/cm^2 , $f = 10\text{kHz}$, D.C. = 50%, $R_L = 330\Omega$
Propagation delay	t_{PHL}, t_{PLH}	-	5	-	μs	
CLL134/CLL134W (buffer, open collector)						
High state output current	I_{OH}	-	-	100	μA	$V_{CC} = 5.0\text{V}$, $V_{OH} = 30\text{V}$ $E_e (+) \geq 0.5\text{mW/cm}^2$
Low state output voltage	V_{OL}	-	-	0.4	V	$V_{CC} = 5.0\text{V}$, $E_e (+) = 0$ $R_L = 330\Omega$
Output rise and fall time	t_r, t_f	-	75	-	ns	$V_{CC} = 5.0\text{V}$, $E_e = 0$ or 0.5mW/cm^2 , $f = 10\text{kHz}$, D.C. = 50%, $R_L = 330\Omega$
Propagation delay	t_{PHL}, t_{PLH}	-	5	-	μs	
CLL133/CLL133W and CLL135/CLL135W (inverter, open collector)						
High state output current	I_{OH}	-	-	100	μA	$V_{CC} = 5.0\text{V}$, $V_{OH} = 30\text{V}$ $E_e (+) = 0$
Low state output voltage	V_{OL}	-	-	0.4	V	$V_{CC} = 5.0\text{V}$, $R_L = 330\Omega$ $E_e (+) \geq 0.5\text{mW/cm}^2$
Output rise and fall time	t_r, t_f	-	75	-	ns	$V_{CC} = 5.0\text{V}$, $E_e = 0$ or 0.5mW/cm^2 , $f = 10\text{kHz}$, D.C. = 50%, $R_L = 330\Omega$
Propagation delay	t_{PHL}, t_{PLH}	-	5	-	μs	

NOTE: Due to the high sensitivity of the CLL series, when used in high speed switching applications, Clairex recommends installing a 0.1 μF capacitor between V_{CC} and GND.