

# CLI305

## IRED - Phototransistor Photointerrupter

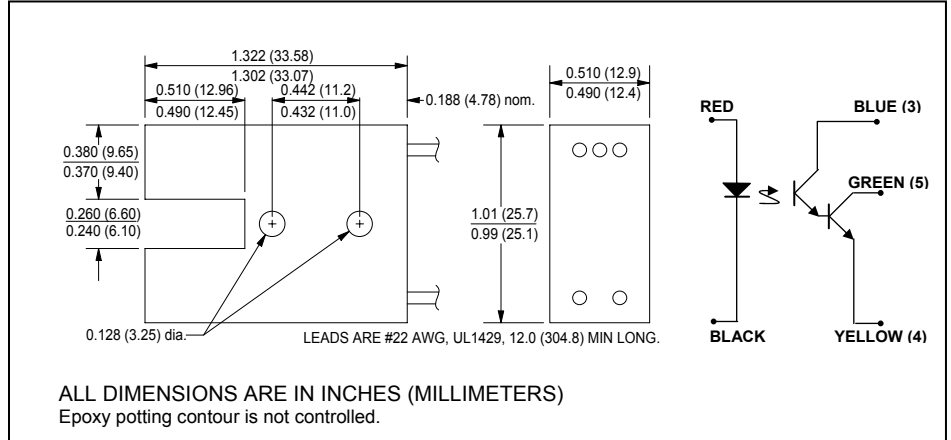

September, 2001



### features

- rugged plastic package
- hermetically sealed discretes
- narrow beam alignment

### description

The CLI305 consists of an IRED and a phototransistor mounted in a black plastic housing. It features 12 inch leads and two holes for bracket mounting in any position. Output is an emitter follower transistor providing high gain, fast switching speed and TTL interfacing. There is a 0.005" wide aperture in front of the phototransistor. For assistance, call Clairex.

### absolute maximum ratings ( $T_A = 25^\circ\text{C}$ unless otherwise stated)

|   |                 |
|---|-----------------|
| storage and operating temperature.....                    | -55°C to +100°C |
| LED   |                 |
| continuous forward DC current.....                        | 60mA            |
| reverse DC voltage.....                                   | 3V              |
| power dissipation <sup>(1)</sup> .....                    | 100mW           |
| OUTPUT TRANSISTOR   |                 |
| collector-emitter voltage.....                            | 30V             |
| maximum continuous collector current <sup>(2)</sup> ..... | 100mA           |
| power dissipation <sup>(3)</sup> .....                    | 200mW           |

### notes:

1. Derate linearly 1.07mW/°C from 25°C free air temperature to  $T_A = +100^\circ\text{C}$ .
2. 200mA when pulsed at 300µs, 2% duty cycle.
3. Derate linearly 2.13mW/°C from 25°C free air temperature to  $T_A = +100^\circ\text{C}$ .

| electrical characteristics ( $T_A = 25^\circ\text{C}$ unless otherwise noted) |  |     |     |      |       |   |
|---|--|-----|-----|------|-------|---|
| symbol  | parameter                                    | min | typ | max  | units | test conditions                           |
| <b>Input IRED</b>   |  |     |     |      |       |   |
| $V_F$   | Forward voltage                              | -   | -   | 1.5  | V     | $I_F = 16\text{mA}$                       |
| $I_R$   | Reverse current                              | -   | -   | 10   | µA    | $V_R = 3\text{V}$                         |
| <b>Output Transistor (leads 4 and 5)</b>                                      |  |     |     |      |       |   |
| $I_D$   | Collector-emitter dark current               | -   | -   | 100  | nA    | $V_{CE} = 10\text{V}, E_e = 0$            |
| <b>Coupled</b>  |  |     |     |      |       |   |
| $I_L$   | Sensor current (lead 4)                      | 20  | -   | -    | mA    | $I_F = 10\text{mA}, V_{CE} = 5\text{V}$   |
| $V_O$   | Voltage between leads 4 and 5 <sup>(4)</sup> | -   | -   | 0.50 | V     | $I_F = 20\text{mA}, V_{CE} = 5\text{V}$   |
| $V_{OFF}$   | Voltage between leads 4 and 5 <sup>(4)</sup> | 4.7 | -   | -    | V     | $E_e = 0$                                 |
| $t_r$   | Output rise time <sup>(4)</sup>              | -   | 5   | -    | µsec  | $I_C = 2.0\text{mA}, V_{CE} = 10\text{V}$ |
| $t_f$   | Output fall time <sup>(4)</sup>              | -   | 50  | -    | µsec  | $I_C = 2.0\text{mA}, V_{CE} = 10\text{V}$ |

note: 4. 2.2kΩ resistor between leads 3 and 5.

Clairex reserves the right to make changes at any time to improve design and to provide the best possible product.

Revised 10/01/04

Clairex Technologies, Inc.  
Phone: 972-265-4900

1301 East Plano Parkway  
Fax: 972-265-4949

Plano, Texas 75074-8524  
www.clairex.com