

CLE400F

Four leaded Multiple Emitter Chip Surface Mount Package

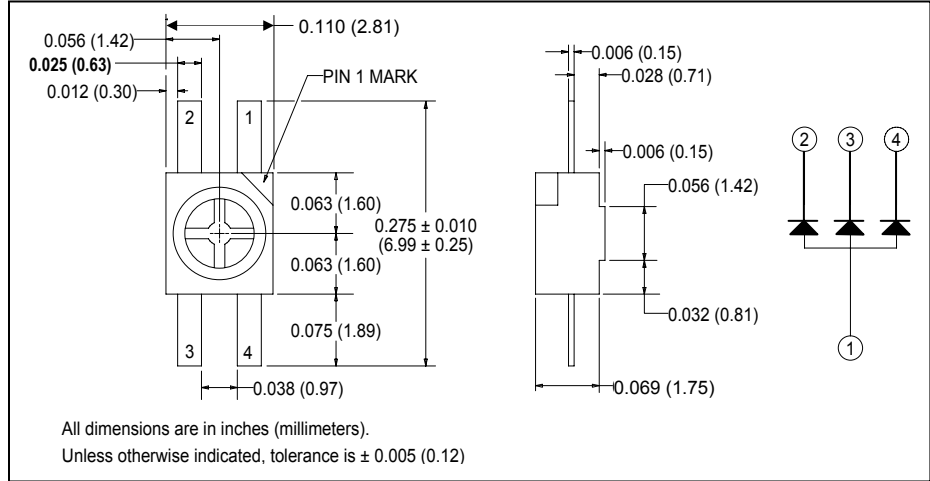

March, 2002



features

- $\pm 70^\circ$ emission angle
- wide variety of chip combinations
- wide variety of lenses and apertures

description

The CLE400F can contain three 850 nm IRED chips which feature double/double heterojunction (DDH) construction for increased quantum efficiency and reliability. This device is one example of a very broad line of devices made possible by four leaded package configuration. One to three chips can be attached. Multiple chip devices can be series or parallel connected. Wavelengths can range from ultra-violet (390nm) through the visible spectrum into the near infrared (940nm). Also different lenses, apertures and lead configurations are available. The standard lensing is clear epoxy.

absolute maximum ratings ($T_A = 25^\circ\text{C}$ unless otherwise stated)

storage temperature	-40°C to +100°C
operating temperature	-40°C to +100°C
lead soldering temperature ⁽¹⁾	260°C
continuous forward current ⁽²⁾	20mA/per chip
peak forward current (1.0ms pulse width, 10% duty cycle)	1A
reverse voltage	5V
continuous power dissipation ⁽³⁾	80mW

notes:

1. For 5 seconds maximum
2. Derate linearly 0.213mA/°C from 25°C free air temperature to $T_A = +100^\circ\text{C}$.
3. Derate linearly 0.85mW/°C from 25°C free air temperature to $T_A = +100^\circ\text{C}$.

electrical characteristics ($T_A = 25^\circ\text{C}$ unless otherwise noted)

symbol	parameter	min	typ	max	units	test conditions
P_O	Total power output ⁽⁴⁾	9.0	13.0	-	mW	$I_F = 60\text{mA}$ (total cathode current)
V_F	Forward voltage	-	-	1.4	V	$I_F = 20\text{mA}$ per chip
I_R	Reverse current	-	-	10	μA	$V_R = 5\text{V}$
λ_p	Peak wavelength emission	-	850	-	nm	$I_F = 20\text{mA}$
BW	Spectral bandwidth at half power points	-	60	-	nm	$I_F = 20\text{mA}$
θ_{HP}	Emission angle at half power points	-	140	-	deg.	$I_F = 20\text{mA}$

note: 4. Power output is measured in an integrating sphere.

Clairex reserves the right to make changes at any time to improve design and to provide the best possible product.

Revised 4/17/07

Clairex Technologies, Inc.
Phone: 972-265-4900

1301 East Plano Parkway
Fax: 972-265-4949

Plano, Texas 75074-8524
www.clairex.com